

Performance Evaluation and Design of RO Desalination Plant: Case Study

Mona A. Abdel-Fatah^{1*}, Ayman El-Gendi¹, Fatma Ashour²

¹Department of Chemical Engineering & Pilot Plant, National Research Center, Giza, Egypt

²Department of Chemical Engineering, Faculty of Engineering, Cairo University, Giza, Egypt

Email: *monamamin7@yahoo.com

Received 2 January 2016; accepted 14 February 2016; published 17 February 2016

Copyright © 2016 by authors and Scientific Research Publishing Inc.

This work is licensed under the Creative Commons Attribution International License (CC BY).

<http://creativecommons.org/licenses/by/4.0/>



Open Access

Abstract

The aim of this paper is to design a water desalination plant using Reverse Osmosis membrane to treat salt water to be usable for drinkable, domestic, industrial or agricultural uses. RO unit is designed to conservative standards for versatility in the event of feed water quality variations. The design includes a feed water flush cycle to minimize membrane fouling and piping corrosion during shutdown. The system will be all appropriate controls and instrumentation for automatic operation. All system components are available and of heavy duty industrial design and fabricated with the highest quality workmanship. Quality control will be maintained throughout all manufacturing processes. The system will produce permeate water minimum of 3600 m³/day with a quality of approximately 100 ppm total dissolved solids (TDS) when operating on well feed water with a 10,000 ppm TDS and a temperature of 25 - 30 degrees C. The design permeate recovery is 50%; and energy recovery device which saves \$30,556.28/year.

Keywords

Desalination, Brackish Water, RO Design Unit, Energy Recovery Systems

1. Introduction

Worldwide populace development and related examples of utilization are putting expanding weight upon assets, especially freshwater [1]-[3]. The low percentages of fresh water (about 2.5% of water is fresh) and the terrible utilization of it may lead us to a fresh water shortage catastrophe. In spite of the fact that entrance to safe drinking water has expanded in the most recent decades, around one billion persons still need access to safe water. Some researchers verbalized that by 2025 more than a moiety of the world will face water-predicated suscepti-

*Corresponding author.

bility [3]-[5]. Thus, water treatment is becoming an important solution for overcoming the shortage of drinking water. Water treatment processes are the removal of contaminants from untreated water to produce pure water for human utilization [6] [7]. Substances that are evacuated amid the procedure of drinking water treatment can be classified into three classifications [7] [8]: Suspended solids, Dissolved matter and Biological matter. The contaminants of water for the most part originate from nature, from the treatment process itself or from the transportation technique. Contaminants may be Mineral Pollutants, Organic Pollutants, Biological Pollutants, Suspended solids, Dissolved matter and Biological organisms [6]-[9]. Also of the WHO rules, every nation or domain can have their own particular rules. Thus, there is developing enthusiasm for systems to upgrade the accessibility of freshwater. In waterfront areas, desalination of saline water is progressively investigated and used as a strategy to supplement different wellsprings of water supply [10]-[13]. There are three major techniques for desalination [14]: thermal desalination (involves phase change); membrane desalination (Reverse Osmosis, Forward Osmosis, and Membrane Distillation) and ion exchange desalination [15]-[20]. Water desalination by the system of reverse osmosis has turned out to be the most reduced vitality expending strategy concurring to numerous studies [17]-[22]. It expends almost around a half portion of the vitality required for thermal processes. Additionally, the particularity of reverse osmosis units, their straight for wardens of operation, and their reduced sizes also, lower ecological effects give them need to be utilized for water desalination in remote regions. Water desalination by reverse osmosis units evacuates inorganic particles as well as natural matters, infections and microorganisms [5] [22]. Water desalination via membrane may be the most important process for any country to just stay alive even without urbanization. This fact was our driving force to choose water desalination as our case study.

The aim of this work is to design a water desalination plant using Reverse Osmosis membrane to treat ground water to be usable for domestic, industrial or agricultural uses. This work can be applicable anywhere near a source of water and can solve the problem of water in the deserts of Egypt. The treatment includes removal of suspended solids by coagulation and flocculation, settling and clarification and filtration; also removal of dissolved matters by ion exchange, thermal processes or membranes. The treatment also includes the removal of biological matters by disinfection. The most essential part which the focus is upon is water desalination by membranes, the reverse osmosis theory, types of membranes, feed water specifications for the membranes and the conditions that the membranes work it. The work covers not only the designing of the plant, but also the plant operation, maintenance, quality control and cost of control.

2. Experiment

2.1. Feed Raw Water Characteristics

Feed water quality has a significant impact on the design of the RO membrane system. Selection of the design flux, feed water and reject flows, and salt rejection is influenced by the feed water quality. Total dissolved solids (TDS), total suspended solid (TSS) and chemical oxygen demand (COD) were also measured. The aim from TDS test is to determine the TDS in the feed water so that we can calculate number of membrane elements and the pressure of the high pressure pump needed to reach the desalinate the water. Determination of TSS in feed water which we have to remove in pretreatment before introducing water to the membranes. Measuring of COD in the feed raw water was to know if there's a need for coagulation or no. **Table 1** represents the characteristics of feed raw water.

2.2. General Description of the RO Plant

The plant has been designed to produce permeate minimum of 3600 m³/day of potable water from a brackish water. The total dissolved solid (TDS) of product water is designed to be less than 100 ppm. The plant comprises of a desalination unit, raw water transit, filter backwash, and water transit, tanks with net volume 50 m³/100m³, draw back tank with net volume of 8.7 m³, membrane cleaning unit (CIP), PLC control unit and motor control centre.

2.3. Design Conditions

The RO desalination plant has been designed according to the conditions to satisfy the plant capacity with a min. capacity 3600 m³/day. The raw water coming from brackish contains 4850 - 7198 mg/l total dissolved solids, predominantly chloride and Na ions. Manganese concentrations are almost constant.

The feed water temperature is in range 10°C - 40°C. Raw water analysis is presented in **Table 1**. According to the World Health Organization, the specifications of potable water produced from desalination unit must be as shown in **Table 2**.

2.4. Case Study

2.4.1. Reverse Osmosis System

Proposes to submit an exceptional RO design to provide 3600 m³/day design on three years projection based on feed water with 50% design permeate recovery rate. The system will produce permeate water with a quality of approximately 100 ppm TDS when operating on well feed water with a TDS of 10,000 ppm and a temperature of 25°C - 30°C. The system feed water requirements are 7200 m³/day and 5 bars during normal operation. System Process for a Permeate of capacity 3600 m³/day (High Brackish Water) are consists of: Raw water pump provide the pressure to sand/carbon filter, sand filter—get rid of turbidity, suspended matter, organic matter, colloid etc., carbon filter odor, free chloride, organic matter, harmful matter and so on, prefilter prevent any deposition of large particles, some bacteria, and viruses into the RO membrane. The accuracy is 5 µm, for holding back any large particulates such as large iron, dust, suspended matter, impurity, and high pressure pump provide the high pressure to RO membrane, at least 1.0 Mpa and RO system which is the heart part of pure water plant. The RO systems are capable of removing over 99% of ions, bacteria's, particles and 98% of organics and silica, 85% of Boron.

Table 1. Characterization of brackish water (the plant feed).

Name	Adjusted Feed	Concentrate	Permeate
K	456.0	905.48	6.62
Na	1605	3189	21.35
Mg	165.0	329.23	0.81
Ca	369.0	736.31	1.77
CO ₃	0.06	0.33	0.00
HCO ₃	208.14	412.54	4.74
Cl	2415.99	4798.72	33.76
SO ₄	2011.34	4011.28	11.81
CO ₂	172.8	172.95	171.8
TDS	7230.57	14382.93	80.85
pH	6.00	6.21	4.62

^aThe temperature of water feed is in range 10°C - 40°C, all units by mg/l or ppm except pH.

Table 2. Guide for potable water (all units by mg/l or ppm except pH).

Constituent	Limits maximum (ppm)
TDS	500
Cl	250
Mg	30
Ca	75
SO ₄	200
NO ₃	10
NO ₂	10
F	0.1
Fe	0.1
Mn	0.05
pH	7 - 8.5

2.4.2. General Feature Overview

- The system will produce 3600 m³/day at 10,000 ppm TDS.
- 132 (22 × 6) Film Tec. membranes element will be utilized in one stage design.
- 316-St.St high pressure pump will be utilized. The system is equipped with all necessary instrumentation such as; temperature gauge, conductivity meter, flow meters and pressure gauges.
- No. (5) Chemical dosing systems complete with all accessories will be supplied, based on the final water analysis quantity and type of chemicals will be determined.

2.4.3. The Plant Process Train

RO units are designed to conservative standards for versatility in the event of feed water quality variations. The design includes a feed water flush cycle to minimize membrane fouling and piping corrosion during shutdown. The system will be all appropriate controls and instrumentation for automatic operation. All system components are be of heavy duty industrial design and fabricated with the highest quality workmanship and components available. Quality control will be maintained throughout all manufacturing processes.

Feed water for the system will be supplied via well water. A supply pump will provide the RO unit with appropriate flow and pressure. The next step in the process is multimedia filtration (sand and activated carbon) where suspended particles 20 microns and larger will be removed. The feed water is then injected with an anti-scalant which will inhibit membrane fouling due to mineral and colloidal precipitation. The feed water is then filtered via a five micron rated cartridge filters. The treated feed water then enters the suction of the high pressure booster pump for delivery to the RO membrane assemblies. The feed water is then split into two streams, permeate and the concentrate. The RO permeate will be injected with disinfecting and pH adjusting chemicals where it then flows to a holding tank of use. The concentrate stream is directed to the disposal methods as determined by local practices.

2.4.4. Sequence of Operation

The operation sequence is suggested to be as follows:

1) Level controls, located in the owner's product storage tank, will send a control signal to the control panel to begin the start sequence. The supply pump will then be energized to supply feed water to the RO unit. The feed water chemical injection system will then be activated.

2) As water pressure builds in the RO membrane feed pump suction line, a pressure switch senses the line pressure of the water entering the pump. This switch activates a timer which delays further start sequences until all water lines and pressure vessels reach normal start-up pressures. At the end of the time delay, a start control signal is sent to the RO membrane feed pump starter. The RO membrane feed pump then starts and supplies the necessary feed water pressure to the membrane array. The optional post treatment chemical feeds are started at this time.

3) The RO permeate flows to the product water storage tank. When the storage tank is full the level switch sends the shutdown signal to the RO control panel and the system then begins its post-flush cycle which removes all concentrated contaminants from the system. Once complete, the system waits for the next start signal.

2.5. Equipment Specification

2.5.1. Major Equipments

1) Chemical Feed Systems

- Acid, anti-foulant, disinfection and caustic for systems are complete with:
- 60 - 100 L polyethylene solution tank, with mixer.
- Positive displacement pumps with stroke and speed adjustment, level switch.
- Fittings and tubing. These systems will be activated automatically by the RO control panel. Level switches are provided to shut the system down in the event of low chemical levels in the day tanks.

2) Cartridge Filters

One filter unit, the unit houses are 2 (54*30"); model 162EFCF3-6FC100, 5 micron XL1 Wound Cartridge Filter. The housing is in FRP material of construction. Isolation valves are provided to facilitate servicing of the units.

3) RO Pump

One centrifugal multistage 316 St. St stainless steel pump shall be used. The motor is a TEFC 380 V, 50 Hz, 300 HP design. Minimum system supply pressure is 3.7 bars.

4) Reverse Osmosis Membranes

Thin-film composite, spiral wound membranes are the optimum for this application. 8" diameter × 40" long low energy Filmtec elements provided within twenty two (22) FRP pressure vessels. The membrane flux rate is very conservative. The vessels have a working pressure rating of 450 PSIG at 150°F. These spiral wound membranes are less susceptible to fouling from colloidal and scale solids and are much easier to clean than the hollow-fiber types. The materials of construction are not subject to bacterial attack or hydrolysis at high or low pH. Thin-film composite membrane offers higher productivity and less compaction, as well as better salt rejection with lower applied pressure; process flow diagram shown in **Figure 1**.

5) Permeate Flush/Cleaning System

One system will be provided. This system consists of: (1) 1000 gal polyethylene tank; (1) centrifugal pump, 316 St. St construction with a 20 HP, 380 V, 50 HZ, 3 phase, TEFC motor; (1) lot manual PVC butterfly/ball valves; (1) lot PVC such 80 piping; (1) tank level switch; (1) pressure gauge; (1) temperature gage; (4) cleaning hoses, two FRP cartridge filters. The system will flush the brackish water and concentrate from the RO unit at every shut down thus minimizing corrosion on the metallic components in the system and prolonging the life of the RO membranes. This system doubles as the membrane cleaning system.

6) System Instrument, Control and Power Panel

One (1) central RO Control Panel is provided. The panel will house all system related controls, instrumentation and across the line type pump starters. The central RO Control panel enclosure is NEMA 4 rated. Local conduit and electrical components are also NEMA 4× rated. The controls are PLC based. Indicating lights are provided for all alarm functions. Main power is 380 V, 3 Phase, 50 HZ. Control power is 220 V, 1 Phase, 50 HZ.

2.5.2. Component Specifications**1) Piping**

All welded high pressure piping is 316 stainless steel and Zeron 100. The low pressure piping is PVC such 80. The arrangement of the piping and valves has been developed for ease of service and operation.

2) Valves

High pressure valves are 316 stainless steel construction and Zeron 100. Low pressure valves are PVC construction. Ball valves, butterfly valves, wafer and Y type check valves are used.

3) Pressure Gauges

Pressure gauges are constructed of 316 SS and are glycerin filled, 4.5" dial.

4) Flow Indicators

Digital type flow meters shall be used to indicate the flow of the reject and product streams in order to monitor unit operations. These are mounted for viewing convenience.

5) Conductivity Meter and pH Meter

Digital type conductivity and ph monitors shall be used to indicate the quality of the product and feed water in order to monitor unit operations. This meter is panel mounted.

6) Structural Fabrication

The RO system skid and structural support members are constructed of Aluminum. The skid is painted with two coats of acrylic industrial primer and two coats of high performance acrylic industrial enamel.

2.5.3. Safety Devices

Process monitoring devices are provided to prevent the damage of components due to process upsets. Alarm conditions will be indicated via panel mounted lights:

- 1) The chemical feed systems include solution tank low level switches. Low chemical levels will shut down the RO system.
- 2) The RO pump is protected from low suction conditions by a pressure switch located on the suction side of the pump.
- 3) The RO pump and membranes are protected from high discharge pressure by a pressure switch.
- 4) A power monitor is included to protect against variations in incoming voltage or phase loss.

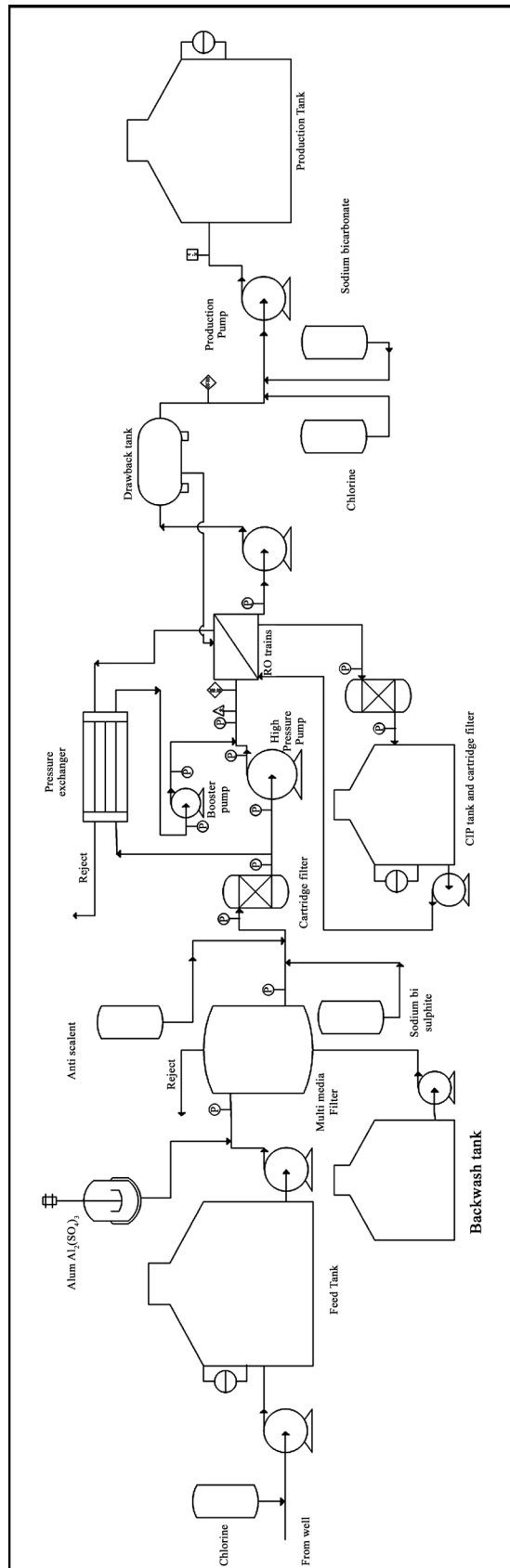

Figure 1. Process flow diagram for RO Unit.

- 5) The RO motor is protected by an overload relay.
- 6) Membranes are protected from free chlorine by shutdown alarm relay found in the ORP.

2.5.4. Automation

The following automatic features are provided for on this system.

- 1) System start and stop can be manual or automatic.
- 2) All auxiliary process equipment will be automatically switched “on” with plant start-up. All safety devices as previously described are operable in the automatic mode.
- 3) All automatic shutdowns are indicated after shutdown.

The RO membrane cleaning unit (CIP) system is used to prepare and recirculation chemical cleaning solutions independently through each stage of the RO membrane trains. The CIP system is manually initiated, and is operated from local controls adjacent to the CIP pump and tank. Cleaning chemicals are manually loaded to the CIP tank through a top hatch for batching of dry fed chemicals directly to the tank. Alternately, bulk liquid cleaning chemical deliveries can be pumped into the tank. Dry chemicals are diluted and mixed with RO permeate. The CIP pump draws from the CIP tank and is capable of circulating the solution to either the RO train or back to the CIP tank to mix the contents. The cleaning tank is fitted with one flanged immersion heater to achieve the required temperature of the cleaning solution. Piping connections at each RO train allow for each membrane stage to be cleaned independently. Reverse Osmosis System, Piping and valve at the CIP tank is provided to allow the cleaning solution to be re-circulated back to the tank, or discharged to the sewer for disposal. A utility water service connection is provided to allow use of potable water for preparation of the cleaning solution, when RO permeate is not available. **Table 3** represents typical cleaning characteristics.

3. Results and Discussion

3.1. Desalination Unit Design

In this work reverse osmosis system has been used to desalinate brackish water to get potable water. The process includes pre-treatment, desalination by reverse osmosis membranes and post treatment. According to the specifications of the required plant, wanted permeate flow rate is 3600 m³/day.

3.2. Design of Major Items

3.2.1. Feed Pump

$$Re = \frac{\rho v^2 D}{\mu}$$

$$\text{Feed Flow rate} = 7200 \text{ m}^3/\text{day}$$

$$D = 12''$$

$$V = 1.17 \text{ m/s}$$

Table 3. Typical cleaning characteristics.

Parameter	Value
Temperature, °C	40
pH	2 to 11.5
Specific Gravity	1.00 to 1.05
Concentration of Chemical (%)	0.5 to 2.0
Typical Chemicals Used	Citric Acid Sodium Hydroxide Tetra-sodium EDTA Sodium Tri-polyphosphate Sodium Dodecyl-benze-Sulfonate
Cleaning Solution Flow, gpm per vessel	40

$$Re = \frac{\rho v^2 D}{\mu} = \frac{1010 \times 1.17^2 \times 0.304}{10^{-3}} = 420307$$

Applying Bernoulli equation between feed tank and after feed pump:

$$\frac{P_1}{\rho g} + Z_1 + \frac{V_1^2}{2g} + h_p = \frac{P_2}{\rho g} + Z_2 + \frac{V_2^2}{2g} + h_l$$

$$1 + 12.6 + 0 + h_p = 43 + 1 + \frac{1.6^2}{2 \times 9.81} + h_l$$

$$h_l = h_{\text{valves}} + h_{\text{elbows}} + h_{\text{sudden contraction}} + h_{\text{pipes}}$$

$$h_{\text{valve (gate)}} = \frac{KV^2}{2g} = 0.17 \times \frac{1.17^2}{2 \times 9.81} = 0.01 \text{ m}$$

$$h_{\text{elbows}} = 4 \times 0.75 \times \frac{1.17^2}{2 \times 9.81} = 0.2 \text{ m}$$

$$h_{\text{sudden contraction}} = 0.55 \times \frac{1.17^2}{2 \times 9.81} = 0.038 \text{ m}$$

$$h_{\text{pipes}} = \frac{4flv^2}{2D} = \frac{2 \times 0.024 \times 12 \times 1.17^2}{0.304} = 2.59 \text{ m}$$

$$h_l = 2.853 \text{ m}$$

$$h_p = 33.38 \text{ meter of head} = 3.3 \text{ bar}$$

Losses from feed pump till high pressure pump:

Control valve (globe):

$$h = \frac{KV^2}{2g} = 21 \times \frac{1.6^2}{2 \times 9.81} = 2.74 \text{ m} = 0.26 \text{ bar}$$

Gate valves:

$$h = \frac{KV^2}{2g} \times 2 = 2 \times 2 \times \frac{1.6^2}{2 \times 9.81} = 0.52 \text{ m} = 0.05 \text{ bar}$$

Elbows:

$$h = \frac{KV^2}{2g} \times 6 = 6 \times 0.75 \times \frac{1.6^2}{2 \times 9.81} = 0.58 \text{ m} = 0.05 \text{ bar}$$

Pipes:

$$L = 11.5 + 4.9 + 0.75 + 7.25 + 1.5 + 2 = 28 \text{ m}$$

$$h_{\text{pipes}} = \frac{4flv^2}{2D} = \frac{4 \times 0.024 \times 28 \times 1.6^2}{2 \times 0.254} = 13.54 \text{ m} = 1.32 \text{ bar}$$

$$\text{Total losses} = 1.68 \text{ bar}$$

$$\text{Total pressure required from feed pump} = 3.3 + 1.7 = 5 \text{ bar}$$

CIP tank pump:

Type of pump: Radial-flow centrifugal pump

Flow rate: 774.9 GPM

$P = 3 \text{ bar} = 43.5 \text{ psi}$

Material of construction: carbon steel

Casing: cast iron

CIP Tank:

Cleaning chemicals: Alkaline cleaner (RO-cleanL811)

Acidic cleaner (RO-cleanL403)

Minimum liquid rate = 8 m³/hr/vessel with

Maximum head 4 - 5 bar

3.2.2. Energy Recovery System

Pressure exchanger (PX):

Concentrate pressure = 19.29 bar

PX efficiency = 96%

Permeate pressure after PX = 18.5 bar

Booster pump pressure = 4 bar to rise the pressure to 22 bar

Flow rate of feed water to PX = 50% × 7200 = 3600 m³/day

Cost saved by using PX:

For high pressure pump

$$P_{\text{fluid}} = \rho g Q h_p = 1010 \times 9.81 \times 0.083 \times 204$$

$$K \text{ watt/h} = 167,763.94 \text{ watt} = 167.7 \text{ K watt} = \$0.0416$$

$$\text{Cost/day} = 167.7 \times 0.0416 \times 24 = \$167.43$$

$$\text{Cost/year} = \$61,112.56$$

$$\text{PX saved} = \$61,112.56/2 \text{ (for two streams)} = \$30,556.28$$

3.2.3. Calculating the Height and the Diameter of the Tanks

$$V = \frac{\pi}{4} D^2 H$$

Take:

$$D = 1.5H$$

$$3600 = \frac{\pi}{4} (1.5H)^2 \times H - H = 15 \text{ m}, D = 19 \text{ m}$$

For Tanks Shell Thickness:

$$t_{\text{shell}} = \frac{P_d \times R_t}{\sigma_{\text{all}} \times E - 0.6 \times P_d} + C$$

$$t_{\text{shell}} = \frac{1.1 \times 18 \times \left(\frac{748.03}{2} \right)}{15000 \times 0.8 - 0.6 \times 1.1 \times 18} + \frac{1}{16} = \frac{11''}{16}$$

3.2.4. System Details

Feed Flow (m ³ /d)	7200	Permeate Flow (m ³ /d)	3600	Osmotic Pressure						
Raw Water Flow (m ³ /d)	7200	Pass 1 Recovery (%)	50.0	Feed (bar)	4					
Feed Pressure (bar)	21.6	Feed Temperature (°C)	25.0	Concentrate (bar)	8					
Flow Factor	0.8	Feed TDS (ppm)	7230	Average (bar)	6					
(100% H ₂ SO ₄) (ppm)	186.75	Number of Elements	132	Average NDP (bar)	14					
Total Active Area (m ²)	4905.2	Average Flux (lmh)	30	Power (kW)	225					
Water Classification: Well Water SDI < 3				Specific Energy (kWh/m ³)	1.50					
Stage	Element	#PV	# El	Feed Flow (m ³ /d)	Feed Press (bar)	Conc. Flow (m ³ /d)	Conc. Press (bar)	Perm Flow (m ³ /d)	Avg. Flux (lmh)	Perm TDS ppm
1	BW30-400	22	6	7200	21.26	3599	19.14	3600	30	80

Scaling Calculations:

	Raw Water	Adjusted Feed	Concentrate
pH	7.60	6.00	6.21
Ganglier Saturation Index	1.14	-0.78	0.02
Stiff & Davis Stability Index	0.75	-1.17	-0.64
Ionic Strength (Mol)	0.15	0.15	0.30
TDS (ppm)	7275.35	7230.57	14,382.93
HCO ₃	431.34	208.14	412.54
CO ₂	9.02	172.79	172.91
CO ₃	4.60	0.06	0.33
CaSO ₄ (% Saturation)	43.80	47.73	107.91

Material Balance for System:

$$Q_f = Q_p + Q_b$$

$$Q_f \cdot C_f = Q_p \cdot C_p + Q_b \cdot C_b$$

$$300 \times 7230.56 = (150 \times 80.85) + (150 \times 14382.93) - 399$$

$$2169168 = (12127.5 + 2157439.5) - 399$$

$$2169168 = 2169567 - 399$$

399 represent the amount of scaling that occurs on the membrane so by adding anti-scaling this value will be zero. Flow rate of the concentrate recycled to the membrane feed when its concentration is at the low value.

$$300 \times 7230.56 = (300 - Q) \times 4850.57 + Q \times 14382.93$$

$$\text{Flow rate } Q = 75 \text{ m}^3$$

4. Conclusions

By performing multiple variable optimizations, it has been found that the best recovery which gives the highest revenue using the least cost is 50%, the optimum number of membrane elements is 132 distributed in 22 vessel, the number of elements has been chosen per vessel equal to 6 elements to operate at the safe side. Instead of using traditional reverse osmosis plant, it has chosen using an energy recovery device which saves \$30,556.28/year. A degasifier also has been used to reduce the CO₂ content and hence reduces the amount used from NaOH in permeate post treatment.

The conclusion from this work focused in reverse osmosis technique and overviewed in different equipments and chemical pretreatments used it. Safety precautions should be taken in the plant and shutdown-startup procedures were developed. We are presenting the case study to show a real plant to desalinate brackish water using reverse osmosis to yield 3600 m³/day. Multiple variable optimizations are also done on different varieties of membrane system like recovery, flow factor and number of stages. A demonstrated full design for the plant and attached P&ID diagrams with material balance has performed on ROSA software program.

Acknowledgements

We wish to express our sincere thanks and gratitude to the Chemical Engineering Department, Faculty of Engineering, Cairo University for providing help in the course of analyses of this investigation.

References

- [1] Roberts, D.A., Johnston, E.L. and Knott, N.A. (2010) Impacts of Desalination Plant Discharges on the Marine Environment: A Critical Review. *Water Research*, **44**, 5117-5128. <http://dx.doi.org/10.1016/j.watres.2010.04.036>
- [2] Hashim, A. and Hajjaj, M. (2005) Impact of Desalination Plants Fluid Effluents on the Integrity of Seawater, with the

- Arabian Gulf in Perspective. *Desalination*, **182**, 373-393. <http://dx.doi.org/10.1016/j.desal.2005.04.020>
- [3] Safrai, I. and Zask, A. (2008) Reverse Osmosis Desalination Plants-Marine Environmentalist Regulator Point of View. *Desalination*, **220**, 72-84. <http://dx.doi.org/10.1016/j.desal.2007.01.023>
- [4] Cannesson, N., Johnstone, P.M., Mitchell, M.A. and Boerlage, S.F. (2009) Minimizing Community, Environmental, and Marine Impacts at the Gold Coast Desalination Plant, IDA. *Journal of Desalination and Water Reuse*, **1**, 74-87. <http://dx.doi.org/10.1179/ida.2009.1.1.74>
- [5] Tularam, G.A. and Ilahee, M. (2007) Environmental Concerns of Desalinating Seawater Using Reverse Osmosis. *Journal of Environmental Monitoring*, **9**, 805-813. <http://dx.doi.org/10.1039/b708455m>
- [6] Faisal Siddiqui, M., Rzechowicz, M., Harvey, W., Zularisam, A.W. and Anthony, G.F. (2015) Quorum Sensing Based Membrane Biofouling Control for Water Treatment: A Review. *Journal of Water Process Engineering*, **7**, 112-122. <http://dx.doi.org/10.1016/j.jwpe.2015.06.003>
- [7] Tran, N.H., Ngo, H.H., Urase, T. and Gin, K.Y.-H. (2015) A Critical Review on Characterization Strategies of Organic Matter for Wastewater and Water Treatment Processes. *Bio Resource Technology*, **193**, 523-533. <http://dx.doi.org/10.1016/j.biortech.2015.06.091>
- [8] Särkkä, H., Bhatnagar, A. and Sillanpää, M. (2015) Recent Developments of Electro-Oxidation in Water Treatment—A Review. *Journal of Electro analytical Chemistry*, **754**, 46-56. <http://dx.doi.org/10.1016/j.jelechem.2015.06.016>
- [9] Liu, X., Wang, M., Zhang, S. and Pan, B. (2013) Application Potential of Carbon Nanotubes in Water Treatment: A Review. *Journal of Environmental Sciences*, **25**, 1263-1280. [http://dx.doi.org/10.1016/S1001-0742\(12\)60161-2](http://dx.doi.org/10.1016/S1001-0742(12)60161-2)
- [10] Sathwani, J.J., Veza, J.M. and Santana, C. (2005) Case Studies on Environmental Impact of Seawater Desalination. *Desalination*, **185**, 1-8. <http://dx.doi.org/10.1016/j.desal.2005.02.072>
- [11] Miri, R. and Chouikhi, A. (2005) Eco-Toxicological Marine Impacts from Seawater Desalination Plants. *Desalination*, **182**, 403-410. <http://dx.doi.org/10.1016/j.desal.2005.02.034>
- [12] Van Dam, R. and Chapman, J. (2002) Direct Toxicity Assessment (DTA) for Water Quality Guidelines in Australia and New Zealand, Australasia. *Australasian Journal of Ecotoxicology*, **7**, 175-198.
- [13] Warne, M.S.J. (2002) Derivation of the Australian and New Zealand Water Quality Guidelines for Toxicants. *Australasian Journal of Ecotoxicology*, **7**, 123-136.
- [14] Lattemann, S. and Höpner, T. (2008) Environmental Impact and Impact Assessment of Seawater Desalination. *Desalination*, **220**, 1-15. <http://dx.doi.org/10.1016/j.desal.2007.03.009>
- [15] Arup, Olympic Dam Expansion, Supplementary Environmental Impact Statement, Appendix H3 Comparisons with Other Desalination Plants Report Prepared for BHP Billiton Olympic Dam Corporation Pty Ltd., Australia, 2011.
- [16] Trousdale, S. and Henderson, E. (2009) Innovation Addresses Environmental Issues at Sydney Desalination Plant. *IDA Journal of Desalination and Water Reuse*, **1**, 52-63. <http://dx.doi.org/10.1179/ida.2009.1.1.52>
- [17] Mitchell, E.J., Burgess, J.E. and Stuetz, R.M. (2002) Developments in Eco-Toxicity Testing. *Reviews in Environmental Science and Bio/Technology*, **1**, 169-198. <http://dx.doi.org/10.1023/A:1020842718996>
- [18] EPA (2005) Ammonia and Urea Plants, Burrup Peninsula; Change to Split Statement 614 into Two Separate Statements, Section 46 Report and Recommendations of the Environmental Protection Agency, October 2005, Perth.
- [19] Arup/ENSR, Olympic Dam Expansion, Draft Environmental Impact Statement 2009, Main Report Volume 1, Report Prepared for BHP Billiton Olympic Dam Corporation Pty Ltd, December 2008, Australia, 2009.
- [20] Chapman, P.M. (2000) Whole Effluent Toxicity Testing-Usefulness, Level of Protection, and Risk Assessment. *Environmental Toxicology and Chemistry*, **19**, 3-13. <http://dx.doi.org/10.1002/etc.5620190102>
- [21] Sánchez-Lizaso, J.L., Romero, J., Ruiz, J., Gacia, E., Buceta, J.L., Invers, O., Fernández Torquemada, Y., Mas, J., Ruiz-Mateo, A. and Manzanera, M. (2008) Salinity Tolerance of the Mediterranean Sea Grass *Posidonia oceanica*: Recommendations to Minimize the Impact of Brine Discharges from Desalination Plants. *Desalination*, **221**, 602-607. <http://dx.doi.org/10.1016/j.desal.2007.01.119>
- [22] Falkenberg, L.J. and Styan, C.A. (2015) The Use of Simulated Whole Effluents in Toxicity Assessments: A Review of Case Studies from Reverse Osmosis Desalination Plants. *Desalination*, **368**, 3-9. <http://dx.doi.org/10.1016/j.desal.2015.01.014>