

TECHNICAL MANUAL

WATER DESALINATION

H E A D Q U A R T E R S , D E P A R T M E N T O F T H E A R M Y

SEPTEMBER 1986

REPRODUCTION AUTHORIZATION/RESTRICTIONS

This manual has been prepared by or for the Government and, except to the extent indicated below, is public property and not subject to copyright.

Copyrighted material included in the manual has been used with the knowledge and permission of the proprietors and is acknowledged as such at point of use. Anyone wishing to make further use of any copyrighted material, *by itself and apart from this text*, should seek necessary permission directly from the proprietors.

Reprints or republications of this manual should include a credit substantially as follows:
"Department of the Army, USA, Technical Manual TM 5-813-8, Water Desalination.

If the reprint or republication includes copyrighted material, the credit should also state:
"Anyone wishing to make further use of copyrighted material, *by itself and apart from this text*, should seek necessary permission directly from the proprietors."

WATER DESALINATION

	Paragraph	Page
CHAPTER 1.	GENERAL	
	Purpose	1-1 1-1
	General design considerations	1-2 1-1
	Special design considerations	1-3 1-1
	Economic considerations	1-4 1-1
	Appendices	1-5 1-1
CHAPTER 2.	SITE SELECTION	
	Site technical requirements	2-1 2-1
	Water storage and system modularization	2-2 2-1
CHAPTER 3.	WATER SOURCE SELECTION	
	General.....	3-1 3-1
	Quality.....	3-2 3-1
	Selection versus rejection of potential raw water sources.....	3-3 3-1
CHAPTER 4.	PROCESS SELECTION	
	General process selection.....	4-1 4-1
	Process limitations.....	4-2 4-2
	Distillation/condensation energy.....	4-3 4-3
	Membrane energy.....	4-4 4-5
	Waste disposal	4-5 4-5
	Preliminary process selection.....	4-6 4-5
	Process selection.....	4-7 4-5
CHAPTER 5.	PRETREATMENT CONSIDERATIONS	
	General.....	5-1 5-1
	Chemical treatment.....	5-2 5-1
	Degasification and deaeration	5-3 5-5
	Filtration with granular media	5-4 5-5
	Secondary filtration	5-5 5-5
	Disinfection.....	5-6 5-6
CHAPTER 6	DISTILLATION/CONDENSATION TECHNIQUES	
	General.....	6-1 6-1
	High-temperature distillation	6-2 6-1
	Low-temperature distillation	6-3 6-1
	Mechanical distillation.....	6-4 6-1
	Thermal discharge	6-5 6-7
	Design analysis.....	6-6 6-7
	Materials of construction	6-7 6-7
	Distillation/condensation system design	6-8 6-7
CHAPTER 7.	MEMBRANE TECHNIQUES	
	Electrodialysis.....	7-1 7-1
	Electrodialysis-reversal design.....	7-2 7-1
	Reverse osmosis	7-3 7-3
	Reverse osmosis membrane staging configurations.....	7-4 7-7
	Reverse osmosis system design	7-5 7-11
	Materials of construction	7-6 7-13
CHAPTER 8.	ION EXCHANGE	
	General.....	8-1 8-1
	Pretreatment.....	8-2 8-1
	Desalination.....	8-3 8-2
	Deminalization.....	8-4 8-5

CHAPTER 9.	POST-TREATMENT		
	General.....	9-1	9-1
	Remineralization and aeration	9-2	9-1
	Post-treatment of distilled water	9-3	9-1
	Post-treatment of reverse osmosis product water	9-4	9-1
	Post-treatment of electrodialysis-reversal product water.....	9-5	9-3
CHAPTER 10.	WASTE DISPOSAL		
	General.....	10-1	10-1
	Pretreatment wastes	10-2	10-2
	Distillation/condensation system wastes	10-3	10-3
	Membrane system wastes	10-4	10-5
	Ion-exchange system wastes	10-5	10-6
	Ultimate disposal	10-6	10-6
APPENDIX A.	SAMPLE PROBLEMS		A-1
APPENDIX B.	WATER TESTING REQUIRED FOR DESALINATION TREATMENT		B-1
APPENDIX C.	REFERENCES		C-1
BIBLIOGRAPHY		Biblio-1

LIST OF FIGURES

FIGURE	2-1	Typical Desalination Flowsheet
	2-2	Typical Reverse Osmosis Desalination System
	4-1	Energy Consumption
	5-1	Pretreatment Techniques
	5-2	Approximate Concentration Factor Limits for Calcium Sulfate in Sea Water
	5-3	Disinfection Alternatives
	6-1	Three Methods of Vaporization
	6-2	Multiple-Effect Vertical-Tube Evaporation Process
	6-3	Multistage Flash Distillation Facility
	6-4	Waste Heat Recovery Evaporation Process
	6-5	Vapor-Compression Vertical-Tube Distillation System
	7-1	Principles of Electrodialysis Desalination
	7-2	Reverse Osmosis Principles
	7-3	Reverse Osmosis Desalination System
	7-4	Flow-Work Exchanger Principles
	7-5	Construction of a Tubular Reverse Osmosis Membrane
	7-6	Internal Construction of a Spiral-Wound Membrane
	7-7	Internal Construction of a Hollow Fine-Fiber Reverse Osmosis Membrane Module
	7-8	Reverse Osmosis Product Staging
	7-9	Reverse Osmosis Membrane Reject Staging
	8-1	Principles of Ion-Exchange Processes
	8-2	RDI Process
	8-3	Three-Unit Variation Desal Process
	8-4	Two-Unit Variation Desal Process
	8-5	Demineralization Two-Bed Flowsheet
	9-1	Break-Point Chlorination Curve
	10-1	Waste Disposal Overview
	10-2	Pretreatment Sludge Disposal
	10-3	Deep-Well Disposal Unit
	10-4	Brine Waste Disposal
	A-1	Sample Use of Table 4-1
	A-2	Sample Use of Table 4-2
	A-3	Water Analysis (Sample Problem A-1a)
	A-4	Sample Use of Table 4-3
	A-5	Water Analysis (Sample Problem A-1b)
	A-6	Water Analysis (Sample Problem A-1c)
	A-7	Low-Pressure Reverse Osmosis System
	A-8	Sample Use of Table 4-1
	A-9	Water Analysis (Sample Problem A-2)
	A-10	Sample Use of Table 4-2
	A-11	Sample Use of Table 4-3
	A-12	Plan View of Vapor Compression System
	A-13	Water Analysis (Sample Problem A-4)
	A-14	Amberlite IR-120 Plus Leakage Data Regeneration-5 lbs. H_2SO_4 (66° Be)/cu. ft.
	A-15	Amberlite IR-120 Plus Iso-Capacity Data Regeneration-5 lbs. H_2SO_4 (66° Be)/cu. ft.
	A-16	Amberlite IR-120 Plus Capacity Correction for Alkalinity
	A-17	Amberlite IR-120 Plus Leakage Data Regeneration-3 lbs. H_2SO_4 (66° Be)/cu. ft.
	A-18	Amberlite IR-120 Plus Iso-Capacity Data Regeneration-3 lbs. H_2SO_4 (66° Be)/cu. ft.
	A-19	Amberlite IR-120 Plus Capacity Correction for Alkalinity
	A-20	Cation Exchangers Plan
	A-21	Degasifier and Clearwell Plan

FIGURE A-22 Three Projections of the Water Blends That Satisfy TB MED 576 Requirements
 A-23 Plan View of a Two-Pass Reverse Osmosis System

LIST OF TABLES

Table	4-1	Preliminary Desalination Process Selection
	4-2	Selecting Desalination Processes after Water Quality Data are Obtained
	4-3	Final Selection of a Desalination Technique from Treatability Data
	5-1	The Maximum Allowable Contaminants in the Feed Water Used by Various Desalination Processes
	A-1	Water Constituents at Treatment Stages with 5 Pounds/Cubic Foot Acid Regeneration
	A-2	Water Constituents at Treatment Stages with 3 Pounds/Cubic Foot Sulfuric Acid Regeneration
	A-3	Cost Projections for Possible Optimum Blends

CHAPTER 1

GENERAL

1-1. Purpose. This manual describes the guidelines to be followed in selecting a process capable of producing potable water supplies from brackish and sea water sources. Potable water is defined in TB MED 576. Army potable water quality requirements can be found in TB MED 576. Information on required pre- and post-treatment design, water distribution, and storage can be found in the TM 5-813 series.

1-2. General design considerations. All desalination facilities will be designed as simply as possible and will produce a final product water in keeping with operational needs. Desalination process selection will be site-specific and will include evaluations of product quality and quantity, raw feed water sources, and available energy sources. Potable water will contain less than 500 milligrams per liter of total dissolved solids (TDS). (One milligram per liter is equal to one part per million.) Technological processes not covered in this TM that are proposed for selection must be approved by DAENECE-G.

1-3. Special design considerations. When facilities require improved water quality, such as boiler feed water or medical facility waters, additional water treatment systems will be installed.

1-4. Economic considerations. The selection of one particular type of design for a water desalination system/subsystem, when two or more types of design are known to be feasible, must be based on the results of an economic study, in accordance with the requirements of DOD 4270.1-M and PL 95-619, 9 Nov 78. The results of these economic studies are to be included in the design/analysis documentation for the project. All such studies are to be conducted in accordance with HQDA's economic-studies criteria for Military Construction Program (MCP) designs. Clarification of HQDA criteria for a particular application or supplementary criteria and guidelines that may be required for special cases may be obtained by request through normal channels to HQDA (DAENECE-G), Wash. DC 20314-1000.

1-5. Appendices. Appendix A contains sample problems illustrating use of information presented in this document. Various tests and analyses required or used in desalination treatment of water are listed in Appendix B. Appendix C contains a list of references used in this document.

CHAPTER 2

SITE SELECTION

2-1. Site technical requirements. Site technical requirements are specific to each particular process. Generalized recommendations can be made regarding location, space, and access requirements. A typical desalination system flowsheet is shown in figure 2-1. A typical desalination system layout, using reverse osmosis as a sample process, is shown in figure 2-2.

a. Location. Desalination facilities will be located as close to the raw water source as possible in order to avoid excessive pipeline or pumping costs and to minimize operation and maintenance costs for pumping raw water (high saline content). The placement of desalination facilities within the perimeter of a military reservation will provide facility security. Topography should be considered in the siting of a desalination facility, and gravity flow should be used where possible.

b. Space requirements. The space required for desalination facilities is determined by the process. Membrane desalination equipment needs less space than distillation/condensation desalination equipment. In general, space requirements are less for the desalination equipment than for a conventional surface water treatment plant of the same capacity. An exception is solar desalination systems. These systems employ solar collectors that require an area several times greater than other types of desalination equipment in order to achieve equal capacity.

c. Access. Access to systems must be provided to permit routine maintenance, sludge and brine removal, and delivery of desalination equipment and supplies. The access requirements for desalination facilities are similar to those for conventional water treatment facilities.

2-2. Water storage and system modularization.

a. Equipment downtime. In all distillation/condensation and many membrane desalination plants, storage will be determined by equipment downtime when equipment downtime is more than 1 day. To determine the necessary storage, establish the longest period of time that could be required for planned or unplanned maintenance. Calculate the storage by multiplying this time period by the water demand rate.

b. Peak daily demands. When maximum equipment downtime is less than 1 day, the peak daily demands may set a larger storage demand. When these peak demands set the storage requirements, refer to water storage in the TM 5-813 series.

c. Fire water storage. On a facility served by a desalination system, fire water may be saline water or potable water depending on economic analysis. Dual water distribution system will be required if saline water is used. Hence, part of the fire protection water can be either saline or potable water due to piping and pumping cost. Economic evaluation of various design alternatives is usually needed to assure the optimal design to be adopted.

d. System redundancy and modularization. One complete and functional desalination module in excess of that required to supply the design flow will be provided as redundant capacity, and all desalination systems will have a minimum of three independently functioning desalination modules where practicable.

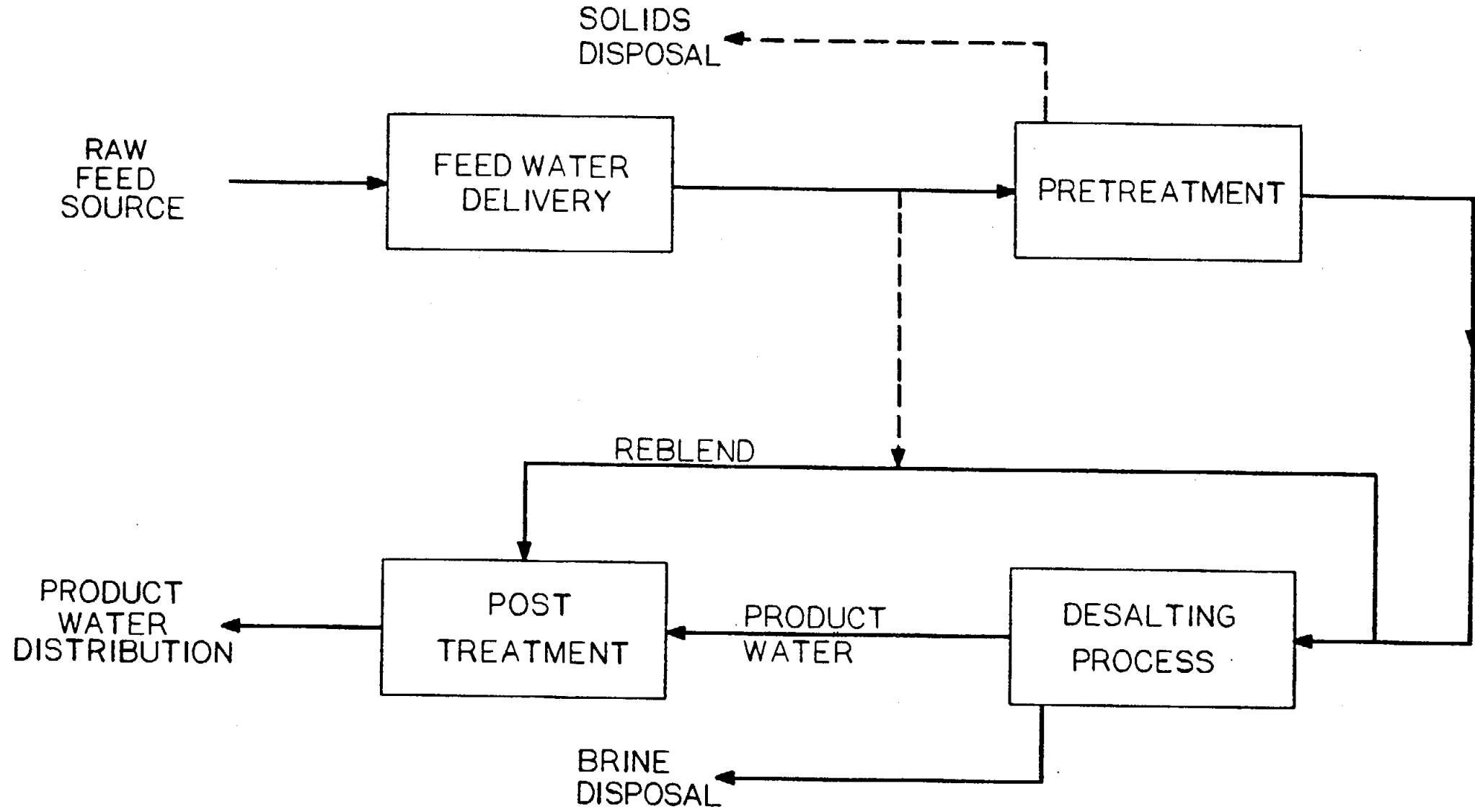
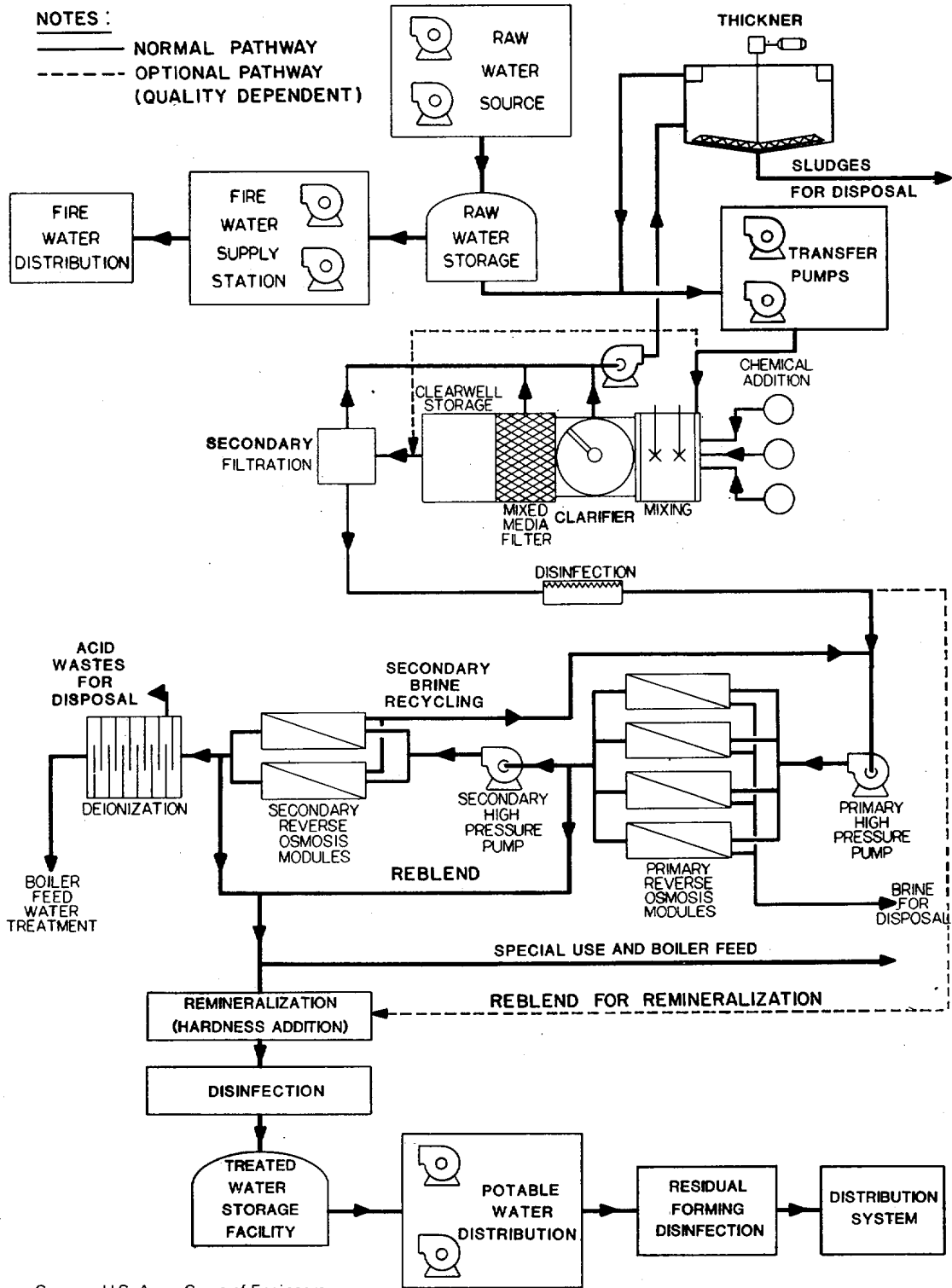

Figure 2-1. Typical desalination flowsheet.



Source: U.S. Army Corps of Engineers

Figure 2-2. Typical reverse osmosis desalination system.

CHAPTER 3

WATER SOURCE SELECTION

3-1. General. The selection of a water supply will be based on available quantity, quality, and cost of development. Investigate usable fresh surface water and groundwater thoroughly, prior to consideration of sources requiring desalination. When fresh water sources do not exist, consider saline water sources. The most commonly used parameter to differentiate between saline water qualities is total dissolved solids (TDS). The total dissolved solids is defined as the sum of the dissolved organic materials and the inorganic salts. Fresh waters contain less than 1,000 milligrams per liter of total dissolved solids. Brackish water contain 1,000-20,000 milligrams per liter of total dissolved solids. Sea water usually contains at least 20,000 milligrams per liter of total dissolved solids. Quantities of potable water needed will be determined by an analysis of the site in accordance with TM 5-813-1. The quantity of saline feed water necessary to produce the required quantity of product water is addressed in Chapter 4.

3-2. Quality. The quality will be determined by the planned use. Physical, chemical, and bacteriological testing of source waters are required to determine the level of treatment to supply the necessary water quality. When the quantity withdrawn exceeds the recharge rate, quality inherently decreases; therefore, this must be considered during design.

a. Physical characteristics. The physical characteristics of the raw water source that must be evaluated are total suspended solids (TSS) and temperature. Turbidity and silt density index (SDI).

(1) Total suspended solids. The total suspended solids level of raw water sources must be evaluated to determine the level of pretreatment processes required. Raw water having low total suspended solids levels generally requires less pretreatment. The source with the lowest total suspended solids is preferred.

(2) *Temperature.* The temperature of the raw water source must be matched to the specific desalination process. In extreme cases, the water temperature may control the desalination process selection. A climatological survey must be made prior to finalization of process selection to determine the seasonal maximum and minimum water temperatures of the proposed water sources.

(3) *Turbidity and silt density index.* These two characteristics provide two different measures of the amount of fine particulate matter in the water. Turbidity is measured in nephelometric turbidity units (a measure of the amount of light scattered by a known water sample thickness). Silt density index is a measure of the amount of 0.45-micron filter plugging caused by passing a sample of water through the filter for 15 minutes. Turbidity must be determined for all desalination processes. Also, the silt density index must be determined for water being considered for reverse osmosis treatment.

b. Chemical constituents. The chemical constituents of the raw water must be determined to provide information for treatment selection. Appendix B shows the water testing analyses required for desalination treatment.

c. Bacteriological quality. The bacteriological testing of the raw water must include a type of a coliform indicator organism count. Procedures for filter membrane, most probable number fermentation tube, and standard plate count, coliform organism bacteriological testing techniques can be found in Standard Methods for the Examination of Water and Wastewater and TB Med 576. Manufacturers' recommendations as to the media and procedures used to identify microbiological activity detrimental to the operation of a particular desalination system shall be followed.

3-3. Selection versus rejection of potential raw water sources. After the completion of physical, chemical, and bacteriological testing, a final water source may be selected. Extreme care must be taken in the selection of a source where the usage rate is greater than the recharge rate. In most cases, selection will involve choosing the brackish water with the lowest level of total dissolved solids. When brackish water is not available, use sea water or water as saline as sea water as the feed water source. When the coliform indicator organism count of a water is greater than 10,000 most probable number (MPN), then the water source should be rejected for sanitary reasons and a more saline water chosen (per Standard Methods for the Examination of Water and Wastewater and TB MED 576). If other water is available, a water containing more than 1,000 nephelometric turbidity units should be rejected on the basis of the high cost and difficulty of

clarification, even if the alternative water is more saline. When the total delivery pumping pressure of a less saline water is greater than the operating pressure of a reverse osmosis system, then the desalination of the more saline water by reverse osmosis may be more economical than the combined cost of delivery and

desalination of the less saline source. The final selection of a raw water source will be based on economic studies. In some cases, the decision cannot be made until all systems are fully designed and life cycle costed.

CHAPTER 4
PROCESS SELECTION

4-1. General process selection. In selecting a potable water production system, it is important to estimate costs of various options. The conventional unit of comparison is cost in dollars per 1,000 gallons of product water. Water quality and energy sources will be estimated from simple site reconnaissance. For example, a sea coast site where the water source temperature exceeds 95 degrees Fahrenheit indicates a high-salinity high-temperature combination favoring distillation/condensation processes. Reverse osmosis requires a feed water temperature below 95 degrees Fahrenheit. If local well testing indicates salinity between 500 and 3,000 milligrams per liter and electricity is inexpensive, electrodialysis reversal or highflux reverse osmosis is indicated.

a. Desalination requirements. The design of a desalination system requires a clear understanding of the following: the quantity of product water desired; the quality of the desired product; and the quality of the feed water source. This manual addresses the production of potable water containing less than 500 milligrams per liter of total dissolved solids. Laundries, boilers, mess halls, and hospitals may require water purer than 500 milligrams per liter of total dissolved solids. Potable water from the desalination system may be further treated to meet these requirements in accordance with AR 420-46.

b. Saline feed water quantity. The production of potable water from saline water usually requires a significantly larger quantity of saline feed water than the quantity of potable water produced. When desalination is necessary to produce potable water, the process splits the feed water into two streams. One stream is the product water; the other stream is the brine that contains most of the salts originally in the feed water. In waters that need very little desalination, high-rate reverse osmosis may only reject 5 percent of the feed stream as brine. In reverse osmosis of sea water, more than 70 percent of the intake water may be rejected as brine. Multiply the required product quantity by the reciprocal of the product water recovery fraction to find the quantity of saline water that must be processed to yield the desired quantity of product water. In equation form, it can be expressed as follows:

$$\frac{100\%}{\% \text{ recovery of product water}} \times \text{water demand} = \text{saline feed water flow}$$

In some cases, the limited quantity of an available saline water may require a decision to adopt a more expensive desalination process with a higher water recovery rate. However, it may require choosing a different and more saline feed water with a greater availability.

c. Blending of waters. Blending a high concentration stream with a low concentration stream wastes the osmotic pressure energy between the two streams. Therefore, it is best to match the design of the desalination system to the product quality desired. When a desalination process cannot be economically matched to the desired product quality, then a process that yields water with a very low dissolved material content must be used. To conserve capital and equipment costs and meet the desired water demand, the high purity product water can be blended with the pretreated saline feed water to produce the required product quantity and quality. The following equation can be used to calculate the concentration of a blended water stream:

$$\left(\sum_{i=1}^{i=n} \text{concentration } i \times \text{flow } i \right) / \text{total flow} = \text{blended concentration}$$

When only two streams are blended, the equation can be rearranged to show the flow of concentrated water that when blended with a dilute flow will result in the desired product concentration. This rearranged equation is as follows:

$$\frac{(P - H)(D)}{C - P} = F$$

Where:

- P = Desired product water concentration
- H = High purity water concentration
- D = Flow of the high purity water
- C = Concentration in the impure concentrated stream
- F = Flow rate of the concentrated stream

Reblending for remineralization is discussed in Chapter 9. The same blend equations will apply to blending

for remineralization, which is a more common procedure. See Appendix A for sample problems.

4-2. Process limitations. The various desalination processes presently available have limitations that must be considered prior to selecting a desalination process for a particular site. These limitations apply only to the desalination processes themselves; pretreatment can be and is often used to bring a saline feed water within limits so that a desalination process can be used. The raw feed water chemistry for all desalination systems must be evaluated thoroughly for constituents that may precipitate in the desalination system.

a. High-temperature distillation. High-temperature distillation is limited by the saturation of alkaline earth metal salts, such as CaSO_4 , BaSO_4 , SrSO_4 , CaCO_3 , BaCO_3 , and SrCO_3 . Carbonate salt scaling can be controlled by acid addition. The recovery of water from a high-temperature distillation plant is usually limited by calcium sulfate solubility. When the concentration of the sulfate and the limiting alkaline earth metal is one-third of the saturated condition at ambient temperature, distillation design must include pretreatment to reduce or inhibit the scaling ions. High-temperature distillation is also limited to oil and grease levels below 1 milligram per liter. All other limitations on the high-temperature distillation process are equipment specific and require individual evaluation.

b. Low-temperature and mechanical distillation. Low-temperature and mechanical distillation systems are limited to operation below saturation of alkaline earth sulfates and carbonates. The lower operating temperature permits economical operation on waters that are at or below half saturation at ambient temperature. Oil and grease are limited to less than 1 milligram per liter. Any other limitations are equipment specific.

c. Reverse osmosis. The most severe limitation on reverse osmosis is the maximum limit of 50,000 milligrams per liter of total dissolved solids in the feed water. Another limitation is that there must be no iron in the feed water. This limitation is so rigid that only stainless steel and nonferric materials will be used downstream of the iron removal. The solubility of alkaline earth sulfates and carbonates limits reverse osmosis treatment. Any water containing less than 4,000 milligrams per liter of total dissolved solids that would be saturated with an alkaline earth sulfate when the concentration is multiplied by 1.5 should not be considered for reverse osmosis desalination. Reverse osmosis is limited to waters that do not have silica saturation in the reject brine. Silica chemistry is

extremely complex. When the molybdenum reactive silica concentration exceeds 30 milligrams per liter as SiO_2 or the pH exceeds 8.3 in the brine stream, an environmental chemist or engineer should be consulted. Reverse osmosis is also limited to the treatment of waters with less than 1 milligram per liter of oil and grease.

(1) Cellulose acetate membranes. Cellulose acetate membranes are usually limited to pH levels between 4.0 and 7.5. Cellulose acetate membranes require some form of continuous disinfection with the feed water to prevent microbial degradation of the membranes and can tolerate up to 1 milligram per liter of free chlorine. Therefore, cellulose acetate membranes are usually disinfected by maintaining 0.2 to 0.9 milligrams per liter of free chlorine in the feed water. Cellulose acetate membranes cannot be used on waters where the temperature exceeds 88 degrees Fahrenheit. Cellulose acetate membranes should not be used at pressures greater than the manufacturer's recommended pressure, since they are prone to membrane degradation by pressure compaction.

(2) Polyaromatic amide membranes. Brackish water polyaromatic amide membranes are generally limited to operation in feed waters between pH 4 and pH 11. Polyaromatic amide membranes are less pH tolerant and should not be used outside of the range pH 5 to pH 9. All polyaromatic amide membranes are limited to use on feed streams that are free of residual chlorine. If chlorination is necessary or desirable as a pretreatment option, complete dechlorination must be effected. Polyaromatic amide membranes are tolerant of water temperatures up to 95 degrees Fahrenheit. While polyaromatic amide membranes are not as quickly or completely compacted as are cellulose acetate membranes, manufacturer's recommended pressures must be followed to prevent mechanical damage to membrane modules.

d. Electrodialysis reversal. While electrodialysis reversal has been used to treat water as saline as sea water, 4,000 milligrams per liter of total dissolved solids is considered to be an upper limit for economical operation. Some electrodialysis membranes can tolerate strong oxidants, like chlorine, but most cannot. The reversal of polarity used in electrodialysis reversal for removal of scale allows operation on water that is saturated with alkaline earth carbonates. Saturation

with an alkaline sulfate with low carbonate alkalinity should be avoided.

4-3. Distillation/condensation energy. In distillation/condensation plants, energy is used in the form of steam and elec

tricity. Steam is used to heat the saline water to increase its vapor pressure. Normally, electricity is used to run the compressor in vaporcompression distillation. If excess steam is available, its use as a power source should be

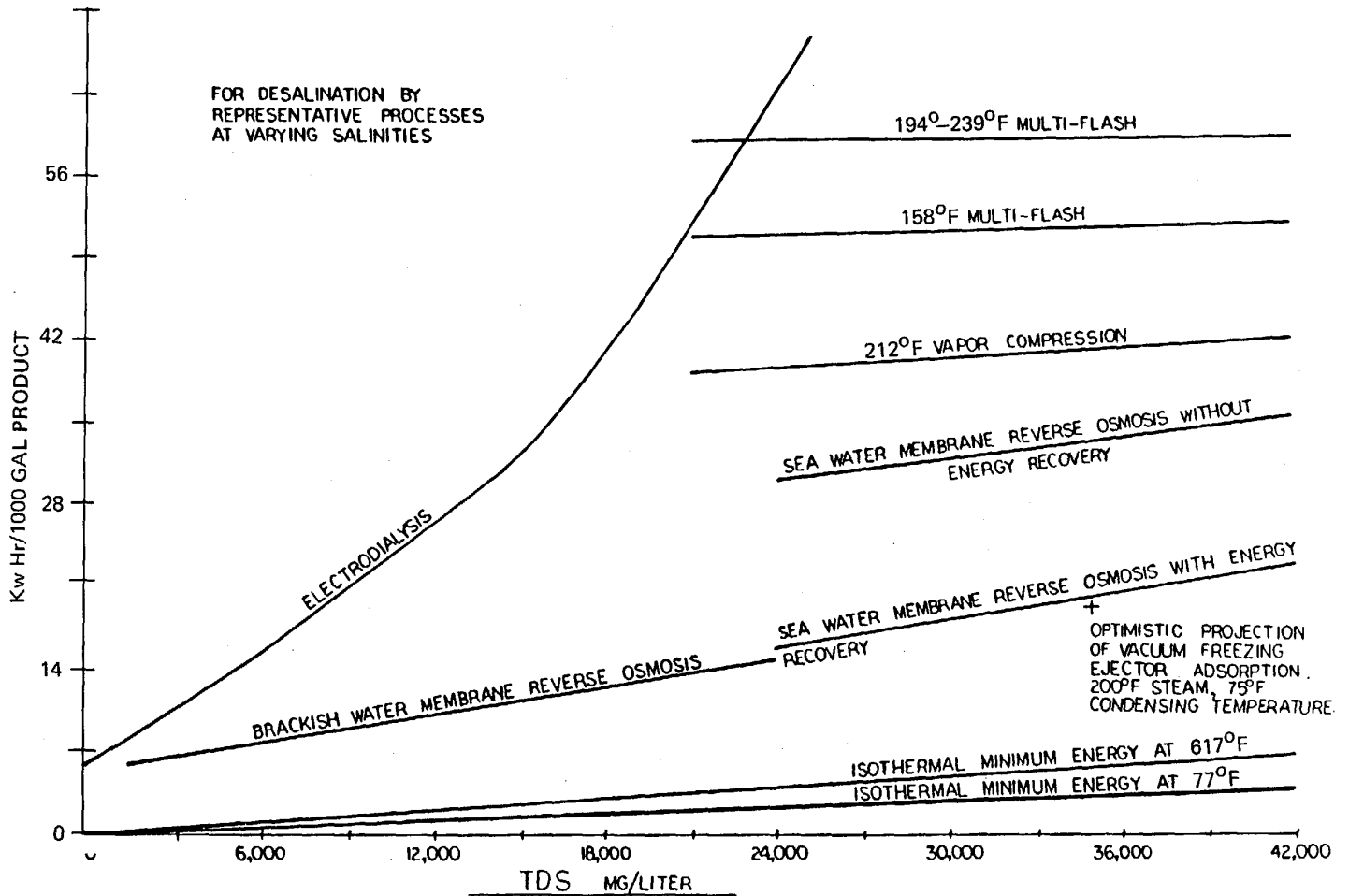

Figure 4-1. Energy consumption.

RULE	A	B	C	D	E	F
	If the freshest source of water is:	And if the desired output water will be:	And if electricity is to be generated:	And if the projected cost ratio of <u>264°F Steam:</u> Electricity	Then investigate the cost of:	And have the following tests performed:
1	More salty than sea water	Potable water			Transportation of fresher water: distillation can be used but at great expense	TDS
2	Sea water	High-pressure boiler feed water	By steam turbine		Distillation followed by ion exchange	TDS, Ca ⁺⁺ , SO ₄ ⁻ , CO ₃ ⁻ , pH refer to water testing requirements in Appendix B
3	Sea water	Potable water	By steam turbine	Greater than <u>10 x 10⁶ BTU</u> 1 kwh	Thermal distillation with or without vapor compression	TDS, Ca ⁺⁺ , SO ₄ ⁻ , CO ₃ ⁻ , pH
4	Sea water	Potable water	By internal combustion engine		Vapor compression distillation and waste heat	TDS, bacterial count, turbidity
5	Sea water	Potable water	No	Less than <u>10 x 10⁶ BTU</u> 1 kwh	Reverse osmosis	TDS, Ca ⁺⁺ , SO ₄ ⁻ , CO ₃ ⁻ , pH, bacterial count, silt density index, turbidity, oil & grease refer to list for reverse osmosis, Appendix B
6	Brackish water	Potable water			Reverse osmosis	TDS, Ca ⁺⁺ , SO ₄ ⁻ , CO ₃ ⁻ , pH, bacterial count, silt density index, turbidity, oil & grease
7	Slightly saline brackish water	Potable water			Electrodialysis reversal	TDS, full ionic breakdown, bacterial count, turbidity refer to list for electrodialysis reversal, Appendix B

Table 4-1. Preliminary desalination process selection.

investigated. The amount of electricity or mechanical work that steam will yield depends on its temperature as well as the temperature to which it can be condensed. The energy consumption of both vapor compression and thermal distillation, as related to the total dissolved solids of feed water, is shown in figure 4-1.

4-4. Membrane energy. Historically, membrane desalination systems use less energy than other systems. Brackish water desalination should be accomplished by membrane separation processes because of the reduced energy requirement. The energy consumption of electrodialysis reversal can be made to follow reduced or variable salinity, while the energy consumption of reverse osmosis is set principally by membrane water flux. Again, the energy consumption of electrodialysis reversal and reverse osmosis as a function of the total dissolved solids content of the feed water is shown in figure 4-1. As membrane materials are developed, energy consumption may be reduced.

4-5. Waste disposal. Waste disposal may influence process selection. Since brine disposal costs can be an important part of process economics, brine disposal alternatives must be explored while water quality analyses are being performed. For further information, refer to Chapter 10 on waste disposal.

4-6. Preliminary process selection. Use preliminary site information to eliminate certain desalination processes. A decision logic table for use with preliminary information is shown in table 4-1. Decisions based upon table 4-1 are to be considered preliminary only. Necessary water quality tests to further support the recommendations made in Column E of table 4-1 are in Column F.

4-7. Process selection. When initial site and raw water source selections have been made, use preliminary water quality information with table 4-1 to assist in a preliminary process selection. As more specific information is obtained from laboratory analyses of water quality, make an initial process selection using the second decision logic table, table 4-2. After a treatability investigation has been completed, select the final desalination process. A final decision logic table, table 4-3, assists in the final process selection. The use of the decision logic table sequence will only provide generalized assistance in process selection; additional economic, engineering, and environmental studies may indicate that methods or combinations of methods must be used.

RULE	A	B	C	D	E	F
	If the feed water TDS is (mg/liter):	And if the raw feed water suspended solids are:	And if the product of the $[Ca^{++}][SO_4^-]$ moles ² /liter ² is in the reject brine (see sample problem A-3)	And if the oil and grease in the raw feed water is:	Then investigate the cost of:	And have the following pretreatment processes investigated for effectiveness:
1	Greater than 50,000				Transportation of fresher water; distillation of this water is extremely expensive	Precipitation of less soluble salts
2	Between 20,000 - 50,000	Over 20 NTU	Considerably less than 2×10^{-4}	Greater than 10 mg/liter	Reverse osmosis or distillation and steam and electricity	Alum jar tests, pH adjustment 10-micron or smaller filter plugging
3	Between 20,000 - 50,000	Over 1 NTU		Less than 10 mg/liter	Reverse osmosis	Alum jar tests 10-micron or smaller filter plugging UV sterilization
4	Between 20,000 - 50,000	Less than 1 NTU SDI greater than 3		Less than 10 mg/liter	Spiral-wound membrane reverse osmosis	pH adjustment, UV sterilization, chlorine disinfection, chlorine residual
5	Between 20,000 - 50,000	SDI under 3		Less than 10 mg/liter	Hollow fine-fiber membrane reverse osmosis	10-micron or smaller filter test, UV sterilization
6	Between 3,000 - 20,000	Over 1,000 mg/liter	Considerably less than 2×10^{-4}	Greater than 10 mg/liter	Distillation	pH adjustment, alum jar test
7	Between 3,000 - 20,000			Less than 10 mg/liter	Reverse osmosis	pH adjustment, alum jar test, silt density index, UV sterilization
8	Between 500 - 4,000				Electrodialysis reversal	pH adjustment, alum jar test, 10-micron filter plugging, chlorine disinfection

Table 4-2. Selecting desalination processes after water quality data are obtained.

RCR	A	B	C	D	E	F	G
	If the treated feed water salinity (mg/l) will be (see note):	And the cost ratio of 264°F steam 1 kwh electricity will be:	Alkaline earths on the raw water are such that (see sample problem A-3):	And the treated suspended solids are:	And the designated chlorine residual is:	Then investigate the cost of:	With the following pre- and post-treatment technique costs:
1	Between 20,000 - 50,000		Within 66% of saturation	Less than 1 NTU but SDI greater than 3	0.0 mg/liter	Spiral-wound membrane reverse osmosis	Whatever treatment is necessary to produce D and E
2	Between 20,000 - 50,000		Within 66% of saturation	SDI less than 3	0.0 mg/liter	Hollow fine-fiber membrane reverse osmosis	Whatever treatment is necessary to produce D and E
3	Between 20,000 - 50,000		Within 50% of saturation	Less than 1 NTU	Between 1.0 and 0.0 mg/l	Chlorine-resistant membrane reverse osmosis	Whatever treatment is necessary to produce D and E
4	Between 20,000 - 50,000	Greater than 10×10^6 BTU 1 kwh	Within 50% of saturation	Greater than 1 NTU	More than 1 mg/l	Some form of distillation under 185°F	Anti-scalent
5	Between 20,000 - 50,000	Greater than 10×10^6 BTU 1 kwh		Greater than 1 NTU	More than 1 mg/l	Some form of distillation	Acid feed (hydrochloric is best)
6	Between 20,000 - 50,000	Greater than 10×10^6 BTU 1 kwh	[Ca ⁺⁺] multiplied by [SO ₄ ⁻] Well Under 2×10^{-6}	Greater than 1 NTU	More than 1 mg/l	Some form of distillation	No pretreatment for calcium sulfate scale control
7	Between 3,000 - 20,000			Less than 1 NTU but SDI greater than 3	Less than 1.0 mg/l**	Brackish water spiral-wound membrane reverse osmosis	Whatever treatment is necessary to produce D and E
8	Between 3,000 - 20,000			SDI less than 3	Less than 1.0 mg/l**	Brackish water hollow fine-fiber membrane reverse osmosis	Whatever treatment is necessary to produce D and E
9	Between 500 - 4,000 and especially when expected to vary by more than 15%			Will not plug 10-micron filter	0.0 mg/l**	Electrodialysis reversal	Turbidity removal To 1 NTU and disinfection to less than 1/100 ml.
10	Is stable at some value between 500 - 1000			SDI less than 3	Less than 1.0 mg/l**	Low pressure/high flux membrane reverse osmosis	Whatever treatment is necessary to produce D and E

Table 4-3. Final selection of a desalination technique from treatability data.

CHAPTER 5

PRETREATMENT CONSIDERATIONS

5-1. General. Before raw water is desalinated, the undesirable materials will be removed or reduced to acceptable levels. Such materials to be removed include solids, immiscible liquids, and sparingly soluble salts. Accumulations of these materials on desalination process surfaces greatly reduce efficiencies. Without adequate pretreatment, desalination facilities are destined for reduced lifetimes, shortened periods of operation, and high maintenance. The feedwater limitations for various desalination processes are summarized in table 5-1. An overview of typical pretreatment options is shown in figure 5-1.

a. Solids. Physical and chemical treatment processes will be used to remove solid materials. The level of solids removal will depend on the desalination process to be used.

(1) *Settleable solids.* Settleable solids are easily removed from water by gravity settling or filtration.

(2) *Non-settleable solids.* Non-settleable solids are removed by chemical treatment. Chemical treatment may be designed to remove not only non-settleable solids but to precipitate and remove scale-forming solids.

b. Immiscible liquids. Emulsified oil and grease are the principle sources of immiscible liquid fouling in desalination facilities. Use gravity settling and chemical treatment processes followed by a filtration system to maintain immiscible liquid concentrations within acceptable levels. To measure low levels of oil and grease, a sophisticated concentration procedure must be performed.

c. Dissolved organic contaminants. The most common organic materials, tannins and humic acids, can be removed from water by chemical treatment. Some organic materials will carry across a distillation/condensation process with the water. Pesticides and industrial organic chemicals may be difficult to remove by distillation/condensation. Reverse osmosis will usually remove the majority of the large pesticide molecules. If during pretreatment tests a non-ionized organic contaminant is not reduced to acceptable levels, then a full treatability investigation will be performed to ensure that potable water standards are met.

d. Sparingly soluble salts. As physical and chemical conditions change during desalination, some soluble materials become insoluble (precipitate). This precipitation of solid materials can foul desalination

systems through the formation of scale. Materials that precipitate easily to form scale are double-charged positive ions, such as calcium and magnesium salts. As water volume is reduced, the concentration of all ions and materials is increased. When the concentration reaches saturation, scale is formed. With alkaline earth sulfates and carbonates, the saturation concentration is reduced by increasing temperature. Ion exchange (see Chap. 8) as well as chemical treatment followed by filtration can reduce the levels of sparingly soluble salts before desalination processes. However, such a treatment system may not be cost effective, economic evaluation is needed before proceeding with detailed design. The concentration factor limits for calcium sulfates in sea water are shown in figure 5-2.

5-2. Chemical treatment. Many materials, e.g., calcium salts, magnesium salts, oil and grease, total suspended solids and some organic contaminants, that are harmful to desalination processes can be reduced to acceptable levels by chemical treatment. Chemical treatment may involve any of the following: coagulation, either with or without clarification; pH adjustment, which may influence fluoride removal; or scale inhibition. When required, degasification and secondary filtration follow chemical treatment.

a. Coagulation. Non-settleable solids and some suspended materials do not precipitate because of electrical charges on the surface of the particles. If the charges on the particles can be reduced, the particles may precipitate. Chemicals that lower surface charges are lime, alum, ferric salts, and polyelectrolytes. Evaluate each chemical used in pretreatment to determine its effect on the successive steps in the desalination process. For example, calcium present in lime can cause an increase in scale formation in distillation/condensation processes; the iron present in ferric salts can cause excessive fouling in membrane desalination systems; alum is usually the best coagulant for desalination systems. Do not use pretreatment chemicals without prior operational experience and an exhaustive actual application review. The non-settleable solids and the suspended solids in conjunction with any added coagulants will be removed by either standard clarification techniques or direct filtration. Lime softening

		Suspended Solids		Immiscible Liquids	Dissolved Organic Contaminants (Non-Ionic)	Sparingly Soluble Salts
		Settleable Solids	Non-Settleable Solids			
Distillation/Condensation		P R E S E N T	1.0 NTU* (Some equipment goes higher.)	1.0 mg/l as extractable oil and grease*	These must all be evaluated on a case-by-case basis.	Saturated at the last-stage temperature (See Sample Problem A-3).
Reverse Osmosis	Spiral Wound		1.0 NTU* or 5 SDI*	1.0 mg/l as extractable oil and grease for all membranes*		Saturated in the brine stream (See Sample Problem A-3). Scale inhibitors, such as sodium hexametaphosphate, can be used to exceed saturation by two- or three-fold.
	Hollow Fine Fiber		1.0 NTU* or 5 SDI*			
	Polyaromatic Amide		3.0 SDI*			
	Cellulose Acetate		4.0 SDI*			
Electrodialysis Reversal			Less than 10 microns*	Twice saturation in the brine stream (See Sample Problem A-3). Scale inhibitors, such as sodium hexametaphosphate, are usually effective up to 4 times the saturation.		
Ion Exchange			1.0 NTU			Regeneration concentration must be adjusted, if sulfuric acid is used as regenerant.

NOTES *Based upon manufacturer's guarantee

Table 5-1. The maximum allowable contaminants in the feed water used by various desalination processes

without adequate downstream filtration and pH adjustment will lead to suspended lime particles in the feed water. Lime softening will usually remove a significant amount of fluoride and may adjust the pH to the higher levels, above 7.0, where fluoride removal is optimized. Laboratory analysis or pilot studies shall be

conducted to assure the optimal coagulation process design.

b. *pH adjustment.* The pH adjustment step of pretreatment must result in the optimal pH level for the individual desalination system. After coagulants have

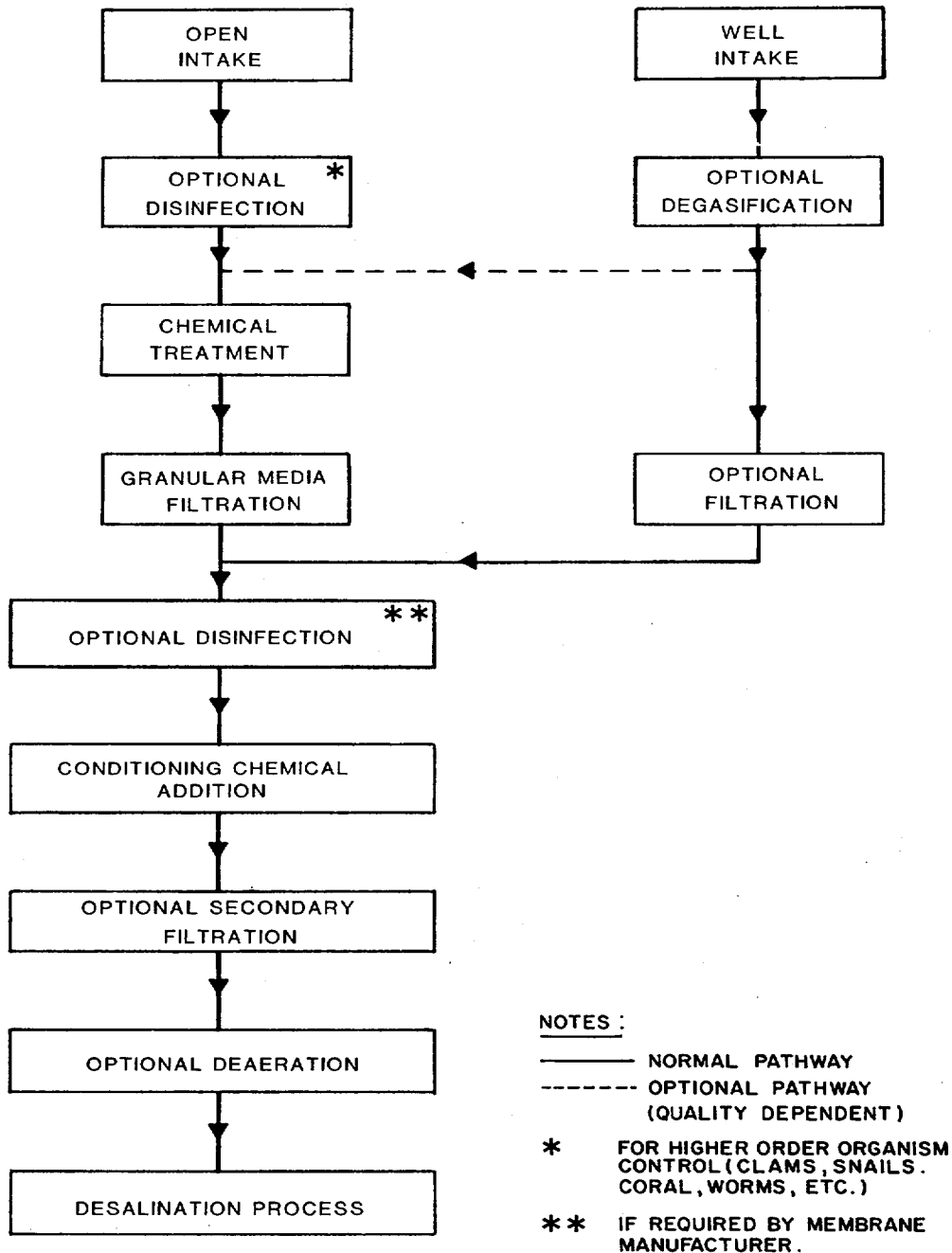

Source: U.S. Army Corps of Engineers

Figure 5-1. Pretreatment techniques.

been added, the pH is often changed significantly. In most cases, the pH must be returned to a neutral or a slightly acid level. Adjustment chemicals to lower the pH include carbon dioxide, sulfuric acid, and hydrochloric acid. Carbon dioxide should not be used for pH adjustment of lime addition systems because of the previously mentioned scaling problem associated

with lime pretreatment. Sulfuric acid should not be used for pH adjustment of systems where the resulting increase in sulfate salts can cause scaling in the desalination system. Fluoride removal will be hindered, if the pH is reduced below 7.0.

c. Scale inhibition. The formation of scale

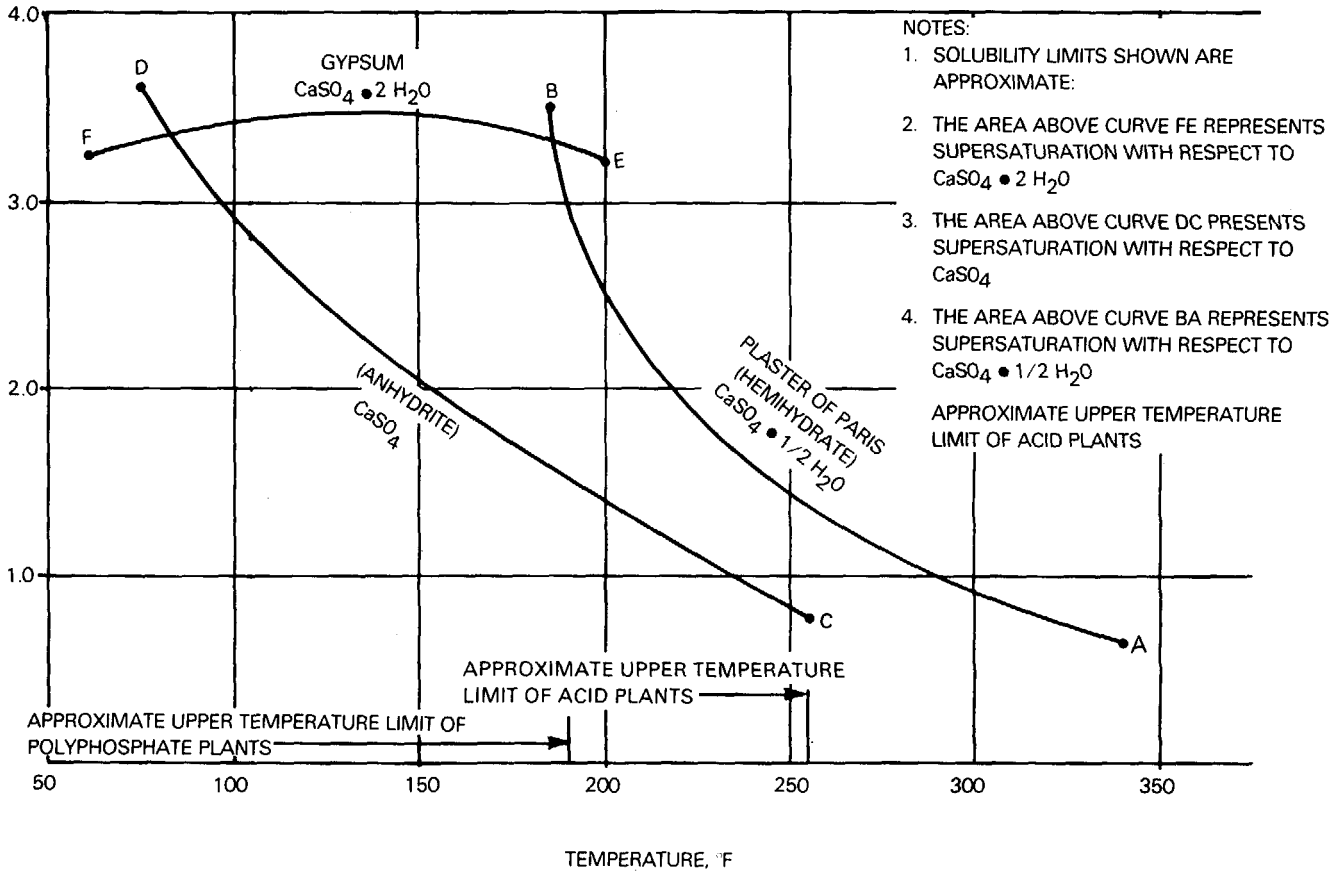

Source. American Institute of Chemical Engineers

Figure 5-2. Approximate concentration factor limits for calcium sulfate in sea water.

limits the efficiency of product water recovery during plant operation. The precipitation of calcium carbonate, magnesium hydroxide, and calcium sulfate can be prevented through the addition of scale-inhibiting chemicals. Two scale-inhibiting chemical types are commonly used: polyphosphates and polyelectrolytes. The most commonly used scale inhibitors are polyphosphate chemicals. Polyphosphates lose their effectiveness above 190 degrees Fahrenheit, which limits upper operating temperatures. To prevent the formation of scale within desalination systems, polyphosphate-based chemicals are the best general purpose additive. The most commonly used polyphosphate compound is sodium hexametaphosphate. Polyelectrolytes or organic polymers are relatively new scale inhibitors. The use of polyelectrolytes in potable water shall be in accordance with paragraph 7 of AR 420-46.

5-3. Degasification and deaeration. The removal of dissolved gases from a feed water can be accomplished in one of two ways. The dissolved gas may be stripped out with another gas, or the dissolved gas may be stripped out with water vapor. A forced draft degasification tower will remove nonatmospheric gases. This is done by blowing air up through a tower of packing. The water to be degasified is then sprinkled over the packing. When full deaeration is required to prevent the interference of oxygen and nitrogen with water vaporization or flashing, steam or water vapor must be used as the stripping gas. On high-temperature distillation systems, a steam deaerator may be used. On most distillation desalination systems, the only economical method of deaeration the water is to lower the pressure with a vacuum pump or venturi eductor or ejector to produce enough water vapor to strip away all dissolved gases. There are two basic designs for water distribution in deaerators. A design that sprays the water in the deaerator vessel will usually create the most complete deaeration. The other commonly used design involves cascading the water over trays. While the internal design of this deaerator is prone to short circuiting and incomplete deaeration, it is more compact and requires no pressure to operate the sprayers.

5-4 Filtration with granular media. Before the filtration is designed, the possibility of use of wells/infiltration galleries shall be evaluated. Filtration is necessary when the desalination process requires a low level of particulate material. Primary filtration with granular media removes particulate materials left after lime, coagulants, or other chemicals have been added to the feed waters. Single-or dual-media filtration

systems are generally used. In some cases, mixed-media filtration may be necessary. Filters may use either pressure or gravity flow methods.

a. Single-media filtration. Single-media filtration consists of one media. This media is often small-grained silica sand; however, anthracite may be used after lime and lime-soda softening. Some desalination pretreatment systems use an alternate media such as greensand to remove iron compounds. Diatomaceous earth media is not recommended for primary filtration because of its characteristic high head loss and short run times.

b. Dual-media filtration. Dual-media filtration consists of two media with different specific gravities. The difference creates a two-layer separation effect. Use silica sand or greensand for one layer; use anthracite for the other layer. The use of dual media will allow larger quantities of material to be filtered and will reduce head loss during operation. The use of two media types will provide a good coarse-of-fine filtration process for desalination facilities.

c. Mixed-media filtration. When three media are used in filters, a better coarse-to-fine filtration pattern can be constructed. High-density silica sand, garnet, and anthracite are commonly used to provide the filter bed. The different media do not stratify completely. Instead, there is a small amount of intermixing among the different layers. This gradual change in media size provides a gradient from coarse to fine and creates a media flow pattern necessary to achieve a very low silt density index.

5-5. Secondary filtration. Secondary filtration is necessary to ensure that particulate material does not pass from the pretreatment systems into a membrane desalination process. Secondary filtration is used normally as a precautionary measure. Cartridge filters are commonly used. Ultrafiltration systems can be used as a process and precautionary measure.

a. Cartridge units. The necessary protection is most easily accomplished with cartridge filters. The cartridges are replaced easily, and the filter mesh can be sized to remove from 20-micron to 0.05-micron particles. Although some cartridge filters can be backwashed, most are replaced when head loss reaches excessive levels.

b. Ultrafiltration units. The newer process for secondary filtration is ultrafiltration. New

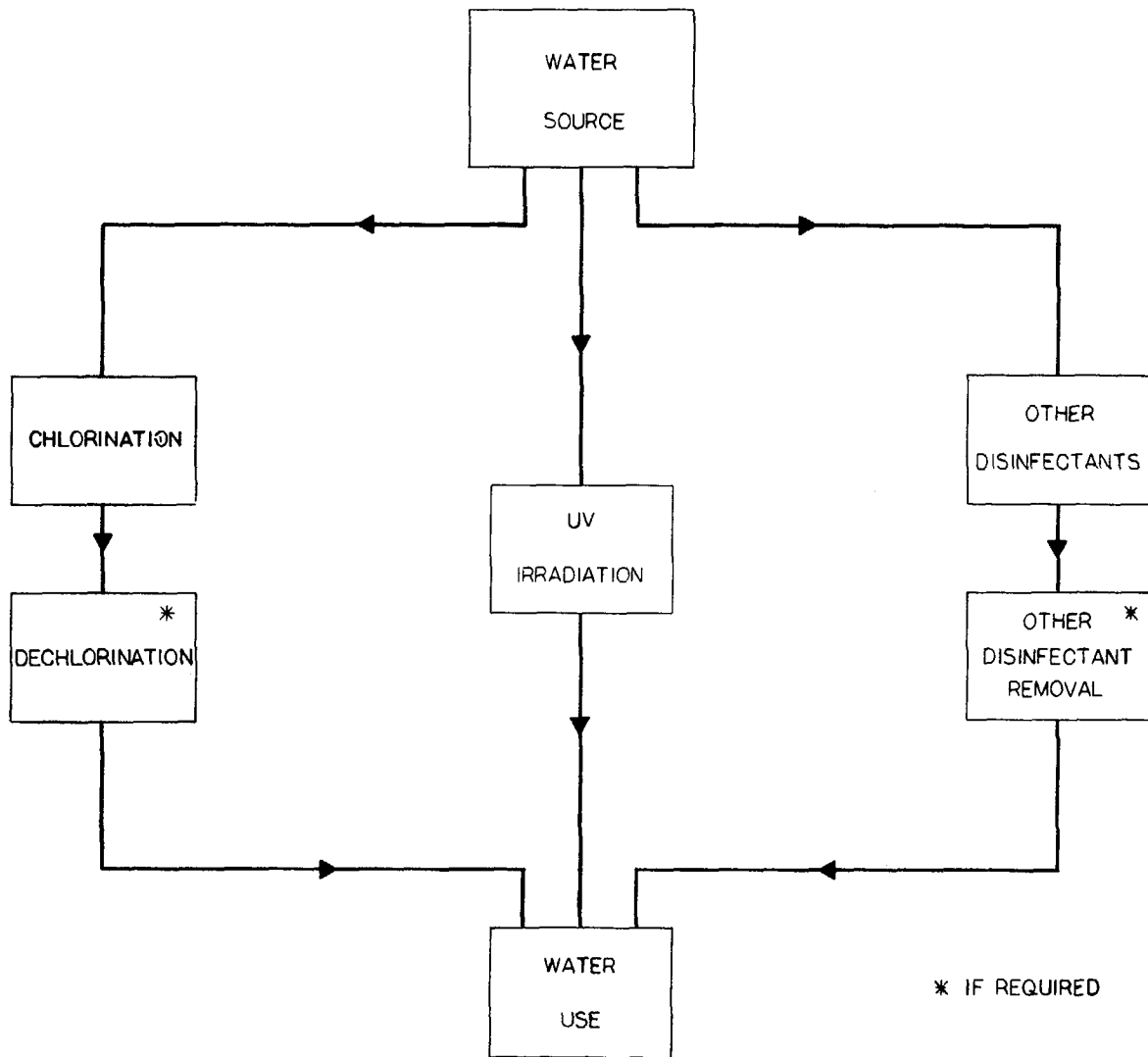

Figure 5-3. Disinfection alternatives.

materials provide 0.005-micron filtration in a stable, backwash operational unit. Some ultrafiltration units possess a salt-rejection capability, which reduces both the ultrafine particulate material and salt loading on membrane desalination processes. The ability to ensure particulate removal at 0.005-micron levels, as well as backwash capabilities, makes ultrafiltration an excellent secondary filtration technique.

5-6. Disinfection. Biological growth can seriously interfere with desalination surfaces and equipment. Cellulose acetate reverse osmosis membranes can be attacked by bacteria and require continuous disinfection application at the membrane surface. Disinfection of potable waters is required by TB MED 576 for sanitary reasons. Marine intake structures are particularly prone

to biogrowths. A strong biocide is usually needed to prevent extensive marine growths from fouling intakes, piping and storage facilities. An overview of disinfection alternatives can be found in figure 5-3. Chlorination is not advisable in the pretreatment process when organic contents are high.

a. Ultraviolet irradiation. One effective disinfection technique is ultraviolet irradiation.

Raw waters flow through a chamber where they are exposed to ultraviolet lamps. The resulting disinfection prevents bacterial destruction of cellulose acetate-based membrane systems and eliminates biofouling of polyaromatic-based membrane systems. Because polyaromatic fiber membranes are very susceptible to chemical oxidant attack, ultraviolet disinfection is the best disinfection technique for these systems.

b. Oxidants. The addition of chemical oxidants, such as chlorine, bromine, iodine, or ozone, can provide biological disinfection before membrane processes. The use of oxidants must be monitored carefully to keep the chlorine below 1.0 milligrams per liter of free chlorine residual that would even damage cellulose acetate membrane systems. For cellulose acetate membrane systems, a carefully monitored oxidant addition is the best technique for disinfection of biologically active feed waters. When biological and other organic materials are chlorinated, the resulting chlorine oxidation generates halogenated carbon compounds, such as the trihalomethane class of compounds. While the placement of chlorine disinfection upstream of coagulation or filtration will increase chlorine contact

time, which will increase the number of organisms destroyed, it will also increase trihalomethane formation. When an open intake requires optional disinfection as shown in figure 5-1 and chlorination is shown by pretreatment investigation to bring the trihalomethane content above 0.1 milligrams per liter, then no form of chlorine shall be used as a raw water disinfectant. The legal limit (per National Interim Drinking Water Regulations) for trihalomethanes in potable water effluents for communities and installations with an effective population of 10,000 or more is 0.1 milligrams per liter.

c. Dechlorination. When chlorine is used as a disinfectant, complete dechlorination of pretreated waters must occur before desalination in polyaromatic membrane systems. Dechlorination can be accomplished chemically through sulfite compound addition or passage through granular-activated carbon. Complete dechlorination and destruction of the chlorine residual by reducing compounds will ensure that chemicals do not attack these sensitive membrane systems. When a chlorinated water source must be used and complete dechlorination below 1.0 milligrams per liter as free chlorine is not possible, use distillation/condensation. When dechlorination is only economically practical to between 0.2 and 1.0 milligrams per liter as free chlorine, a cellulose acetate-based membrane system may be used.

CHAPTER 6

DISTILLATION/CONDENSATION TECHNIQUES

6-1. General. Distillation/condensation is the most common desalination process. More than 70 percent of all desalination facilities in use today employ some variation of the distillation/condensation process.

6-2. High-temperature distillation. High-temperature distillation facilities that operate at temperatures greater than 205 degrees Fahrenheit are the most prevalent desalination facilities in the world today. There are three methods of vaporization: submerged tube vaporization; flash vaporization; and thin-film vaporization. These methods are illustrated in figure 6-1. Submerged tube vaporization is the least efficient vaporization technique, but it allows for easy maintenance. This type of vaporization system is most often used in exhaust gas waste heat recovery distillation systems. The flash vaporization technique is presently the most common technique in existing distillation units. The impact of sprayed hot brine within the evaporator unit causes both erosion and corrosion of most metals. Using a thin-film sprayvaporization process, the raw water is introduced at slightly less than atmospheric pressure through an orifice onto heat exchanger tubes for immediate vaporization. The corrosive environment is reduced from the flash vaporization system, but scaling can occur on the heat transfer surfaces. These vaporization techniques are used in the two major high-temperature distillation processes, multiple-effect (ME) evaporation, and multistage flash (MSF) evaporation.

a. Multiple-effect evaporation units. To maximize thermal energy efficiency within a distillation/condensation system, several units or effects are used. The heat from the condensation step of one effect is used to supply vaporization heat for the following effect. The next effect is a slightly lowered pressure and temperature. This gradual reduction by heat transfer results in a much greater yield of product water from a given quantity of thermal energy. A typical multiple-effect evaporation unit is shown in figure 6-2.

b. Multistage flash-evaporation units. Distillation technology was advanced through the development of multistage flash evaporation units. Stages of flash evaporation are operated using heat from an external source. Pressure is reduced gradually in each successive stage to continue flash operation at successively lower temperatures and pressures. Because scaling is not a serious problem, this design has become the most prevalent distillation process. A typical multistage flash-evaporation unit is shown in figure 6-3. Although internal scaling is not a great

problem, corrosion of flash-evaporation units is of concern.

6-3. Low-temperature distillation. Distillation/condensation facilities that operate at temperatures less than 205 degrees Fahrenheit are low-temperature units. In situations where waste heat is plentiful, low-temperature waste-heat-recovery evaporation units are used. A waste-heat-recovery unit is shown in figure 6-4. For onshore application, low-pressure waste steam from power generation facilities can provide the necessary thermal energy for desalination systems. The most recent developments in distillation/condensation technology involve the use of waste heat or lowpressure steam with evaporation units and a mechanical vapor compression system. Multiple stages then derive the maximum vapor and product water production from the system.

6-4. Mechanical distillation. The use of mechanical methods for vapor production and heat transfer can result in a highly efficient desalination system. These systems operate at temperatures less than atmospheric boiling point and use a variety of methods to vaporize raw waters. These mechanical processes commonly use multiple effects to maximize the efficiency of the applied mechanical energy.

a. Vapor compression. The technique of vapor compression uses a mechanical energy source, such as an engine or electric motor, to power a compression turbine. This turbine draws vapor from the distillation vessel and compresses it, which raises the temperature of the exhaust vapor. The vapor is then passed over a heat exchanging condenser, where it returns to the liquid state as product water. The heat removed during condensation is returned to the raw water to assist in the production of more vapor. The more recent vapor-compression multiple-effect units produce a concentrated brine byproduct that has had its excess heat reduced by the multiple effects.

b. Waste heat. Adding waste heat to vapor compression systems results in a highly efficient

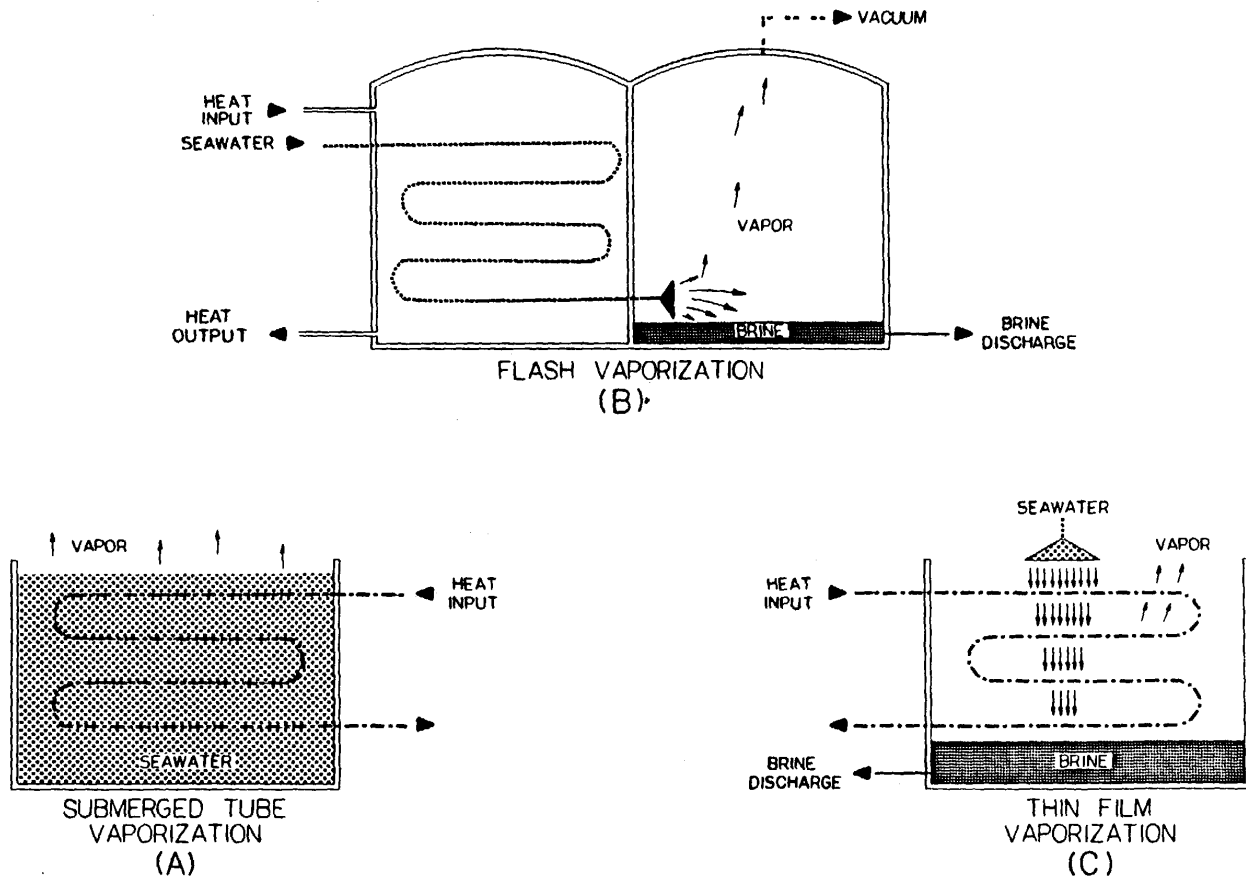

Figure 6-1. Three methods of vaporization.

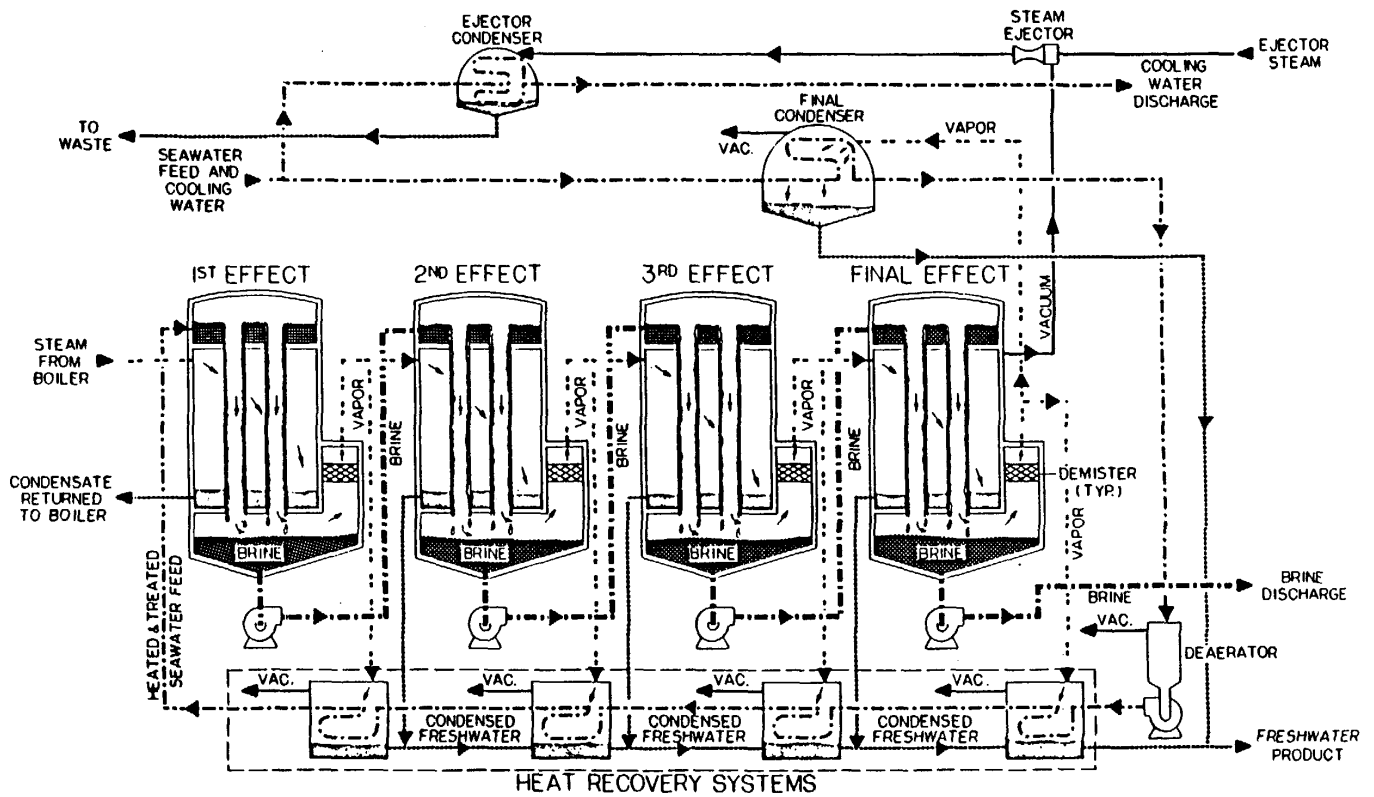

Figure 6-2. Multiple-effect vertical-tube evaporation process.

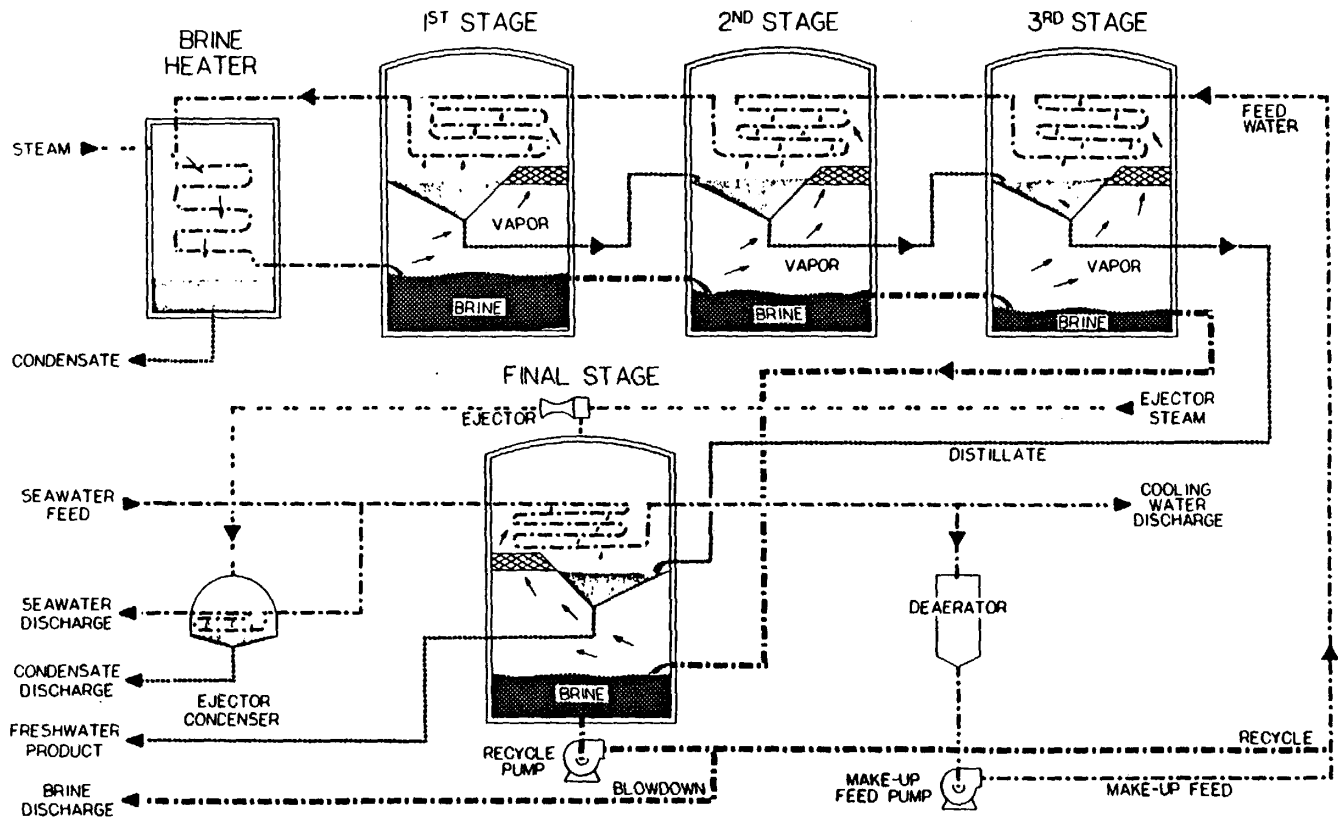

Figure 6-3. Multistage flash distillation facility.

distillation/condensation process. These systems are designed to maximize the production of product water with minimal energy input. A typical vapor-compression multiple-effect system is shown in figure 6-5.

The advantages of this type of system include a lower energy demand than high-temperature distillation, less corrosion due to possible use of thermoplastic materials, and lower operational temperatures.

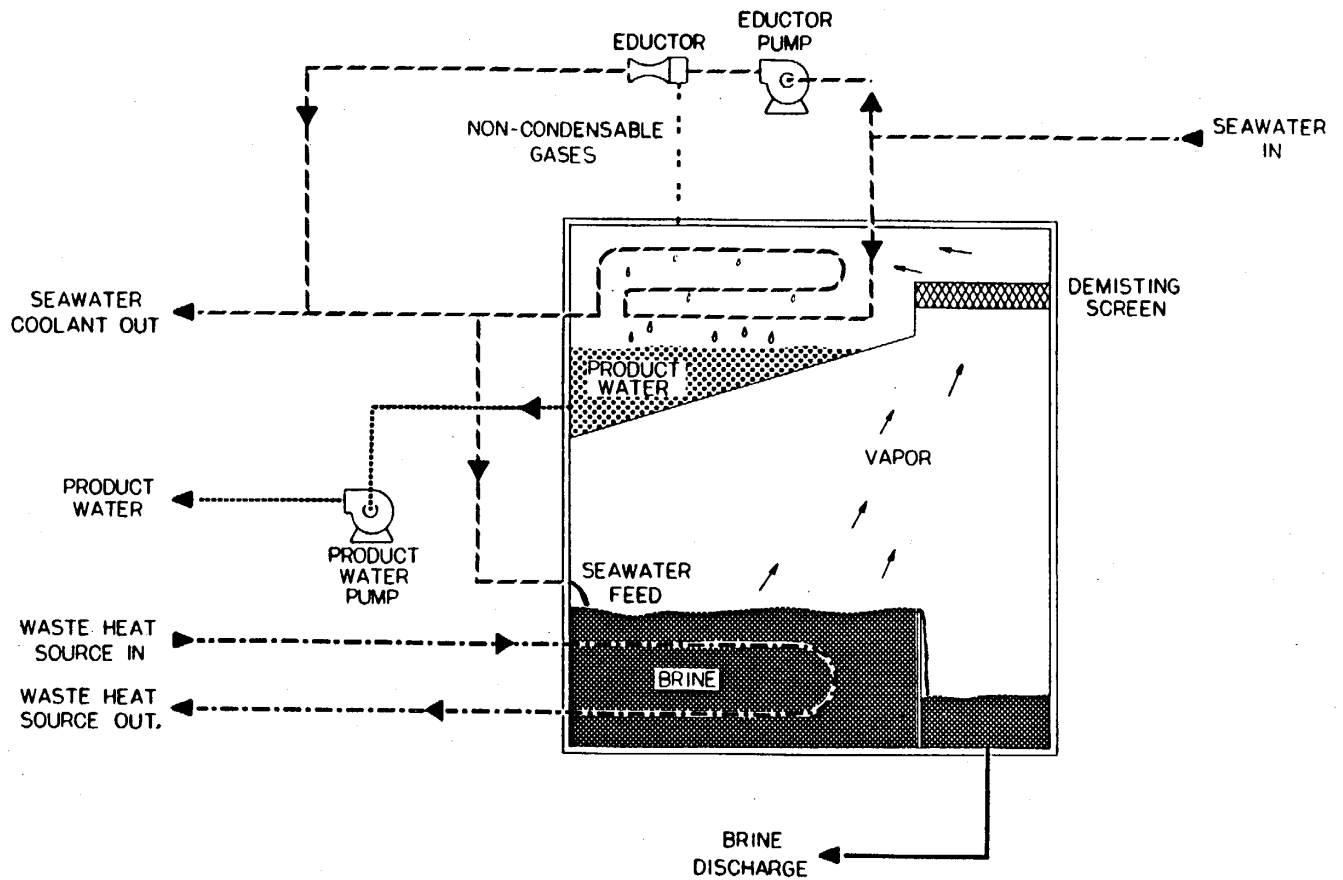

Figure 6-4. Waste heat recovery evaporation process.

Continued: 11C, Army, Corps of Engineers

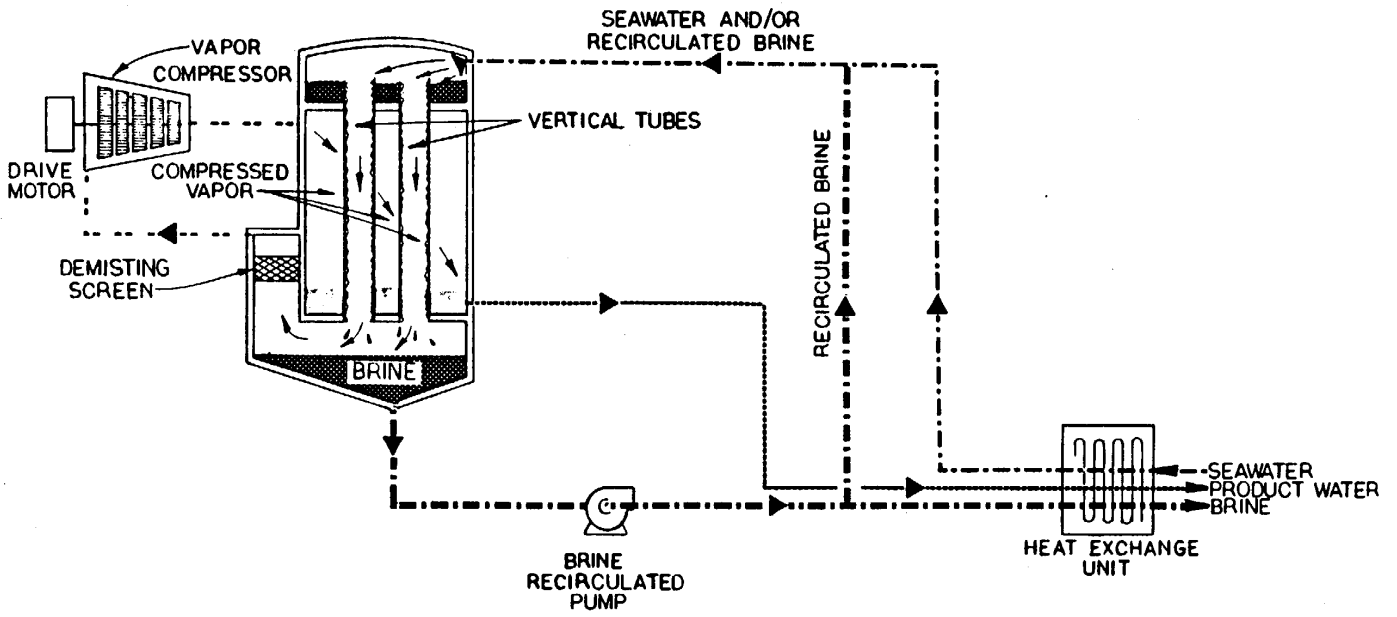

Figure 6-5. Vapor-compression vertical-tube distillation system.

6-5. Thermal discharge. A problem resulting from all distillation/condensation facilities is thermal discharge of liquids. Older high temperature facilities produce brine at very high temperatures. Cooling towers, heat exchangers, or similar equipment must be designed into the process to handle the thermal discharge from distillation/condensation facilities. More sophisticated desalination units employ a system of heat exchange devices that use the raw feed water to cool the brine and reclaim this waste heat to help provide thermal energy for system operation.

6-6. Design analysis. When it is necessary to review several water distillation/condensation designs, standard dimensionless analysis will be used for design comparison. If dimensionless correlations for particular aspects of design do not exist, a bench- or pilot-scale study should be done.

6-7. Materials of construction. The corrosive nature of high-temperature brines, acid pretreatments, and chemical scaling can cause plant failure. Presently, the only acceptable construction materials for wetted surfaces in high-temperature systems are an austenitic stainless steel, such as AISI Type 316L or titanium. Anodized aluminum and many thermoplastic materials are acceptable for use in low-temperature systems.

6-8. Distillation/condensation system design . Pursuant to finalized site and process selection, one distillation/condensation system will usually be chosen. When the process selection does not yield a single process, then designs must be prepared for more than one process.

a. Identification of work. When the base site has been selected and a schedule for construction has been prepared, this information will be made available to the water treatment engineer. The identification of the location and the time schedule will be considered in the design; this includes the date the system must be online. The minimum number and minimum size of the modules will be determined. Any restrictions that storage will place on maximum allowable downtime will also be determined. With distillation/ condensation systems, the design must address the maximum allowable total dissolved solids and, where applicable, the minimum allowable rejection of distillable material. Distillable material is defined as nonaqueous, volatile water contaminants.

b. Existing or planned facilities. Distillation/condensation systems design must include availability of energy information. See sample problem A-8. Alternative steam sources considered in the design must include steam temperature, steam pressure, and available quantity of steam. The design must show available electrical power including voltage, amperage, phase of the available electricity, and frequency of the available electrical power.

c. Raw water information. One of two circumstances will limit the quantity of raw water consumed. Both of these limitations must be considered in the design:

- The availability of raw water may place a limitation on the raw water used in the process.
- The maximum amount of waste brine that can be economically disposed of may limit the raw water used in the process.

The principle requirement in a desalination design is an accurate projection of the chemical makeup of the worst quality water that will be used as raw feed water at the site being investigated. The design must include consideration of the maximum total dissolved solids, individual ions (see App. B), maximum amount of total suspended solids present in the feed water, maximum organic contaminant loading, and any gas or potential corrosive agent that may be in the feed water. All known or anticipated future qualities of the feed water shall be considered in the design.

d. Process design. When a distillation/condensation process has been identified as the most economical, then the design will be limited to the single process. The process design for any distillation/condensation process will include a minimum required input temperature and some maximum required heat sink temperature. Between these two temperature criteria, the process must be capable of producing the required product water quality and quantity. When a particular metallurgy is required for strategic, corrosion design, or economic reasons, this metallurgy shall be designated for all applicable parts, as well as spare parts. All required instrumentation must be included in the design. The design must show the required output water quality based on the worst raw water input chemistry and quality. The system design must be based on equipment with a history of successful water treatment system experience. The required experience history should include a minimum of 2 years of operating experience meeting water quality and system design

goals, treatment capacity, maximum allowable repair frequency and duration, and a maximum allowable ratio of experienced capital cost to repair cost.

The requirement for successful experience will limit the amount of untested innovation used at a facility.

CHAPTER 7

MEMBRANE TECHNIQUES

7-1. Electrodialysis. The ions in a water solution can be made to migrate by applying an electric field to the solution. By arranging various barriers to the flow of ions, it is possible to directly desalinate water with electricity. Such barriers are called ion-exchange membranes. Membranes that allow a reasonable flow of cations, but block or reduce the flow of anions, are called cationic-exchange membranes. Membranes that allow a reasonable flow of anions, but block or reduce the flow of cations, are called anion-exchange membranes. Membranes that pass both anions and cations are called neutral membranes.

a. Theory. In solutions containing dissolved ions, electric currents are carried by movement of the ions. Positive ions migrate in the direction of the current flow, and negative ions migrate against the current direction. When the anions are blocked by a cationic-exchange membrane, they stop and form a localized charge at the membrane face. This accumulated negative charge is neutralized by the flow of cations across the cationic membrane. This generates a concentrated solution on the side of a cationic-exchange membrane that faces the negative electrode. It also generates a dilute solution on the side of the cationic membrane that faces the positive electrode as shown in figure 7-1.

b. Electrodialysis stack. If both a cationic and anionic membrane are placed across a current flow in an electrolyte solution, the side of the cationic membrane facing the positive electrode and the side of the anionic membrane facing the negative electrode will become less saline. If the cationic membrane is closer to the negative electrode and the anionic membrane is closer to the positive electrode, the solution between the membranes will become less saline as the ions migrate in their respective directions. Any number of pairs of cationic and anionic membranes can be placed across a current-carrying solution, such that the cationic membrane is closest to the negative electrode, and the solution between will be diluted (fig. 7-1). A battery of several such membrane pairs is called an electrodialysis stack. Several variations of the standard electrodialysis stack have been developed, but none have been proven superior to this standard stack of alternating cationic- and anionic-exchange membranes to desalinate natural brackish water.

c. Electrodialysis reversal. One important improvement now used in electrodialysis installations is to reverse the polarity periodically and move the ions in the opposite direction. This returns anions across the anionic membranes and helps break up scale formed on the concentrating face of the membranes. Water will flow osmotically across both membranes from the dilute product stream to the concentrated brine stream in an electrodialysis-reversal stack. This osmotic product water loss concentrates uncharged material, such as turbidity and bacteria. This concentration effect must be considered during the design to ensure meeting water turbidity and product water bacterial count requirements. Most electrodialysis membranes are not tolerant of chlorine. When possible, water desalinated by electrodialysis reversal should be disinfected after desalination is completed. The membranes should be protected by a 10-micron cartridge filter.

7-2. Electrodialysis-reversal design. When electrodialysis reversal can be shown to be the most economical process for desalination, then only an electrodialysis-reversal system will be designed. When the process selection does not yield a specific process, then designs must be prepared for more than one process.

a. Identification of work. The design engineer will be made aware of the base site and construction schedule. The location and time schedule will be considered in the design; this includes the date the system must be online. The minimum number and minimum capacity of the modules will be determined. Any restrictions that storage will place on maximum allowable downtime will also be considered. A maximum allowable output conductivity in the product water will be determined, based on the worst possible feed water.

b. Existing on planned facilities. When electrodialysis reversal is being designed, it is essential to determine the types of available electrical power. The voltage, phase, frequency, and available amperage of all electrical power sources, planned or existing, must be considered in the design.

c. Raw water information. One of two circumstances will limit the quantity of raw water consumed. Both of these limitations must be considered in the design:

- The availability of raw water may place a limitation on the raw water used in the process.
- The maximum amount of waste brine that can be economically disposed of may limit the raw water used in the process.

The principle requirement in a desalination design is an accurate projection of the chemical makeup of the worst quality water that will ever be used as a raw feed water at the site being investigated. The design documentation must include maximum total dissolved solids, the individual ions (see App. B), the maximum amount of total suspended solids present in the feed water, and any gas or potential corrosive agent that may be in the feed water.

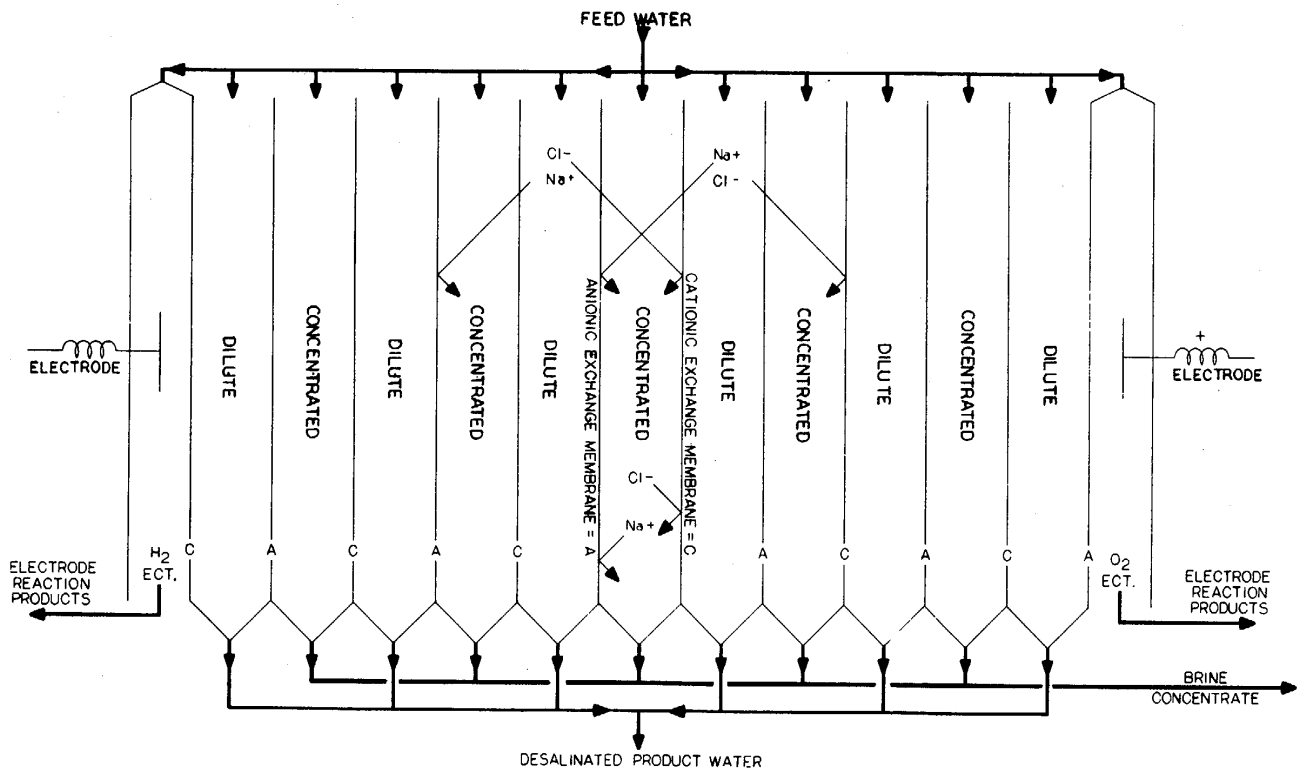

Figure 7-1. Principles of electrodesalination

d. Process specifications. When an electro-dialysis-reversal process has been identified as most economical, the design will be limited to the single process. The process design for any electro-dialysis-reversal process will include a minimum/maximum allowed product water conductivity. The design must show the required product conductivity that must be obtainable at the required product flow, based on the worst conductivity raw water. A 10-micron cartridge filter to be placed before the membranes must be included in the design. When a particular metallurgy or material is required for strategic, corrosion design, or process economic reasons, this metallurgy or material will be designated for all applicable parts and spare parts and equipment. All required instrumentation, including a voltmeter and an ammeter, for each electro-dialysis-reversal stack must be designed. The system design must be based on equipment with a history of water treatment system experience. The required experience history should include a minimum of 2 years of operating experience meeting water quality and system design goals, current operating capacity, maximum allowable repair frequency and duration, and maximum allowable ratio of experienced capital cost to repair cost. The requirement for successful experience will limit the amount of untested innovation used at a facility.

7-3. Reverse osmosis. Diffusion through materials is influenced by the nature of the diffusing material. A number of materials allow water to pass through with relative ease. Some of these materials allow only a minute passage of ionized material compared to the passage of water through them. These semipermeable materials are used for desalination. If a thin barrier or membrane is used, water can be forced through the membrane while ions are stopped by the membrane. In general, nonionized materials, such as some gases and many organics, will not be removed by these membranes. Some larger organic molecules may not pass through the membranes.

a. Osmotic pressure. When a semipermeable membrane that will pass solvent is placed between two solutions of different concentrations containing the same solvent at identical temperatures, the solvent must pass from the less concentrated to the more concentrated solution as shown in figure 7-2. This flow of solvent produces a pressure head difference. The equilibrium liquid pressure head difference is called the osmotic pressure difference of the solutions (see App A for the calculation). If these pressures are reversed, pure water will be forced from the more concentrated solution through the membrane into the less concentrated

solution, provided that the pressure differential exceeds the osmotic pressure. A typical reverse osmosis flow sheet is shown in figure 7-3.

b. Energy recovery. Reverse osmosis produces a concentrated, high-pressure brine. With reverse osmosis, the energy lost in depressurizing the brine can be returned efficiently to the feed water by mechanical methods. In small systems, consider a flow-work exchanger; in large systems, consider an energy recovery turbine.

(1) *Flow-work exchanger.* A flow-work exchanger, figure 7-4, is a simple piston driven by pressurized brine to compress the saline feed. When the piston has traveled a full stroke, the valving is changed, and the saline feed is used to expel depressurized brine. Flow-work exchangers have been under development since 1980.

(2) *Energy recovery turbines.* Several large reverse osmosis systems have been built with energy recovery turbines. These turbines can be installed to assist directly in pumping or to drive synchronous motors and generate electricity. While reverse osmosis is an energy efficient desalination process for highly saline waters, energy recovery can reduce the amount of energy used by as much as one-third.

c. Mechanical strength and packing of membranes. For containment of high pressures with thin membranes in reverse osmosis, three alternative arrangements have been developed.

(1) *Porous tubes.* Porous tubes lined with semipermeable membrane material have been developed for concentration of valuable products in industry. Such systems are no longer used for water desalination. A packing density of less than 110 square feet of surface area per cubic foot of volume makes this configuration too expensive for water production. See figure 7-5.

(2) *Spiral-wound membranes.* By using spacers it is possible to roll a membrane envelope onto a slotted product water tube as shown in figure 7-6. This reverse osmosis membrane configuration is known as the spiral-wound configuration. This arrangement allows for surface densities of greater than 250 square feet of surface area per cubic foot of volume. With the development of this spiral-wound configuration, water production from brackish water sources by reverse osmosis became economical in many applications. See figure 7-6.

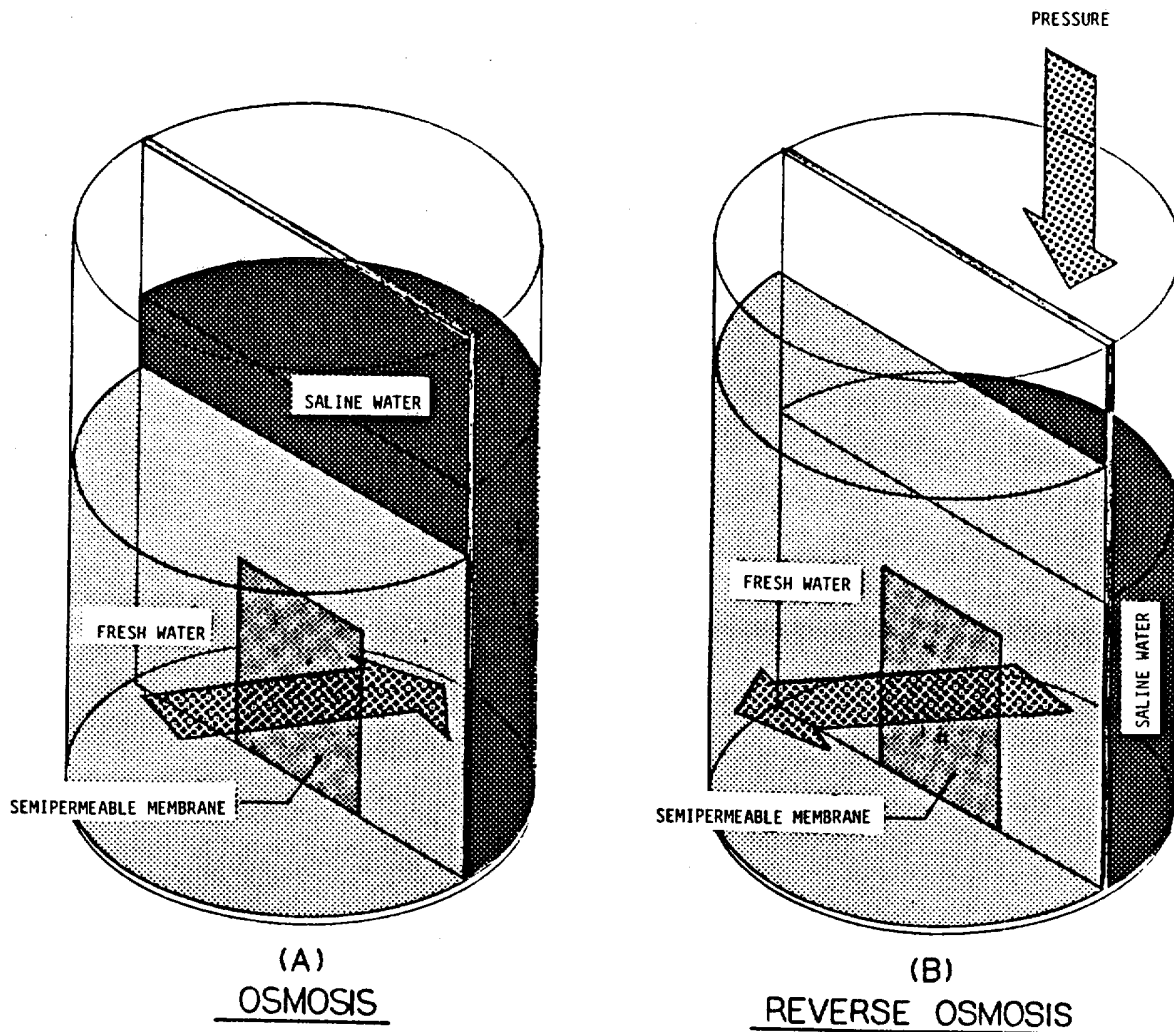

Figure 7-2. Reverse osmosis principles.

(3) *Hollow fine fibers.* A large research and development effort made it possible to coat minute hollow fibers, smaller in diameter than a human hair, with semipermeable membrane material. This reverse osmosis membrane configuration is known as the hollow fine-fiber configuration. Packing densities with hollow fine fibers have exceeded 4,900 square feet of surface area per cubic foot of volume. See figure 7-7.

d. Membrane materials. There are a number of successful reverse osmosis membrane materials. Currently, two principal types of membrane materials are being used: cellulose acetate and polyaromatic amide. Both materials are destroyed by dehydration of the membranes. To avoid dehydration, product water must be supplied to allow osmotic water to flow back through the membranes in order to dilute the feed water to approximate product water concentrations.

If product water is not supplied, then the osmotic suction, if the feed water side of the membrane is depressurized, will draw air back into the membranes and dehydrate them. Usually, the required volume of product water is supplied by a suck-back tank, which maintains a minimum volume and back pressure on the reverse osmosis membranes.

(1) *Cellulose acetates.* This material suffers from slow chemical decomposition through a process called hydrolysis. The use of acids to prevent scaling increases the rate of this form of membrane decay. Cellulose acetates are also biodegradable and must be protected from bacterial attack. One of the important advantages of cellulose acetate is its resistance to attack by chlorine.

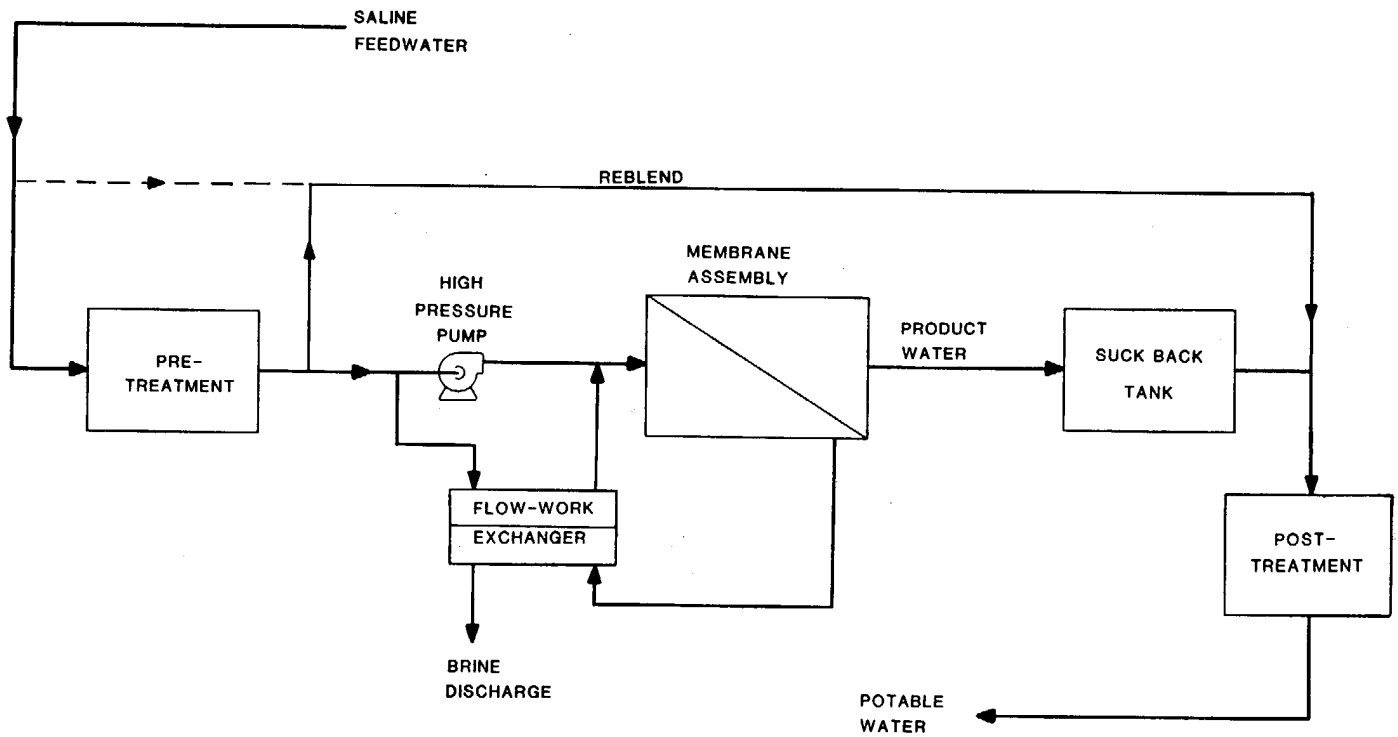

Figure 7-3. Reverse osmosis desalination system.

Most cellulose acetate membranes can be used with feed waters containing less than 1 milligram per liter of residual chlorine, which will protect the membranes from biological attack.

(2) *Polyaromatic amides*. These membranes are stable, biologically and chemically. Despite this

chemical stability, these membranes cannot tolerate any residual oxidant. If chlorination is required to reduce the amount of biological suspended solids, then dechlorination must be complete if polyaromatic amide membranes are used.

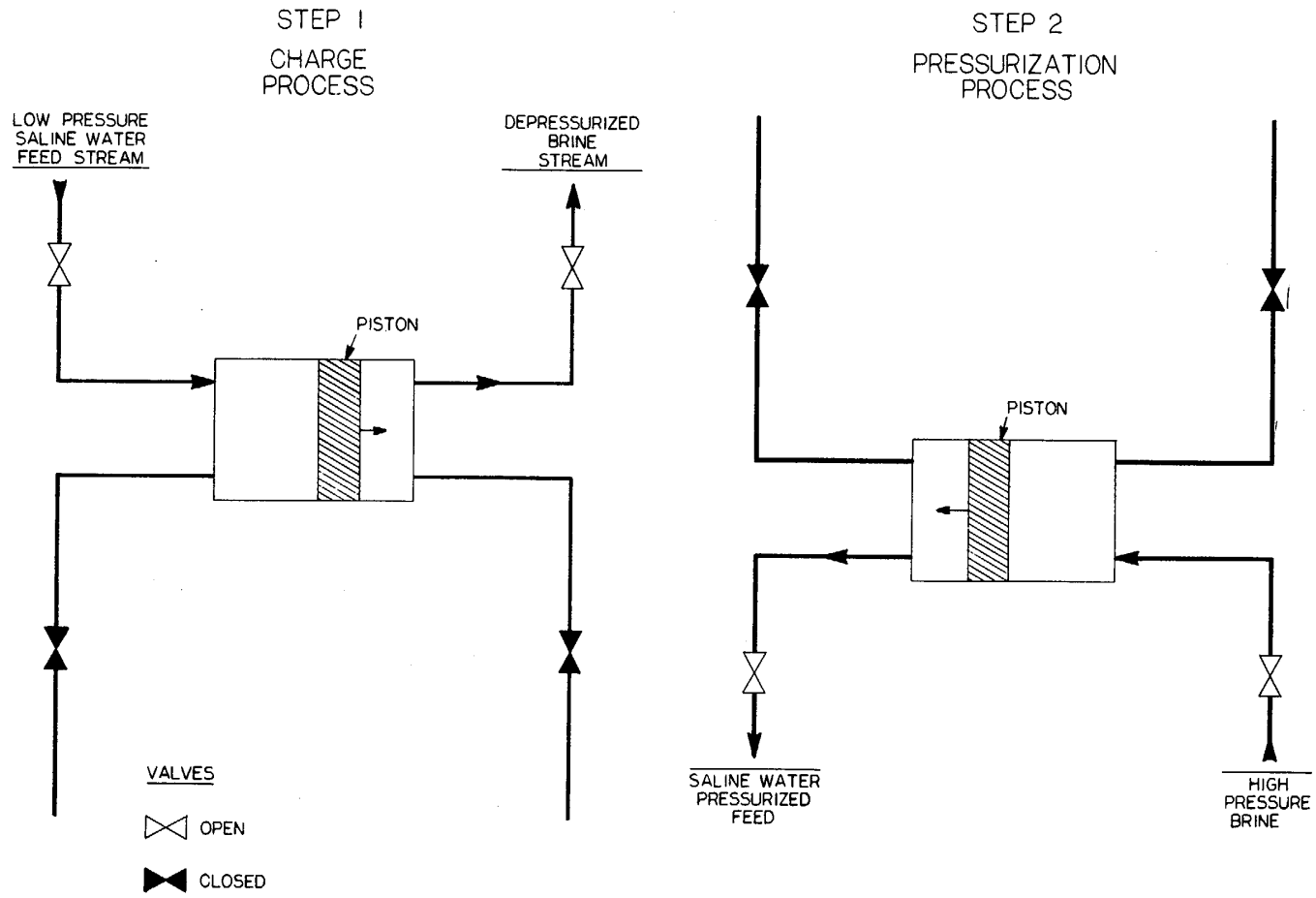

Figure 7-4. Flow-work exchanger principles.

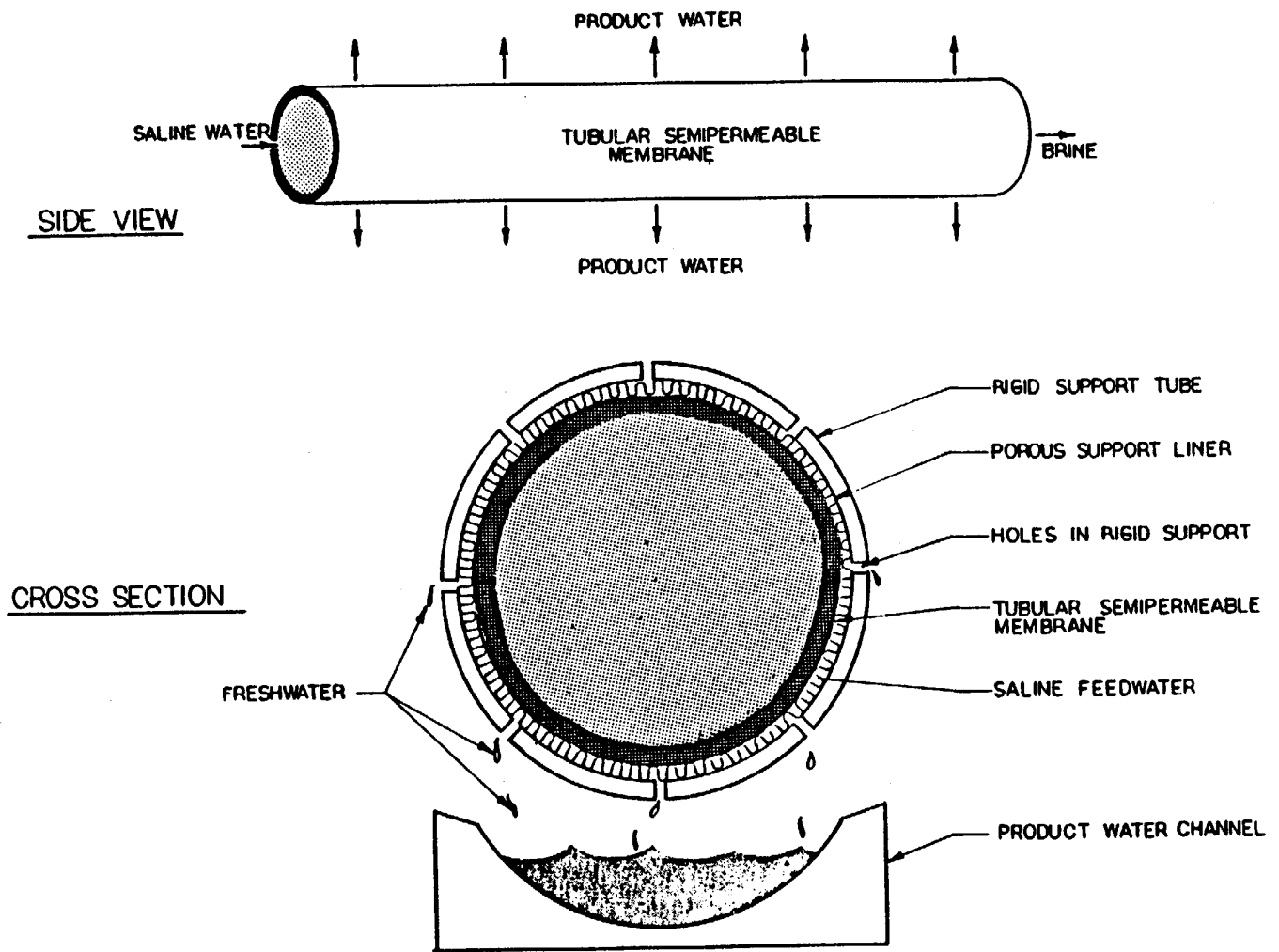

Figure 7-5. Construction of a tubular reverse osmosis membrane.

7-4. Reverse osmosis membrane staging configurations. Two kinds of membrane staging are commonly used in reverse osmosis desalination plants: product staging and reject staging. Reject staging is used to treat waters with low salinity, so that most of the raw feed water will eventually be recovered as product water. Product staging is used to treat highly saline

waters, whose product water salinity cannot be reduced to the required concentration by a single pass through the membrane under consideration. Banking is the term usually used for parallel arrangement of a number of membrane modules operating from the discharge of a single pump.

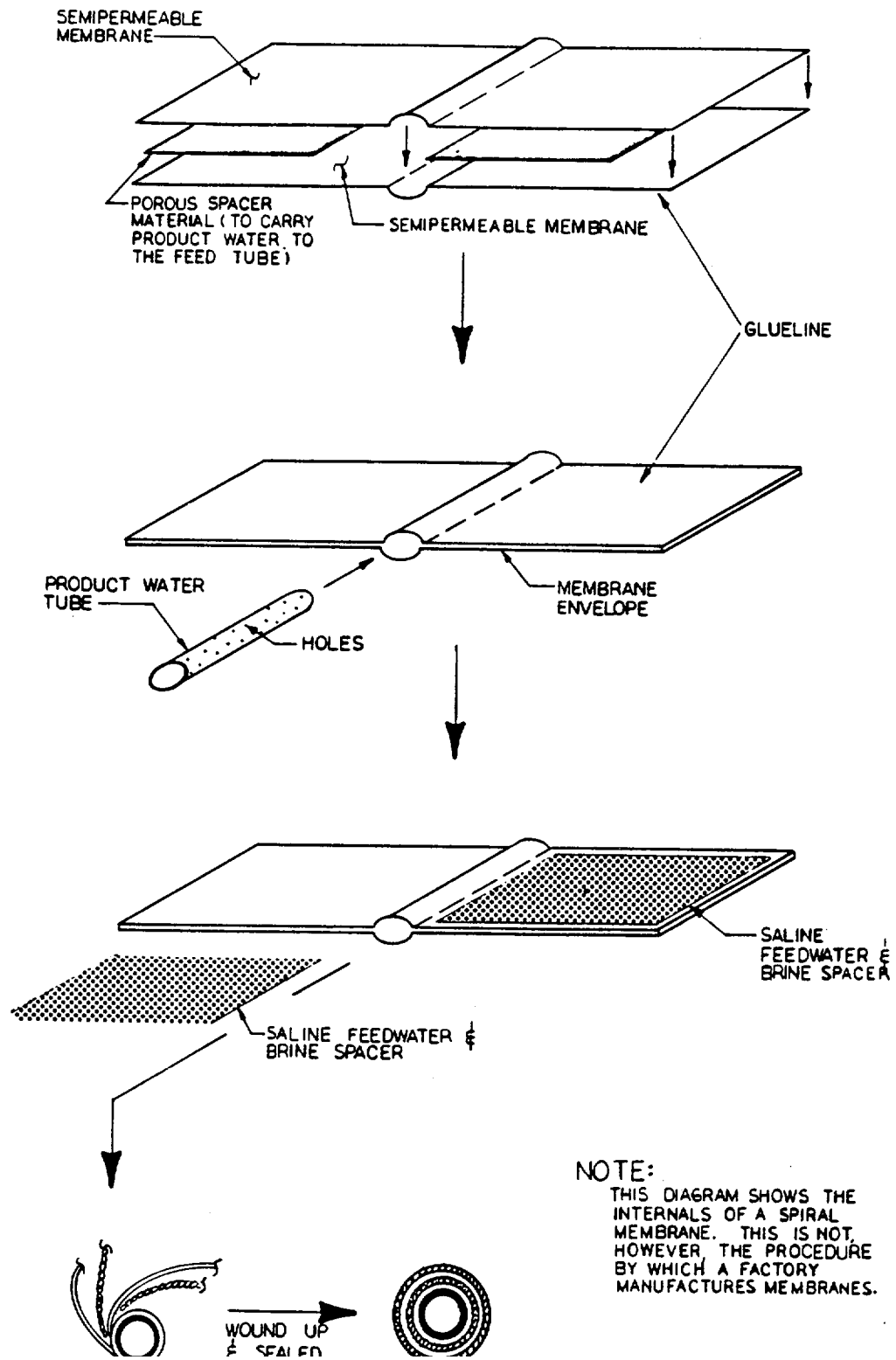

Figure 7-6. Internal construction of a spiral-wound membrane.

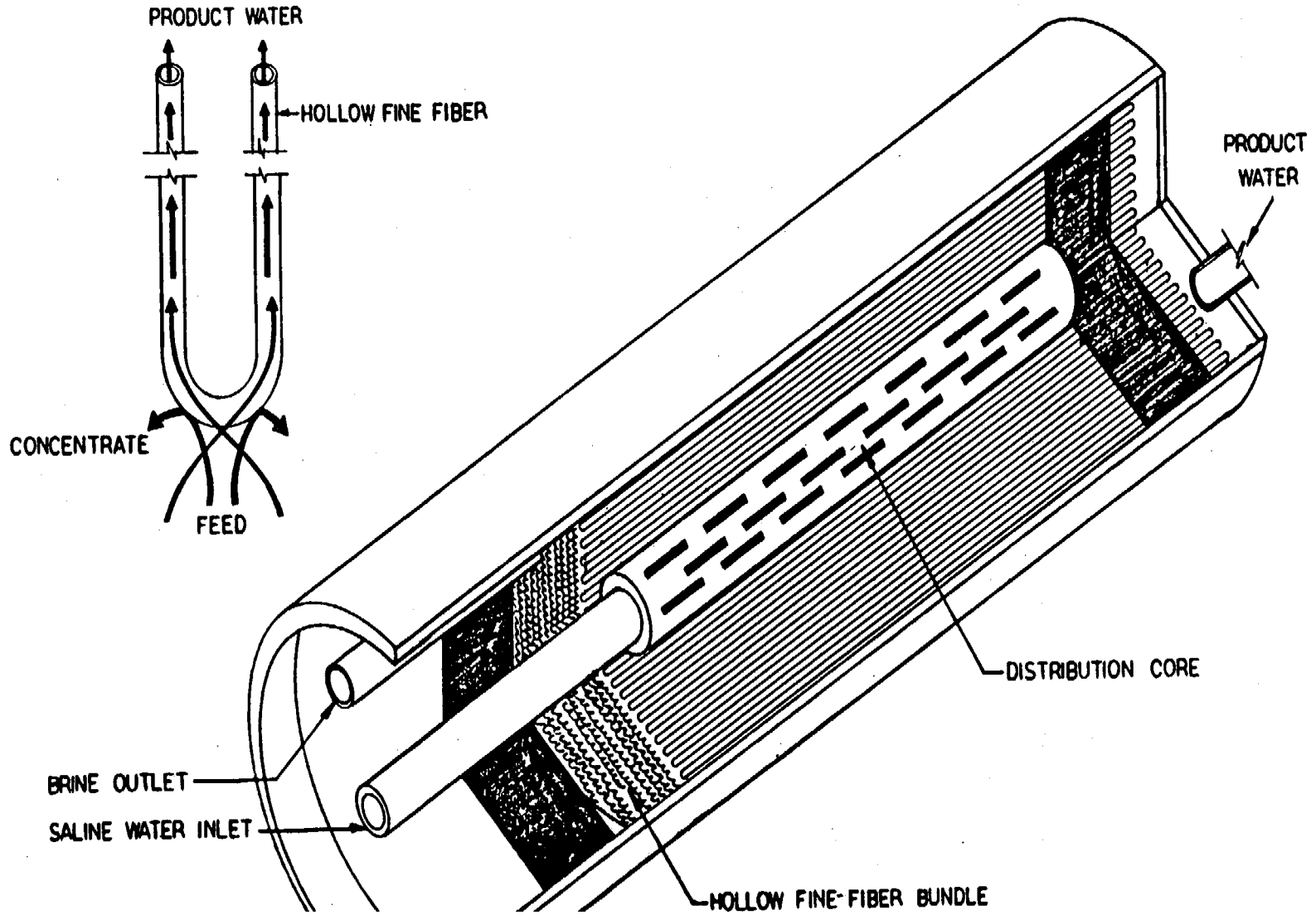

Figure 7-7. Internal construction of a hollow fine-fiber reverse osmosis membrane module.

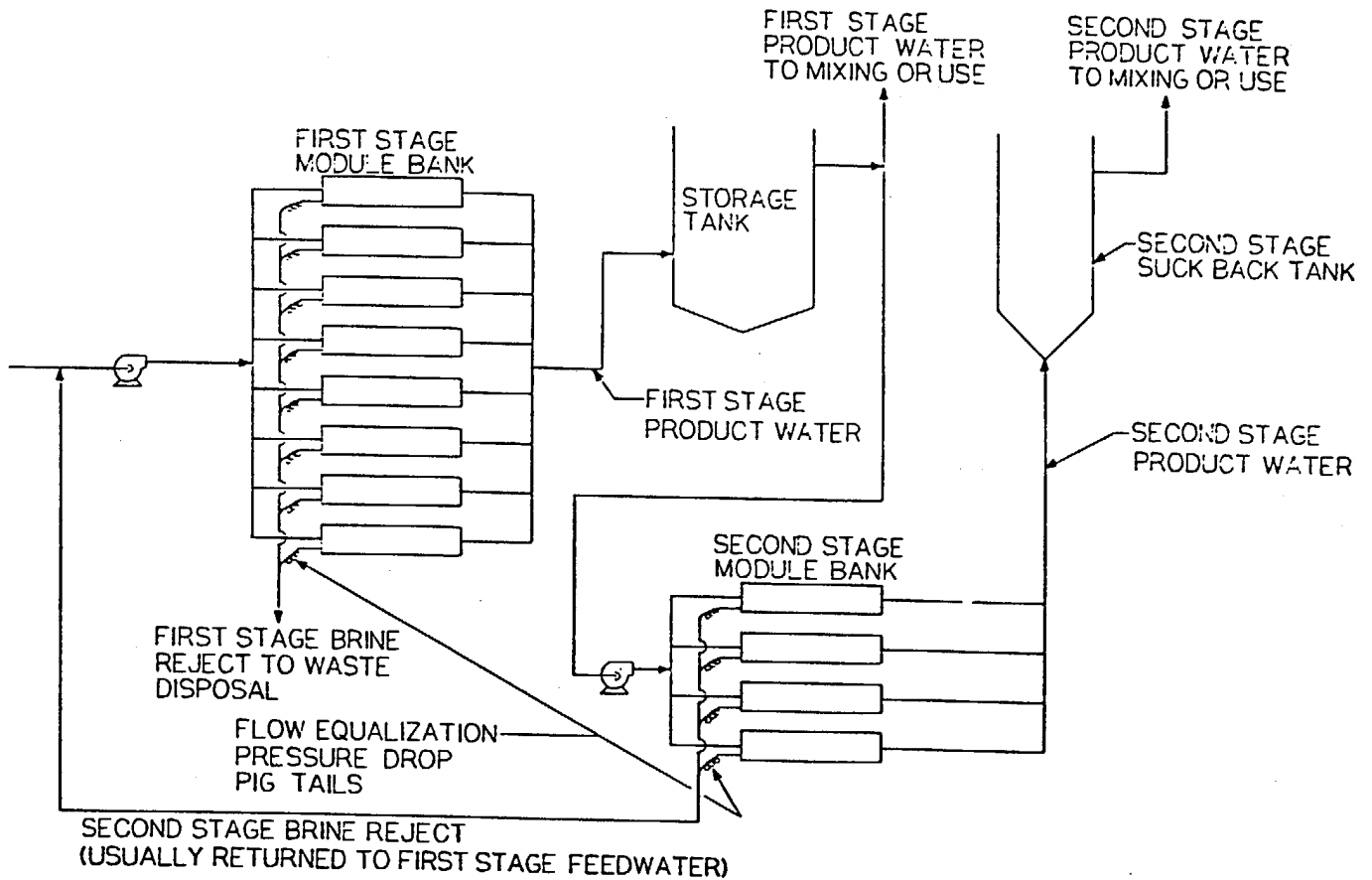

Figure 7-8. Reverse osmosis product staging.

Banking of membranes usually require a flow restraint on the brine reject of each module in the bank. A pigtail of nylon tubing is often used for this flow equalization headloss. This pressure drop maintains a balanced flow of brine out of each membrane module in the bank. Unbalanced flow can shorten the useful life of

membrane modules. While higher flow rates will tend to clean membranes, excessive flow can fatigue or fray both spiral and hollow fine-fiber membranes. Low flow rates allow the concentrated brine to stagnate, which leads to scaling and fouling of membrane surfaces.

a. *Product staging.* Product staging is true series operation of two or more reverse osmosis membrane systems, as shown in figure 7-8. Product staging is used when a single pass through one reverse osmosis membrane does not bring a constituent concentration down to specification. The second stage always requires its own pressurizing pump, taking suction from the suck-back or storage tank of the first stage reverse osmosis system. When the water produced from the second stage is significantly lower in dissolved constituents than required, the product water from the first stage may be blended with the second stage product to produce the desired water quality. When potable water and other waters with lower dissolved solids content are required, a product staging system can be used to supply the desired quality or qualities between that of the first and second stage product. Life cycle costing should be used to evaluate dual- and triple-distribution systems where product staging is required.

b. *Reject staging.* Reject staging, figure 7-9, is used when the low salinity of the raw water permits a high water-recovery ratio. Most membrane module manufacturers have a minimum allowable brine reject flow for any given membrane of their manufacture. The manufacturer's recommended maximum feed water flow rate and minimum recommended brine reject flow can be used to calculate a maximum recommended single stage recovery fraction by use of the following equation:

$$\frac{F - B}{F} = R$$

Where:

F = Maximum recommended feed flow per module

B = Minimum recommended brine reject flow per module

R = Maximum recommended recovery rate

This maximum single stage water recovery is one means of evaluating a membrane module being considered for low salinity reverse osmosis desalination. When the reject stream is still diluted enough for further concentration after the maximum recommended recovery ratio is reached, the brine can be piped directly into another membrane module for further water recovery. This is accomplished by combining the brine flow from a number of first stage modules onto a fewer number of secondary membrane modules. It is occasionally possible to further concentrate the brine on a third reject stage as shown in figure 7-9.

The design of reject staging, in order to balance the utilization of the membrane modules for optimum economical life cycle cost, is a complex activity to be performed by the membrane manufacturer or Operations Engineering Manufacturer.

c. *Combined product and reject staging.* In the desalination of highly saline waters such as seawater, product and reject staging can be effectively combined. The second stage of a product staged system can be designed as a reject staged subsystem. Any of three factors may limit reverse osmosis water recovery: osmotic pressure; sparingly soluble salts; or turbidity. Water from a primary reverse osmosis treatment system will have three properties pertaining to these limitations:

-A lower osmotic pressure than the raw feed water.

-A disproportionately reduced concentration of divalent ions.

-No turbidity.

These qualities of primary reverse osmosis product water can allow for greater water recovery from a secondary product staged reverse osmosis subsystem than is allowed by the manufacturer's maximum recommended recovery rate. When the water recovery of the second stage of a product staged system can be increased by reject staging, the secondary stage shall be reject staged. When the brine from the secondary stage of a product staged system is less concentrated than the primary stage feed water by more than 1,000 milligrams of total dissolved solids per liter, the use of dedicated desalination of this lower concentration water shall be life cycle costed. This life cycle cost for dedicated secondary stage brine desalination shall be compared with the life cycle cost of blending the secondary stage brine into the primary stage feed water.

7-5. Reverse osmosis system design. When process selection does not yield a specific membrane or even a particular process, then designs must be prepared for more than one process.

a. *Identification of work.* When a schedule and a base site have been selected, this information will be made available to the design engineer. The identification of the location and the time schedule will be considered in the design; this includes the date the system must be online. The minimum number of independently operable membrane banks and the minimum capacity of the banks must be determined. Any restrictions that storage will place on maximum allowable downtime will also be determined.

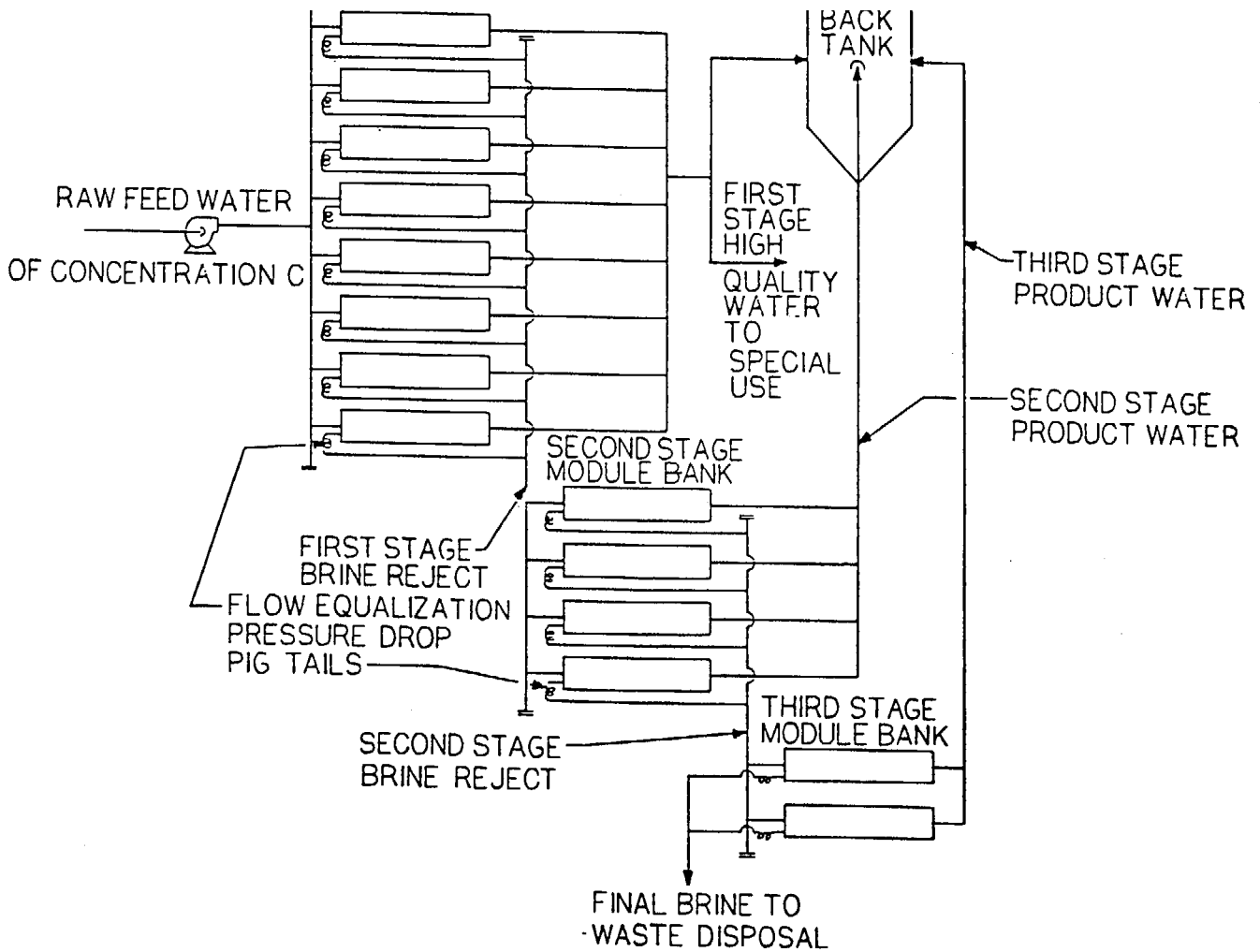

Figure 7-9. Reverse osmosis membrane reject staging.

All reverse osmosis designs will consider a minimum membrane rejection for all objectionable materials in the pretreated saline water.

b. *Existing or planned facilities.* Reverse osmosis design must include information on the available sources of mechanical energy. Electrical power is the most common energy source for conversion to mechanical pumping energy.

The phase, voltage, frequency, and amperage of all available or planned electrical power will be determined. The process design, particularly with respect to pumping and pretreatment, must be detailed clearly.

c. *Raw water information.* As with other desalination systems, one of two limitations exist on the quantity of raw water to be desalinated.

Both of these limitations must be considered in the design:

- The maximum amount of waste brine that can be economically disposed of may place a limitation on the raw water used in the process.
- Availability of the raw water may limit the raw water used in the process.

The principle requirement in a reverse osmosis design is an accurate projection of the chemical, biological, and physical makeup of the poorest quality water that will ever be used as raw feed water at the site being investigated. The design documentation must include the following:

- Maximum total dissolved solids.
- Maximum concentration of every ion that could precipitate or influence the activity coefficient of a precipitation reaction. (See App. B.)
- Maximum concentration of each ion that must be controlled in the product water.
- Concentration of both molybdate reactive and molybdate nonreactive silica.
- Maximum allowable concentration of nonionizable material.
- An oil and grease analysis to levels below 10 milligrams per liter.
- Any gas or potential corrosive agent that may be in the feed water.

d. Process design. When a particular membrane has been identified as the most economic, the design will be limited to the one membrane type. The process design for any reverse osmosis process will consider raw water quality and the required final product water quality.

A suitable tank to meet suck-back requirements will be designed for all membranes that could be damaged by dehydration. The system design must be based on equipment with a history of successful water treatment experience. The required experience should include a minimum of 2 years of experience, treatment capacity, repair frequency and duration, and a ratio of repair cost to capital cost. The requirement for successful experience will limit the amount of untested innovation used at a facility. When a particular metallurgy or material is required for strategic, corrosion design, or process economic reasons, this metallurgy will be included for all applicable parts and spare parts and equipment.

7-6. Materials of construction.

Ferric ions will cause severe problems in membrane systems. For this reason, never permit carbon steel to be in contact with the feed water being supplied to a membrane desalination plant. Use nylon or other plastics capable of maintaining the desired pressures whenever possible. Use 316L stainless steel for pump impellers and other feed-water-contact metal surfaces if hexametaphosphate is used for scale control. If no scale inhibition is necessary, use bronze for pump impellers.

CHAPTER 8 ION EXCHANGE

8-1. General. Some naturally occurring and synthetic materials can exchange one type of ion for another dissolved ion of like charge, e.g., one positive ion for another positive ion. The number of charges on the ions removed from solution must equal the number of charges on the ions exchanged from the material. The major types of synthetic ion-exchange resins that have been developed are as follows: strong acid cation resins, weak acid cation resins, strong base anion resins, and weak base anion resins. Strong acid and weak acid cation resins exchange hydrogen ions (H+) for other cations. Strong acid cation resins may also exchange monovalent sodium ions (Na+) for such divalent cations as calcium (Ca²⁺) and magnesium (Mg²⁺). Strong base anion resins exchange hydroxyl (OH-) or bicarbonate (HCO₃) ions for other anions. Weak base anion resins adsorb acidic ionic materials, such as hydrochloric acid, sulfuric acid, and carbonic acid from solutions. Once adsorbed on the weak base anion resin, the anion part of the acid may be exchanged for other anions. These exchanges occur during the service cycle when treated water is produced. When the capacities of resins have been used up or exhausted, they are regenerated with acid or base or salt to restore the resin to the original ionic state. Illustrations of the strong acid cation resin hydrogen ion-cation exchange and the strong base anion hydroxyl ion-anion exchange that occur in the complete demineralization of water are shown in figure 8-1.

8-2. Pretreatment. Ion exchange can be used as a pretreatment method in the desalination process to reduce the levels of sparingly soluble salts. A strong acid cation resin in the sodium form and a weak acid cation resin in the hydrogen form can be used. In both processes the levels of alkaline earth metal cations, such as calcium (Ca²⁺) and magnesium (Mg²⁺), are reduced. The use of the strong acid cation resin in the sodium form is called water softening, and the use of the weak acid cation resin in the hydrogen form in conjunction with a carbon dioxide degasifier is called dealkalization-softening.

a. Softening. Water softening by sodium ion exchange can be used as a pretreatment method in a desalination process. During water softening, monovalent sodium ions on the strong acid cation resin are exchanged for the divalent calcium and magnesium in the water.

Although not desalination, the exchange of sodium ions for divalent cations produces a change in the type of salinity. This change in the salinity reduces the levels of the calcium and magnesium ions, such that the concentration of other ions in the reject or blowdown stream can be increased in the desalination process with a resultant increase in water recovery. Saturation of scale-forming materials, such as calcium carbonate, calcium sulfate, and magnesium hydroxide, is still reached, but the total concentration of salts in the reject attains a higher overall level than would be possible without softening.

b. Dealkalization-softening. Desalination processes can best utilize dealkalization-softening as a pretreatment method when the raw water contains high levels of alkalinity, bicarbonate and carbonate ions, and high levels of hardness, calcium and magnesium ions. A properly operated pretreatment that utilizes a weak acid cation resin will produce water with an alkalinity level of no more than 10 parts per million (as CaCO₃) and a residual hardness approximately equal to the original raw water non-carbonate hardness.

(1) *Treatment process.* The major benefit of dealkalization-softening using carboxylic (weak acid cation) resins lies in the actual reduction of the dissolved solids content of the water. Hydrogen (H+) ions from the resin exchange with the divalent calcium and magnesium ions in the water. This exchange occurs only if the anions of weak acid salts, such as bicarbonate or carbonate ions, are present. Carbonic acid is formed when the hydrogen and bicarbonate ions react. The carbonic acid is weakly ionized and reverts to its basic constituents of carbon dioxide and water. The dissolved carbon dioxide can be removed by using degasification methods, as discussed in paragraph 5-3. The combination of the weak acid cation exchange with degasification reduces both the calcium and magnesium levels as well as the alkalinity level in the raw water.

(2) *Dealkalization-softening uses.* This pretreatment should be investigated when pH adjustment of the raw water by an acid addition is indicated for the desalination process. Weak acid resins use about 10-percent more acid than that required for pH adjustment alone and will reduce the calcium and magnesium concentration as an additional advantage.

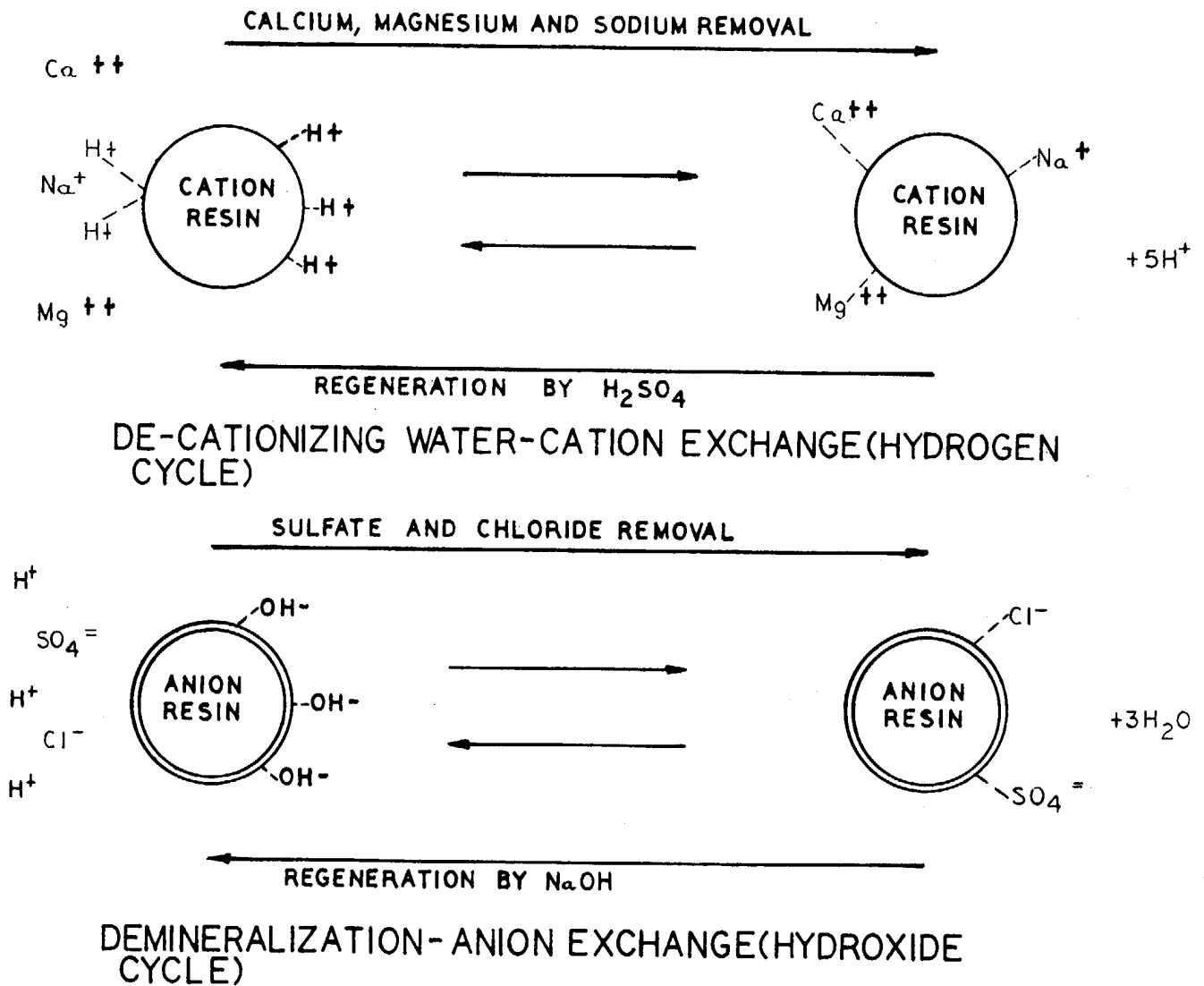

Figure 8-1. Principles of ion-exchange processes.

In brackish waters containing essentially only calcium, magnesium, and alkalinity, the use of weak acid cation resins with degasification could be considered as a possible desalination process. Since some types of weak acid cation resins also permit the efficient removal of sodium bicarbonate, the process becomes applicable as a desalination process when the raw water contains mainly sodium and alkalinity.

8-3. Desalination. Ion exchange can be used as a desalination process in the production of potable water.

a. Requirements. There are several basic requirements for the ion-exchange process to be used economically for the desalination of brackish waters.

- The ion-exchange resins should operate at high capacities.
- The ion-exchange resins should be regenerated close to the stoichiometric equivalence capacity.
- The acid and base regenerants should be low cost.
- The waste regenerants should be rinsed from the ion-exchange resins with a minimum of water, so that the capacity of the resin is not exhausted significantly.
- Regenerant waste volumes should be minimized, and unused regenerants should be recovered and reused to reduce the waste disposal volume.

b. Limitations. The use of ion exchange in the desalination of brackish water has several limitations. The volume of water treated is inversely proportional to the ionic concentration in the water. Regenerant consumption per unit volume of treated water is high and becomes higher as the salinity of the brackish water increases. The size of the ion-exchange equipment follows the same rationale—the more saline the water, the larger the ion-exchange equipment. A low salinity water, usually product water, is required for regeneration of the ion-exchange resins.

c. Treatment processes. The treatment processes employed have either been on a pilot plant scale or have been used in a limited number of full-size installations. The processes have generally utilized weak acid cation and weak base anion resins. These resins have higher capacities and require less acid and base regenerants than strong acid cation and strong base anion resins. Two ion-exchange desalination treatments that have been developed are the Desal Process and the RDI Process.

(1) *Desal process.* The Desal Process has several variations, but the main thrust of the process is the use of the weak base anion resins in the bicarbonate form.

(2) *RDI Process.* The RDI Process is a three-unit system using four different resins. The water first passes through a strong base anion resin where the strong acid anions, such as chloride, sulfate, and nitrate, are replaced with the bicarbonate ion from the resin. The water then moves through a layered ion exchange unit of weak acid cation and strong acid cation resins, where the calcium, magnesium, and sodium are removed, the bicarbonates are converted into carbonic acid, and the neutral salt leakage from the previous anion unit is converted into free mineral acidity, i.e., sulfuric, hydrochloric, and nitric acids.

Then, the water travels through a weak base anion resin, where the free mineral acidity is adsorbed but the carbonic acid passes through unaffected. The water is then degasified, which removes the dissolved carbon dioxide. The weak acid cation and strong acid cation resins are regenerated with either sulfuric or hydrochloric acid, first through the strong acid cation resin and then through the weak acid cation resin. The strong base anion and weak base anion resins are regenerated in series with sodium bicarbonate, first through the strong base anion resin and then through the weak base anion resin. The RDI Process is shown in figure 8-2.

d. Three-unit variation. In the three-unit variation, the strong acid anions in the water, such as chloride, sulfate, and nitrate, are replaced with the bicarbonate ion from a weak base anion resin in the bicarbonate form. The process then employs a weak acid cation resin that replaces the calcium, magnesium, and sodium in water with the hydrogen ion from the resin. The carbonic acid that is formed is adsorbed by a second weak base anion resin in the free-base form. When the system has exhausted its treating capability, the lead weak base anion resin is regenerated with ammonia, caustic, or lime, the weak acid cation resin is regenerated with sulfuric, hydrochloric, nitric, or sulfurous acid, and the tail-end weak base anion is not regenerated. The lead weak base anion resin is now in the free-base form and the weak acid cation resin in the hydrogen form. After its adsorption of carbonic acid in the previous service cycle, the tail-end weak base anion is in the bicarbonate form. The service flow direction is reversed for the next service cycle, with the former tail-end weak base anion in the lead position and the former lead weak base anion in the tail-end position. The direction of service flow is reversed on each succeeding service cycle after regenerating only the weak acid cation and the former lead weak base anion. This three-unit variation of the Desal Process is shown in figure 8-3, with the following sequence of operation: Service-A followed by Regeneration-B, Regeneration-B followed by Service-C, Service-C followed by Regeneration-D, Regeneration-D followed by Service-A, Service-A followed by Regeneration-B, etc., in a repeating sequence.

e. Two-unit variation. In the two-unit variation, carbon dioxide is fed to the raw water. The carbon dioxide in the water (carbonic acid) converts the weak base anion resin in the lead unit to the bicarbonate form and the strong acid anions in the water, such as chloride, sulfate, and nitrate, are replaced with the bicarbonate ion from the resin.

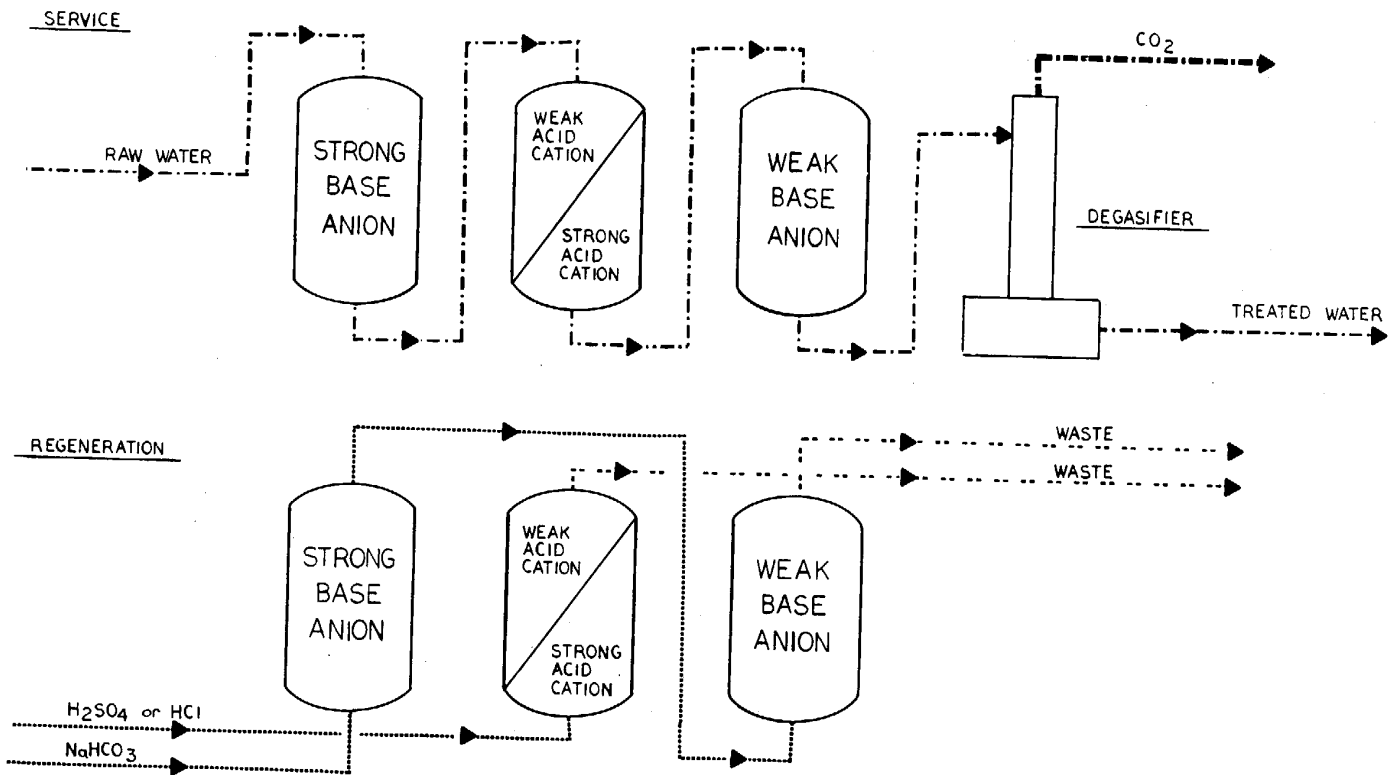

Figure 8-2. RDI Process.

The process then employs a weak acid cation resin, in the same manner as the three-unit variation, which replaces the calcium, magnesium, and sodium in the

water with the hydrogen ion from the resin. The carbonic acid or dissolved carbon dioxide that is formed is now removed by a degasifier.

Ammonia, caustic, or lime can be used to regenerate the weak base anion resin and sulfuric, hydrochloric, nitric, or sulfurous acid can be used to regenerate the weak acid cation resin. The two unit variation of the Desal Process is shown in figure 8-4.

water as pure as does ion exchange. In the production of steam, it is sometimes necessary to use water with a lower level of total dissolved solids. Ion exchange should be considered if water with less than approximately 300 milligrams per liter of total dissolved solids must be purified further.

8-4. Demineralization. No other demineralization or desalination technique can, in a single pass, produce

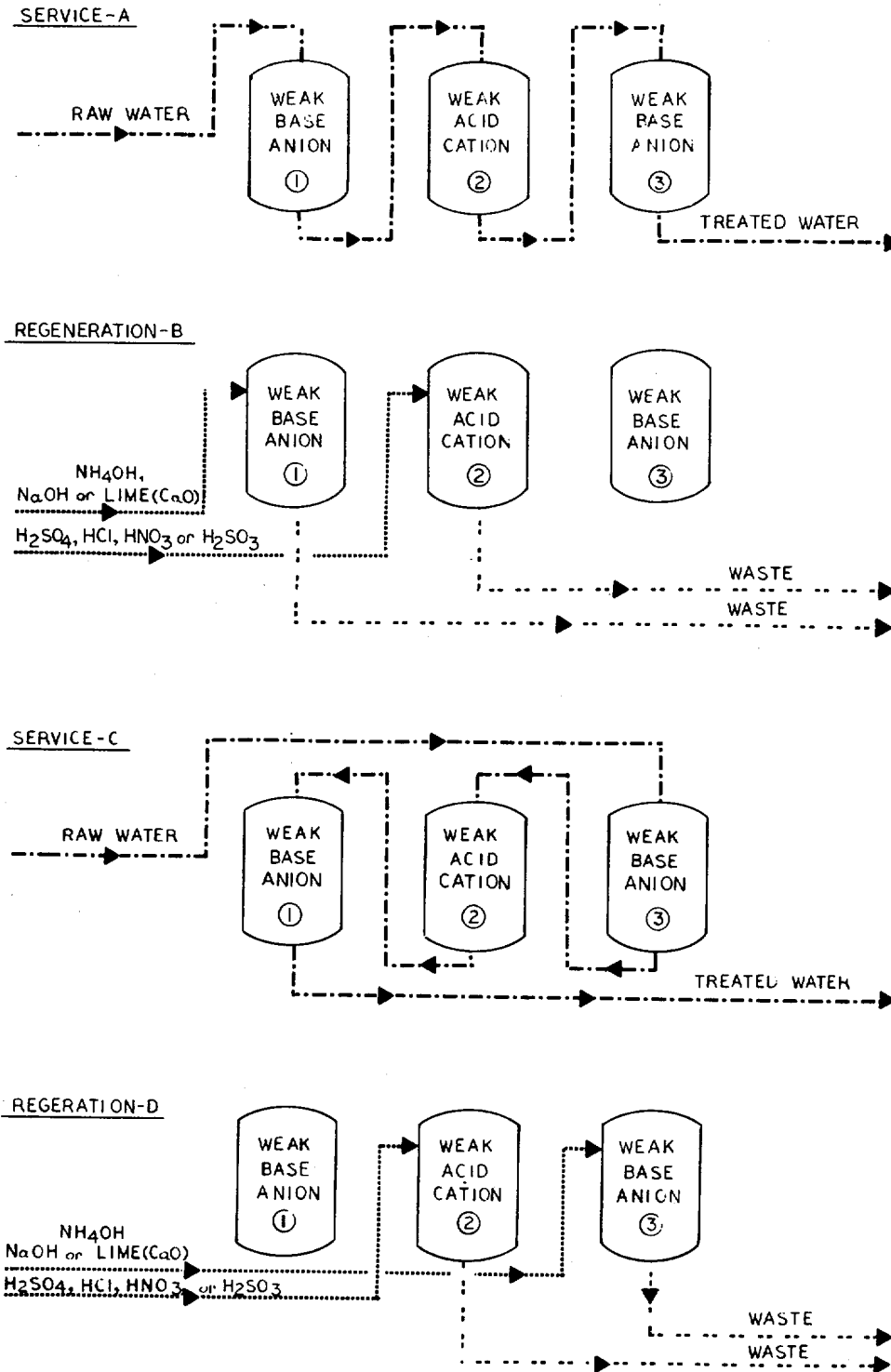

Figure 8-3. Three-unit variation Desal Process.

Source: Rohm and Haas Co.

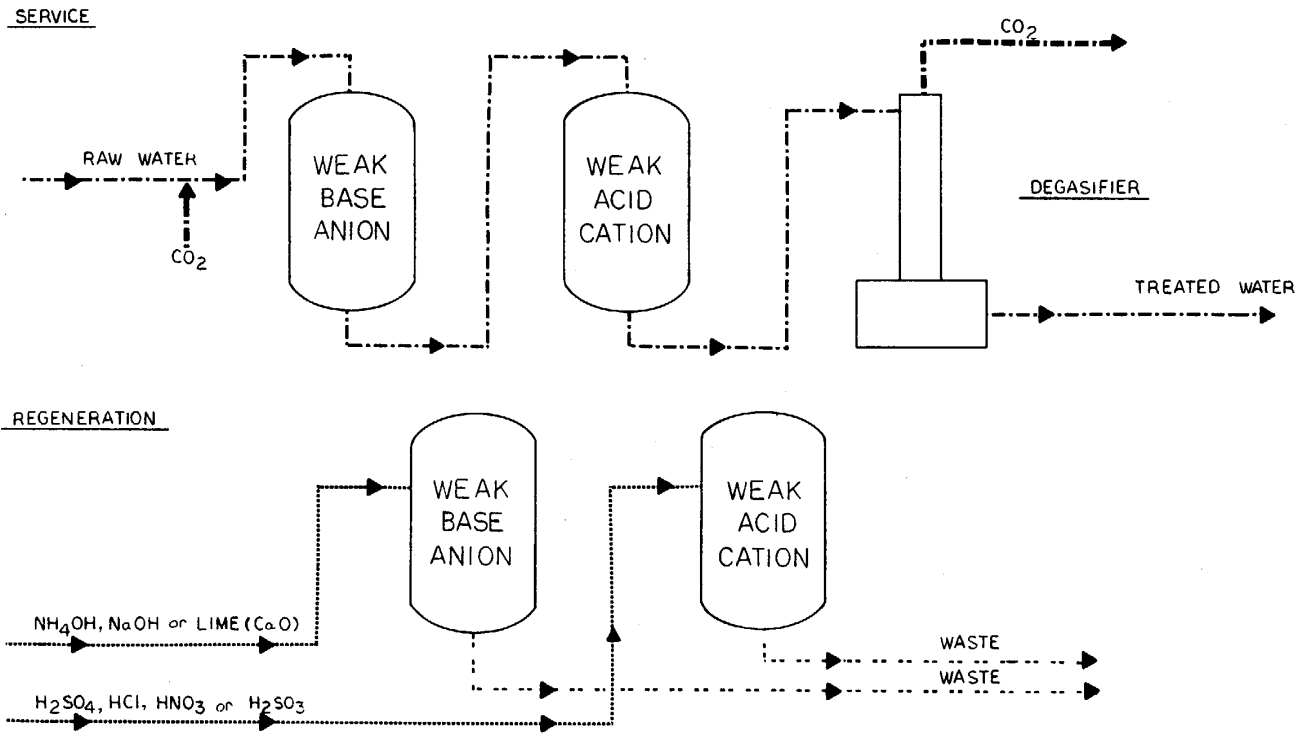

Figure 8-4. Two-unit variation Desal Process.

A typical cation-anion two-bed demineralization flow sheet is shown in figure 8-5. The cost of ion-exchange regeneration, including regeneration waste disposal, is directly related to the amount of dissolved solids to be

removed. For many small users, such as laboratories, replaceable mixed-bed ion-exchange cartridges are the most economical method used to obtain ultrapure water.

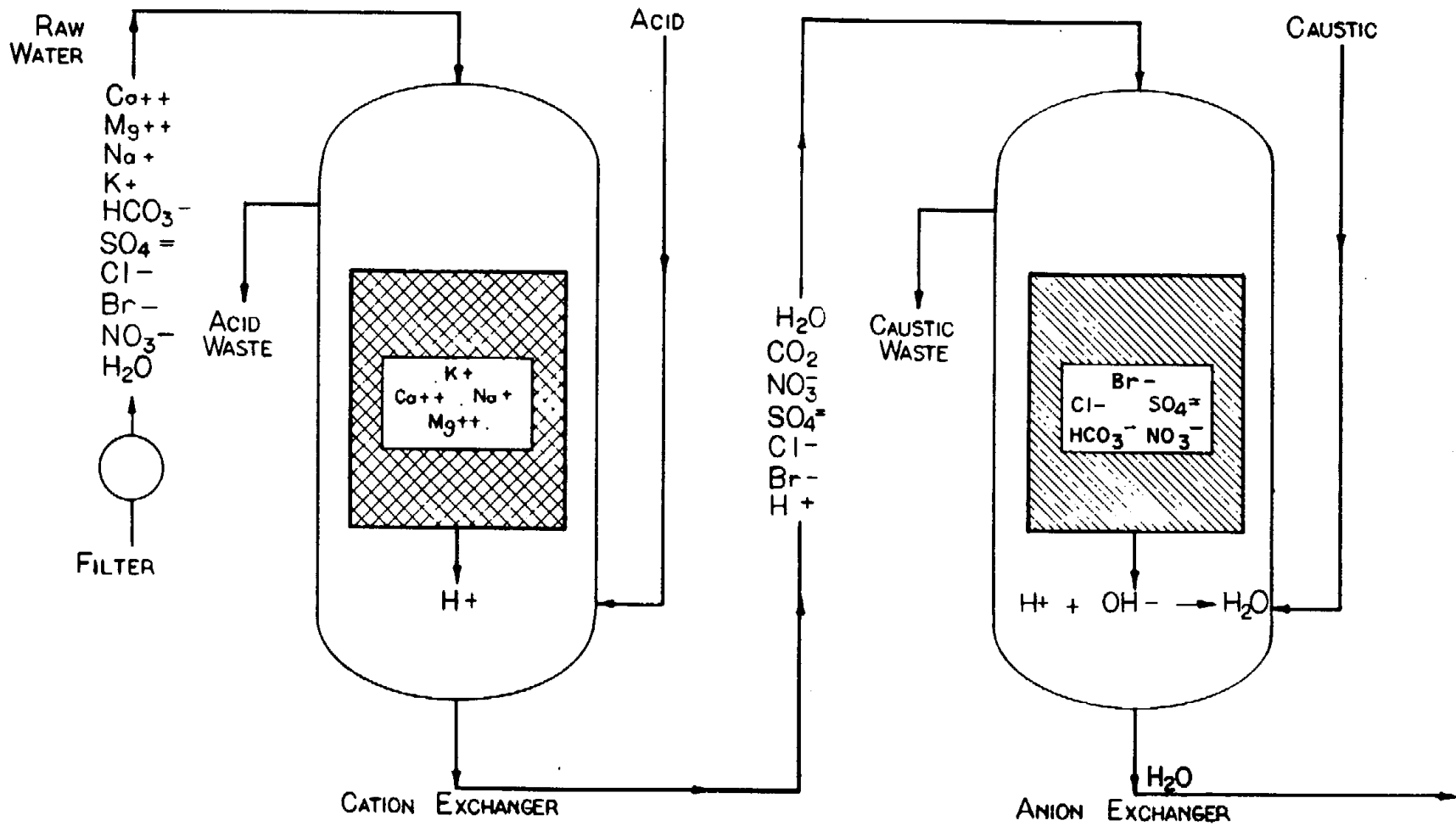

Figure 8-5. Demineralization two-bed flowsheet.

CHAPTER 9 POST-TREATMENT

9-1. General. Desalination can and most often does produce water so free of dissolved material that corrosion and potential health problems are possible. Electrodialysis reversal is an exception to this general rule. Electrodialysis reversal does not remove microorganisms.

9-2. Remineralization and aeration. Pure water is a relatively reactive chemical. When air is dissolved in extremely pure water, the resulting solution is extremely corrosive. Water without dissolved air tastes flat and objectionable. Water that contains very little hardness appears to be unhealthy for drinking purposes. Therefore, the designer of a desalination system must consider some posttreatment options, such as remineralization and aeration, in order to produce a healthful, noncorrosive, pleasant-tasting water.

9-3. Post-treatment of distilled water. The mineral content of distilled water is much lower than is considered healthy for drinking purposes. Distilled potable water should be aerated and remineralized for health, taste, and to prevent corrosion. Some radionuclides may not be removed by distillation/condensation, which may require post-treatment by ion exchange, prior to all other post-treatment methods.

a. Reaeration. Distilled potable waters will be reaerated before use. Cascade, eductor, or sprayed aeration are acceptable but must be followed by disinfection to prevent bacterial contamination.

b. Mineralization. Recent studies have indicated that the hardness of drinking water is important for human health. The Langelier Corrosion Index was developed to predict the tendency of water to deposit or dissolve calcium carbonate. Recalcification of distilled water will be performed in order to reach a positive Langelier Corrosion Index by adding lime. Fluoridation of Army potable water supplies is discussed in TB MED 576.

c. Corrosion control. Distilled water has a greater corrosion potential once it is aerated.

Any boiler feed water should bypass reaeration where possible. Corrosion should be controlled by the addition of sodium hexametaphosphate or sodium silicate, in conjunction with remineralization, prior to entry into the distribution system.

The Langelier Corrosion Index can be adjusted to a slightly positive value by pH adjustment. The adjustment of the distilled water pH should occur immediately after reaeration, prior to distribution, as airborne carbon dioxide may influence the pH.

d. Residual disinfection. Residual disinfection should be present in the active parts of the distribution system. A break-point chlorination curve is shown in figure 9-1. Chlorine disinfection of very pure water leads to a chlorine residual that is free of combined chlorine or chloramines. Chlorination of distilled water systems should occur immediately prior to the distribution system. Where it is convenient or economical, calcium hypochlorite should be used to control pH to aid in recalcification and to disinfect the distribution system. Disinfection of Army potable water supplies is discussed in TB MED 229 and TB MED 576.

e. Reblending for remineralization. One of the most cost-effective ways to remineralize distilled water is to blend a small stream of pretreated saline feed water back into the distilled product water. When bacterial contamination is sufficiently low and hardness is sufficiently high, then reblending is an acceptable means of distilled water remineralization. When reblending is practiced, boiler feed water should be removed from the system upstream of the reblend point. Saline water used for reblending must have a 30-minute chlorine contact time. This chlorinated reblend stream is an excellent method of providing the total chlorination for the distribution system. As further discussed in Chapter 10, brine can be used to electrolytically produce hypochlorite ion for disinfection.

9-4. Post-treatment of reverse osmosis product water. Unlike distilled water, reverse osmosis product water is not necessarily free of dissolved gases. If degasification is not used as a pretreatment step, the dissolved gas content of the reverse osmosis product stream will be roughly that of the feed stream.

Since divalent and trivalent ions are better eliminated by reverse osmosis than are monovalent ions, reverse osmosis product water is usually very soft and has a hardness level that is unhealthy when used as drinking water.

a. Corrosion control. As a consequence of the dissolved gas content of the reverse osmosis product water, corrosion control should occur as close as is convenient to the suck-back tank.

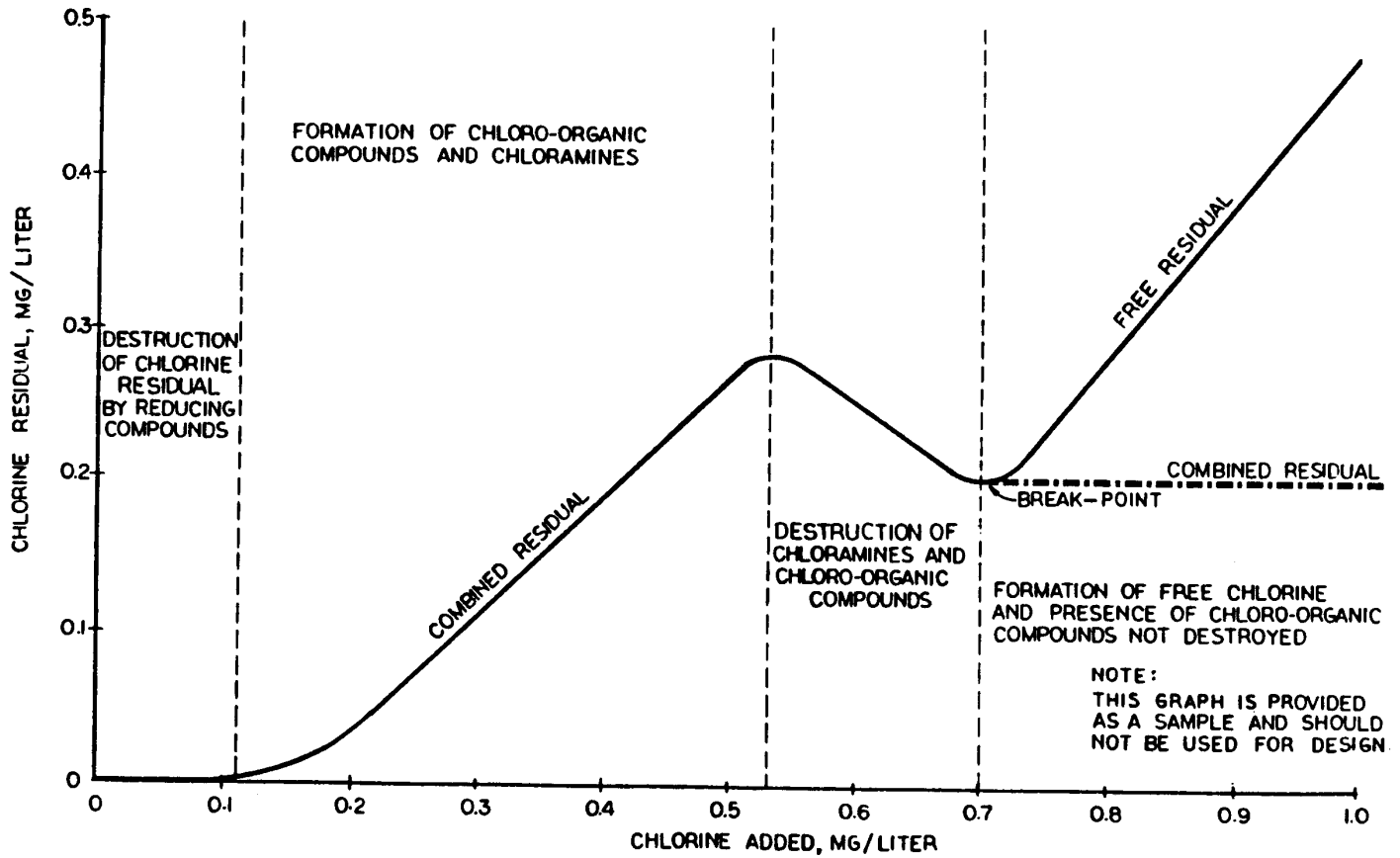

Figure 9-1. Break-point chlorination curve.

A high carbon dioxide content in reverse osmosis product water contributes to corrosion. This is true, particularly where acid is fed for scale control.

A degasification tower is used to obtain equilibrium with atmospheric carbon dioxide. Degasification should occur after remineralization. Boiler feed water or wash water should be drawn off prior to corrosion control.

To control corrosion of reverse osmosis product water, add sodium silicate or sodium hexametaphosphate. Corrosion control is affected by recalcification and Langelier Corrosion Index adjustment.

b. Reverse osmosis remineralization. Occasionally, remineralization of reverse osmosis product water is not necessary. Since reverse osmosis increases the monovalent-to-divalent ion ratio, remineralization is usually advisable. This remineralization, will contribute to the production of a pleasant tasting and healthful product water.

c. Residual disinfection. The use of calcium hypochlorite for disinfection will assist in remineralization.

d. Reblending. Reblending of pretreated saline water is an acceptable remineralization procedure for reverse osmosis product water as long as the hardness of the reblend can be shown to be healthful. All reblended water must receive a full 30-minute chlorine contact time.

9-5. Post-treatment of electro dialysis-reversal product water. Electro dialysis reversal does not remove small suspended material. The pretreatment for electro dialysis reversal should remove any material that will plug a 10-micron filter. Loosened scale and particulate matter may require postdesalination removal. Micro-organisms are not removed by electro dialysis reversal.

a. Suspended solids removal. Suspended solids removal during pretreatment is the preferred design for electro dialysis-reversal facilities. Pretreatment of suspended solids removes particulates, including micro-organisms, which are prone to blind electro dialysis-reversal membranes. This removal reduces the time between cleanings. When electro dialysis-reversal product water turbidity cannot be controlled economically by pretreatment, then an attempt will be made to eliminate all pretreatment suspended solids

control. If this is feasible, suspended solids control will be a post-treatment process at the electro dialysis-reversal facility. When it is impossible to centralize all turbidity control, and electro dialysis reversal is still shown to be economical, both pretreatment and post-treatment suspended solids control shall be designed. At high-current densities, electro dialysis reversal will soften water by the selective removal of multivalent ions. At low-current densities, electro dialysis reversal can be used to selectively remove monovalent ions. This selective removal of monovalent ions at low-current densities can be economical for fluoride or other exotic ion removal or control where total dissolved solids and other ions are not a problem.

b. Remineralization. Remineralization of electro dialysis-reversal product water is seldom necessary. When recalcification is deemed desirable, it is generally best to make provisions for adding calcium carbonate.

c. Residual disinfection. Disinfection chlorination of electro dialysis-reversal product water should occur as soon as possible after electro dialysis-reversal desalination. Electro dialysis reversal will remove most of the free available chlorine used in any pretreatment chlorination. Electro dialysis reversal can lead to a greater concentration of bacteria in the product water than was present in the feed stream due to osmotic loss of water to the waste brine stream. Chlorination of all electro dialysis reversal waters will include a 30-minute chlorine contact time after treatment. Pretreatment chlorination will not be included as part of the 30-minute contact time. The operation and design of electrolytic hypochlorite production equipment, as listed in Chapter 10, is similar to the electro dialysis process. This can make electrolytic production an operational and strategic advantage for electro dialysis-reversal desalination facilities.

CHAPTER 10
WASTE DISPOSAL

10-1. General. Wastes from desalination systems include solids, liquids, and gases. Evaluate each desalination system to determine its particular waste products, then use the appropriate systems to treat or contain these wastes.

A waste disposal overview is shown in figure 10-1. The designer shall also refer to TM's 5-813-3 and 5-813-7 for additional guidance.

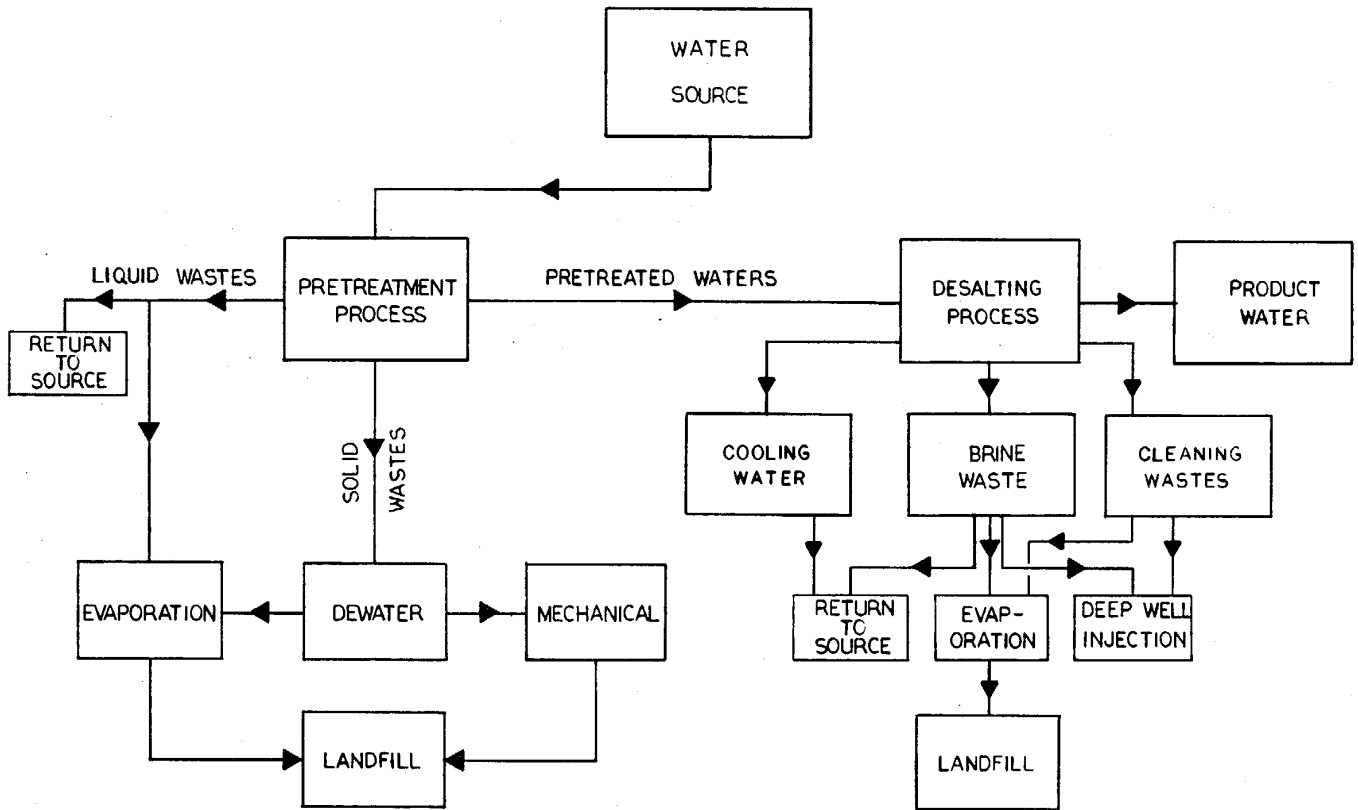

Figure 10-1. Waste disposal overview.

10-2. Pretreatment wastes. Systems that require pretreatment processes produce pretreatment wastes. Solid materials, and the chemicals added to precipitate them, form floc that will be removed from raw water by clarification. The sludges formed must undergo dewatering and are sent to a landfill. Dewatering processes can be mechanical, which are centrifugation

or press operations, or evaporative, which are solar beds or lagoon operations. The alternatives for pretreatment sludge disposal are shown in figure 10-2. In addition to solid wastes, pretreatment processes can produce liquid wastes from filter backwash operations. These liquid wastes often can be reclaimed or treated along with other liquid wastes from desalination process.

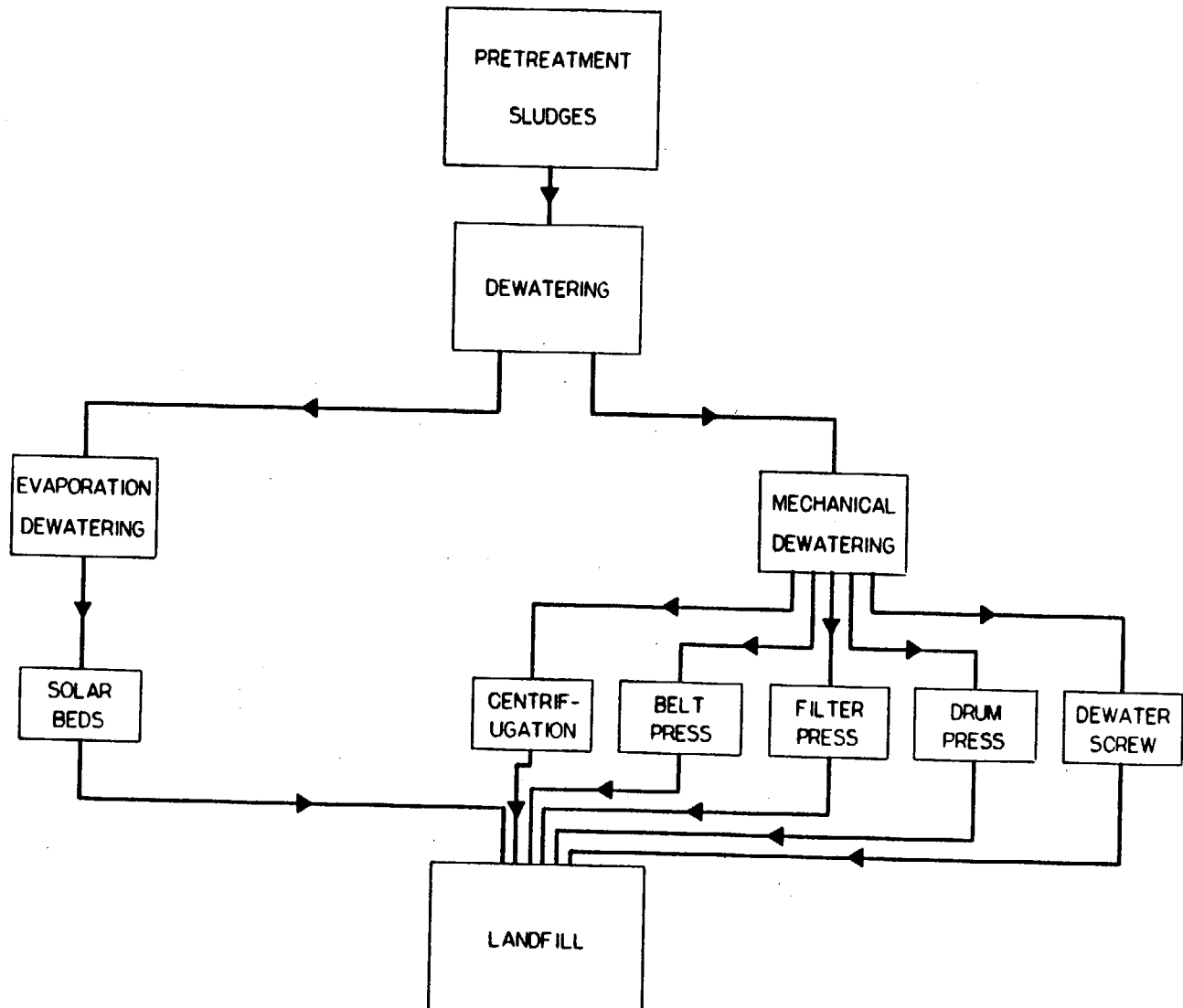

Figure 10-2. Pretreatment sludge disposal.

10-3. Distillation / condensation system wastes .

The waste stream volume produced by distillation/condensation systems is usually less than that produced by other desalination processes. The vaporization process yields concentrated brine with a reduced liquid waste loading. The use of less extensive pretreatment requirements for these systems generally results in a reduction of solid wastes. The cooling water discharge produced by many distillation processes does present a separate thermal discharge problem.

a. Brine return to source. The brines from distillation/condensation processes are highly concentrated. For this reason, brines will be discharged where contamination of the intake water will not occur. The liquid brines will be returned to the raw water source if impact studies show there will be no significant environmental impact. Wetlands and estuarian areas that are often used for discharge are usually productive growth sites for many valuable food species. These areas are easily damaged by thermal discharges and require study to ensure that they are acceptable disposal areas for concentrated desalination waste liquids.

b. Brine evaporation. If it is not feasible to return the brines to the raw water source, then consider the use of evaporation ponds to dry the liquid wastes. The thermal nature of the brine from most distillation/condensation systems can aid evaporation of the wastes to dry salts. In areas where the net evaporation rate is low, but thermal energy sources are available, use thermal evaporation. Thermal evaporation has high energy requirements and usually is not cost-effective.

c. Brine deep-well injection. If discharging the brine to a surface water or evaporation is impractical or uneconomical, deep-well injection of brines is possible. The injection of liquid wastes to deep underground formations can provide a disposal alternative where none was previously available. To properly design and install a deep-well injection facility, a complete geologic and geochemical analysis of the reservoir formation is required. Volumes of less than 53 gallons per minute can be disposed of practically in injection wells, while volumes in excess of 264 gallons per minute will be much more difficult to dispose of by use of this method. Compatibility tests must be run between the proposed waste and a sample of the formation water. This test should ensure that the two waters do not react to form precipitates that may clog the receiving formation. The receiving formation must be separated from any fresh water or the desalination source water by an aquiclude that will ensure that the brine will not contaminate them.

The area must be checked for geologic faults and any manmade penetrations of the aquiclude. The brine must contain less than 15 milligrams per liter of suspended solids, with a maximum size of 20 microns. Figure 10-3 shows a typical injection well. High construction and operating costs and the potential for serious operational problems usually cause deep-well injection to be the last process selected. If deep-well injection, evaporation, or return-to-source liquid-disposal options are not possible, review the entire facility location.

d. Dried salts. When evaporation processes have reduced the brines to dry salts, make evaluations to determine a market value for these salts, as some salts have a value when dried. A landfill operation must be maintained when no market value can be assigned to the dried salts. An overview of brine wastes disposal is shown in figure 10-4.

e. Use of brine. Desalination evaporation ponds make excellent solar stratification ponds. These ponds can be used to produce a stored thermal energy gradient, which can be harvested with a Rankin cycle engine. Electricity from such a system can be used to electrolytically produce chlorine. The total disposal of brine by chlorine production is not expected to ever be economical for the military. The internal production of chlorine for water disinfection is strategic. Presently, the smallest systems available produce over 22 pounds of chlorine per day. The brine concentration must be greater than above 35,000 milligrams of total dissolved solids to be practical. Any hardness in the brine limits efficiency and causes scaling.

f. Cleaning wastes. At regular intervals, distillation systems must be cleaned. This usually involves strong acid cleaning solutions. These solutions must be neutralized and may require lime precipitation of heavy metals before they can be discharged. These wastes can be dried in evaporation ponds or disposed of in injection wells. The volume of cleaning waste is small enough that transportation of the cleaning wastes to commercial hazardous waste disposal facilities is a third alternative. The operation of pretreatment scale control can reduce the frequency of cleaning.

g. Gases. Gas wastes from desalination processes are removed from the system during deaeration or distillation. These gases include

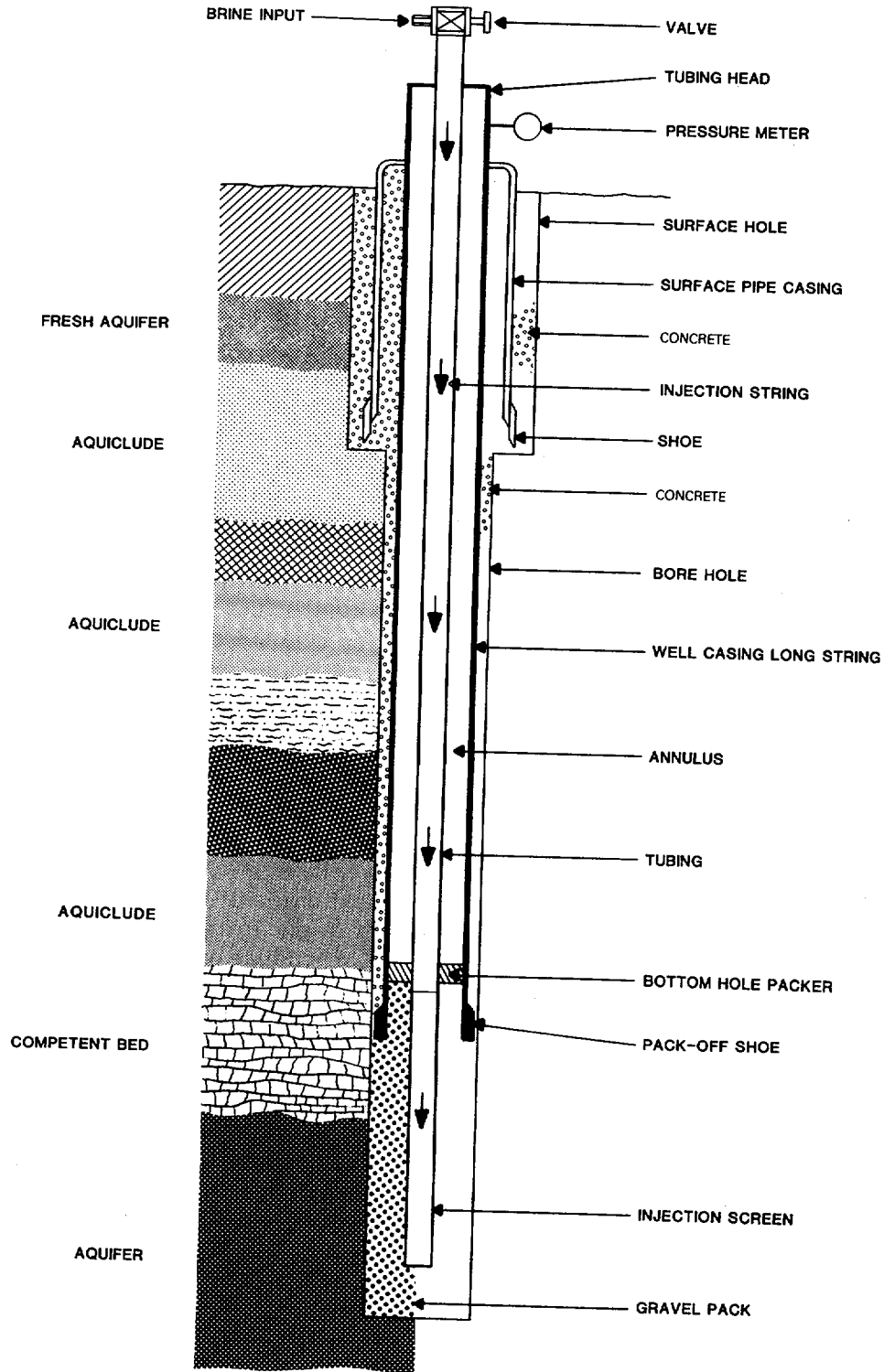

Source: U.S. Army Corps of Engineers

Figure 10-3. Deep-well disposal unit.

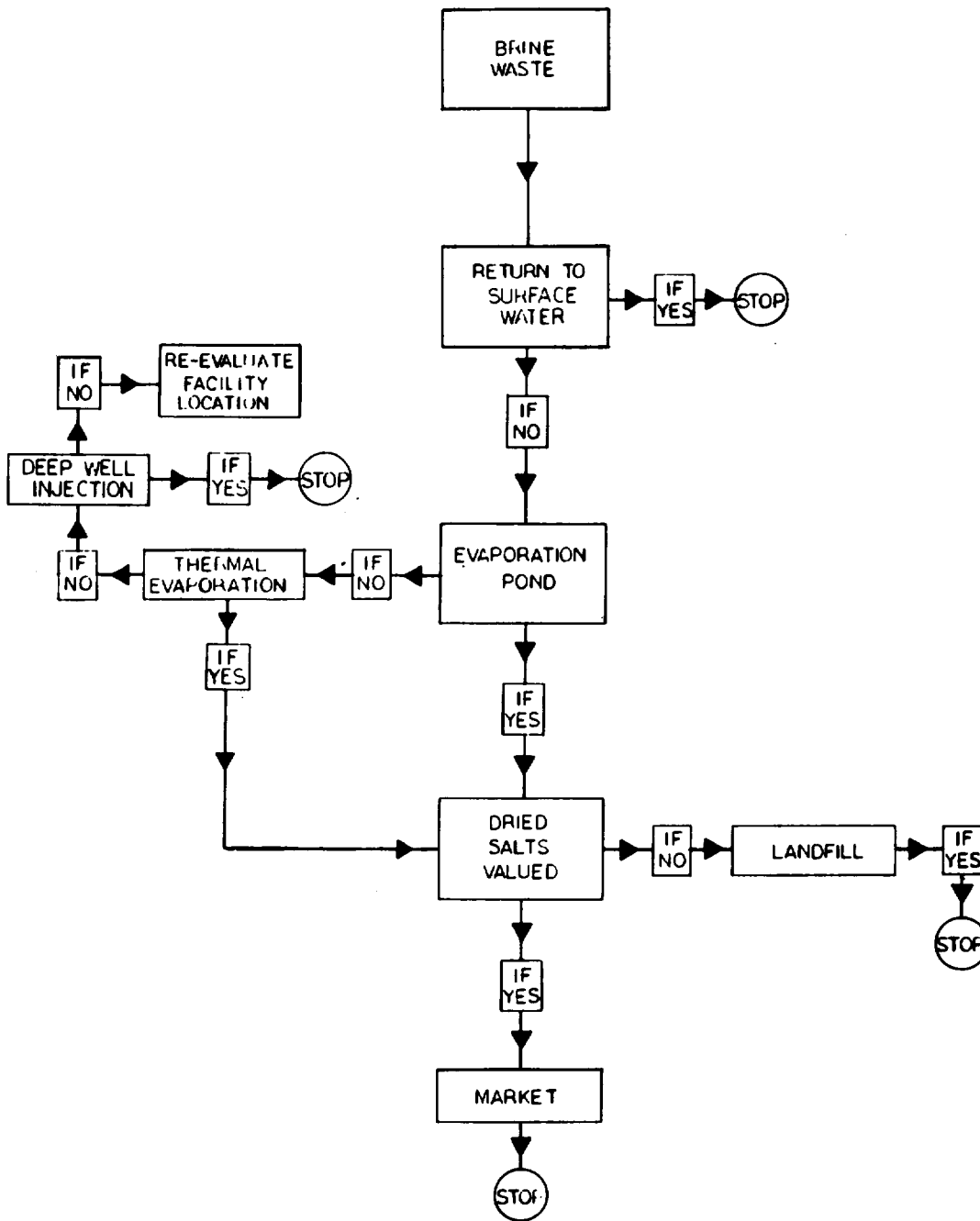

Source U. S. Army Corps of Engineers

Figure 10-4. Brine waste disposal.

carbon dioxide, nitrogen, and oxygen and require no special disposal or monitoring facilities. When hydrogen sulfide gas is removed from raw feed water or toxic and explosive gasses such as methane are generated in waste treatment process, special precautions must be taken for its safe discharge.

10-4. Membrane system wastes.

Membrane desalination systems are the most efficient potable water procedures. However, they produce the most pretreatment wastes, a less concentrated brine waste, and spent membrane modules.

- a. Brines. Brines produced from membrane

desalination are usually less concentrated and are at a lower temperature than distillation/ condensation system brines. The concentration and temperature of these membrane brines make them ideal for disposal by return-to-source technology if it is approved by regulatory authorities. Other methods, such as evaporation or injection, can be used.

b. Membrane modules. Membranes can become fouled, compacted, or destroyed during the normal course of membrane desalination operation. None of the membrane systems in current use present health or environmental hazards when disposed in a landfill. It is customary for the membrane manufacturers to dispose of defective membranes and their modules when replacement is necessary.

10-5. Ion-exchange system wastes.

Neutralize the acid and caustic solutions from ion-exchange regeneration. Then dispose of wastes as concentrated brines. The only other major waste product from ion-exchange systems is the ion-exchange bed itself. Resins that are spent and not to be regenerated can be placed in a landfill.

10-6. Ultimate disposal. All waste streams from desalination processes must reach a point of ultimate or final disposal. Without adequate waste disposal facilities, site development cannot continue.

APPENDIX A
SAMPLE PROBLEMS

APPENDIX A
SAMPLE PROBLEMS

A-1. Sample source and process selection. A facility has been proposed near El Paso, Texas. The final facility population is set at 100 full-time resident personnel. Use TM 5813-1 to obtain water consumption per day. The calculation is as follows:

$$100 \text{ Persons} \times \frac{150 \text{ gallons}}{\text{day Person}} \times \frac{\text{(Capacity)}}{\text{(Factor)}}$$

The nearest flowing river is the Rio Grande, which is 100 miles from the proposed site. Surface water in shallow lakes is also available. Investigations at one location indicate that the lake is much saltier than seawater. A groundwater literature review indicates that several brackish water aquifers exist in the area.

The assumed site data are summarized below:

- 1-Surface lake water is more saline than sea water.
- 2-River water is more than 100 miles away.
- 3-Available brackish water is only slightly saline.
- 4-Solar energy is available.
- 5-Pond evaporation of brine would be about 0.7 multiplied by net pan evaporation (86 inches per year) = 60 inches per year.
- 6-Power lines are remote. A natural gas supply is available at the proposed site. Electricity for the facility could be produced by natural gas engines.

Saline Lake Water

The use of table 4-1 indicates that Rule 1 will apply to this water source (see fig. A-1, Sample use of table 4-1).

Rule 1 states that water saltier than sea water is probably not economical for desalination. A total dissolved solids determination should be run on the lake water to verify excessive salinity.

Assume that the laboratory analyses recommended in table 4-1 were performed and the following was obtained:

Saline lake water
Total dissolved solids 70,000 milligrams per liter

Now use table 4-2 where Rule 1 is applicable. Rule 1 states that if this water must be used, thermal distillation is the only possible process. (See fig. A-2, Sample use of table 4-2). Since alternate brackish water sources are available, this water source is rejected.

Brackish Groundwater

The use of table 4-1 indicates that Rule 6 or Rule 7 will apply to this water source (see fig. A-1).

Rule 6 states that the most economical method to obtain drinking water from brackish water is through reverse osmosis, regardless of how electricity is to be generated. Analyses of total dissolved solids, calcium, sulfate, carbonate, pH, bacterial count, silt density index, turbidity, and low-level oil and grease (less than 1 milligram per liter), as well as the other tests called for in Appendix B, should be performed on test-well water sample.

Rule 7 states that electrodialysis reversal should be investigated for slightly saline water, regardless of electric or steam costs. A total dissolved solids determination, full ionic breakdown, bacterial count, turbidity, and the other tests listed in Appendix B should be done on these test-well samples.

In one area of the site assume that a 230-foot-deep test well is drilled and that the laboratory analyses recommended in table 4-1, Rule 6, were performed and the following data shown in figure A-3 were obtained:

The following data were extracted from the laboratory analysis and bacterial plate count:

230-foot-deep well

total dissolved solids 5,000 milligrams per liter
 Ca^{++} 150 milligrams per liter
 SO_4^- 300 milligrams per liter
 CO_3^- milligrams per liter
 HCO_3^- 172 milligrams per liter

Source: U.S. Army Corps of Engineers

PURPOSE	A	B	C	D	E	F
	If the freshest source of water is:	And if the desired output water will be:	And if electricity is to be generated:	And if the projected cost ratio of <u>264°F Steam:</u> Electricity	Then investigate the cost of:	And have the following tests performed:
1	More salty than sea water <i>(Saline lake water)</i>	Potable water			Transportation of fresher water: distillation can be used but at great expense	TDS
2	Sea water <i>(Brackish well water)</i>	High-pressure boiler feed water	By steam turbine		Distillation followed by ion exchange	TDS, Ca ⁺⁺ , SO ₄ ⁻ , CO ₃ ⁻ , pH refer to water testing requirements in Appendix B
3	Sea water	Potable water	By steam turbine	Greater than $\frac{10 \times 10^6 \text{ BTU}}{1 \text{ kwh}}$	Thermal distillation with or without vapor compression	TDS, Ca ⁺⁺ , SO ₄ ⁻ , CO ₃ ⁻ , pH
4	Sea water	Potable water	By internal combustion engine		Vapor compression distillation and waste heat	TDS, bacterial count, turbidity
5	Sea water	Potable water	No	Less than $\frac{10 \times 10^6 \text{ BTU}}{1 \text{ kwh}}$	Reverse osmosis	TDS, Ca ⁺⁺ , SO ₄ ⁻ , CO ₃ ⁻ , pH, bacterial count, silt density index, turbidity, oil & grease refer to list for reverse osmosis, Appendix B
6	Brackish water	Potable water			Reverse osmosis	TDS, Ca ⁺⁺ , SO ₄ ⁻ , CO ₃ ⁻ , pH, bacterial count, silt density index, turbidity, oil & grease
7	Slightly saline brackish water	Potable water			Electrodialysis reversal	TDS, full ionic breakdown, bacterial count, turbidity refer to list for electrodialysis reversal, Appendix B

Figure A-1. Sample use of table 4-1

Source U.S. Army Corps of Engineers

REJECT	A	B	C	D	E	F
	If the feed water TDS is (mg/liter):	And if the raw feed water suspended solids are:	And if the product of the $[Ca^{++}][SO_4^-]$ moles ² /liter ² is in the reject brine (see sample problem A-3)	And if the oil and grease in the raw feed water is:	Then investigate the cost of:	And have the following pretreatment processes investigated for effectiveness:
1	Greater than 50,000 <i>Saline lake water</i>				Transportation of fresher water; distillation of this water is extremely expensive	Precipitation of less soluble salts
2	Between 20,000 - 50,000 <i>230-foot deep well water</i>	Over 20 NTU	Considerably less than 2×10^{-4}	Greater than 10 mg/liter	Reverse osmosis or distillation and steam and electricity	Alum jar tests, pH adjustment 10-micron or smaller filter plugging
3	Between 20,000 - 50,000 <i>32-foot deep well water</i>	Over 1 NTU	SAMPLE	Less than 10 mg/liter	Reverse osmosis	Alum jar tests 10-micron or smaller filter plugging UV sterilization
4	Between 20,000 - 50,000 <i>32-foot deep well water</i>	Less than 1 NTU SDI greater than 3		Less than 10 mg/liter	Spiral-wound membrane reverse osmosis	pH adjustment, UV sterilization, chlorine disinfection, chlorine residual
5	Between 20,000 - 50,000 <i>500-foot deep well water</i>	SDI under 3		Less than 10 mg/liter	Hollow fine-fiber membrane reverse osmosis	10-micron or smaller filter test, UV sterilization
6	Between 3,000 - 20,000	Over 1,000 mg/liter		Greater than 10 mg/liter	Distillation	pH adjustment, alum jar test
7	Between 3,000 - 20,000			Less than 10 mg/liter	Reverse osmosis	pH adjustment, alum jar test, silt density index, UV sterilization
8	Between 500 - 4,000			Electrodialysis reversal	pH adjustment, alum jar test, 10-micron filter plugging, chlorine disinfection	

*Note: Only 500 mg/liter potable water is considered after table 4-1.

Figure A-2. Sample use of table 4-2.

Source: U.S. Army Corps of Engineers

RULE	A	B	C	D	E	F	G
	If the treated feed water salinity (mg/l) will be (see note):	And the cost ratio of 264°F steam 1 kwh electricity will be:	Alkaline earths on the raw water are such that (see sample problem A-3):	And the treated suspended solids are:	And the designated chlorine residual is:	Then investigate the cost of:	With the following pre- and post-treatment technique costs:
1	Between 20,000 - 50,000		Within 66% of saturation	Less than 1 NTU but SDI greater than 3	0.0 mg/liter	Spiral-wound membrane reverse osmosis	Whatever treatment is necessary to produce D and E
2	Between 20,000 - 50,000		Within 66% of saturation	SDI less than 3	0.0 mg/liter	Hollow fine-fiber membrane reverse osmosis	Whatever treatment is necessary to produce D and E
3	Between 20,000 - 50,000			Less than 1 NTU	Between 1.0 and 0.0 mg/l	Chlorine-resistant membrane reverse osmosis	Whatever treatment is necessary to produce D and E
4	Between 20,000 - 50,000	Greater than 10×10^6 BTU 1 kwh	Within 50% of saturation	Greater than 1 NTU	More than 1 mg/l	Some form of distillation under 185°F	Anti-solent
5	Between 20,000 - 50,000	Greater than 10×10^6 BTU 1 kwh		Greater than 1 NTU	More than 1 mg/l	Some form of distillation	Acid feed (hydrochloric is best)
6	Between 20,000 - 50,000	Greater than 10×10^6 BTU 1 kwh	[Ca ⁺⁺] multiplied by [SO ₄ ⁻] Well Under 2×10^{-6}	Greater than 1 NTU	More than 1 mg/l	Some form of distillation	No pretreatment for calcium sulfate scale control
7	Between 3,000 - 20,000			Less than 1 NTU but SDI greater than 3	Less than 1.0 mg/l**	Brackish water spiral-wound membrane reverse osmosis	Whatever treatment is necessary to produce D and E
8	Between 3,000 - 20,000			SDI less than 3	Less than 1.0 mg/l**	Brackish water hollow fine-fiber membrane reverse osmosis	Whatever treatment is necessary to produce D and E
9	Between 500 - 4,000; and especially when expected to vary by more than 15%			Will not plug 10-micron filter	0.0 mg/l**	Electrodialysis reversal	Turbidity removal To 1 NTU and disinfection to less than 1/100 ml.
10	Is stable at some value between 500 - 1000			SDI less than 3	Less than 1.0 mg/l**	Low pressure/high flux membrane reverse osmosis	Whatever treatment is necessary to produce D and E

230-foot deep well water

32-foot deep well water

500-foot deep well water

SAMPLE

*Note: Only 500 mg/l of potable water is considered after table 4-1. Desalination of water more saline than 50,000 mg/liter is not considered after table 4-2.

**For chlorine-resistant membranes only, and for polyaromatic amide membranes, 0.0 mg/l.

Figure A-4. Sample use of table 4-3.

pH 8.5
 Bacterial count 0/100 milliter (membrane filter technique)
 Silt density index 1
 Turbidity less than 0.01 nephelometric turbidity unit
 Oil and grease less than 1 milligrams per liter

In table 4-2, Rule 7 is applicable (see fig. A-2). Rule 7 states that reverse osmosis processes should be investigated. The low level of silt density index precludes the necessity of an alum jar test.

Use table 4-3 showing that Rule 8 applies (see fig. A-4). Rule 8 states that hollow fine-fiber reverse osmosis specifications should be prepared. No specific pretreatment process is necessary.

In another area of the site a 500-foot test well was drilled. The driller's report indicated that this water had a slight saline taste. Table 4-1, Rule 7 applies (see fig. A-1).

Rule 7 states that electro dialysis reversal should be investigated for slightly saline water, regardless of electric or steam costs. The recommended laboratory analyses are: total dissolved solids, a full ionic breakdown, bacterial count, turbidity, and the other tests for electro dialysis-reversal feed waters listed in Appendix B.

Assume that the laboratory analyses of this water sample give the following data shown in figure A-5.

The following data were extracted from the laboratory analysis and bacterial plate counts:

500-foot-deep well

total dissolved solids 1,000 milligrams per liter

Ca⁺⁺ 100 milligrams per liter as CaCO₃

Mg⁺⁺ 7 milligrams per liter

SO₄⁻ 240 milligrams per liter

CO₃⁻ 0 milligrams per liter

HCO₃⁻ 21 milligrams per liter

Cl⁻ 389 milligrams per liter

Na⁺ 326 milligrams per liter

Bacterial count 0/100 milliliter (membrane filter technique)

Turbidity less than 0.01 nephelometric turbidity unit

Table 4-2, Rule 8 applies (see fig. A-2). Rule 8 states that electro dialysis reversal should be investigated. The low level of turbidity precludes the use of an alum jar test. The low salinity of this sample indicates this to be a superior quality brackish water source.

Application of the preliminary process selection information with table 4-3 results in two possible final process selections. Both Rule 9 and Rule 10 are applicable to this water source. (See fig. A-4)

Rule 9 states that low-pressure high-rate reverse osmosis specifications should be prepared, with antiscalants to be recommended.

Rule 10 states that electro dialysis-reversal specifications should be prepared.

A final decision should be based on the probability of the total dissolved solids fluctuating by more than approximately 15 percent.

Assume a fourth water source was also investigated at this same site. A shallow 32-foot test well was drilled. A preliminary inspection indicated this water was slightly saline and foul tasting with a strong rotten egg smell.

Use of table 4-1 indicates that Rule 6 and Rule 7 may apply (see fig. A-1). Rule 6 states that the most economical method to obtain drinking water from brackish water is through reverse osmosis, regardless of how electricity is to be generated. Analyses of total dissolved solids, calcium, sulfate, carbonate, pH, bacterial count, silt density index, turbidity, low-level oil and grease (below 1 milligram per liter), and any other tests called for in Appendix B should be performed on test-well water samples.

Rule 7 states that for slightly saline water electro dialysis reversal is the most economical method to obtain potable water from brackish water. Analysis of total dissolved solids, a full ionic breakdown, bacterial count, turbidity, and any other tests called for in Appendix B should be performed.

The laboratory analyses of this water sample give the following data shown in figure A-6:

PHYSICAL AND CHEMICAL ANALYSIS OF WATER

1. Sample Number: Sample Problem A-1b 2. Date and Hour Collected: 7-13-82
 3. From: El Paso, Tx 10:00 AM
 4. To:
 5. Sample Location and Description Well 2 (500-foot deep well) (Ground water)
 6. Requested By:
 7. Collected By: Mr. William Diggem
 8. Preservation: Reason for Request: Water Source Evaluation

LABORATORY REPORT						
X	ITEM	UNITS	RESULTS	X	ITEM	RESULTS, mg/l
X	CO ₂ (1) when fresh from well	mg/l	0	X	Ca	40
X	O ₂ (dissolved)	"	0.0	X	Mg	7
X	H ₂ S	"	<0.1	X	Na and K	326
X	PH	units	<0.1	X	OH	0.0
X	Temp.	°F/°C	55/13	X	HCO ₃	21
X	Color	units	None	X	CO ₃	0.0
X	Turbidity (3)	NTU	<0.01 SDI=1	X	SO ₄	240
X	*P Alkalinity	mg/l	0.0	X	Cl	384
X	*MO Alkalinity	"	17	X	NO ₃	1.0
X	*Total Hardness	"	129	X	Fe (total)	<0.01
X	*Non-Carbonate Hardness	"	112	X	Mn	0.1
X	*Carbonate Hardness	"	17	X	SiO ₂	30
X	Total Dissolved Solids	"	1,000	X	F	0.5
X	Specific Conductance	µmhos	1,800	X	As	<0.001
	Others (specify as req'd)			X	Se	<0.5
X	PO	PPM	<0.1	X	Pb	<0.001
X	10 mg Oil/Grease (2)	PPM	<1.0	X	B	<0.2
X	Molybdenate Reactive Silica	PPM	29	X	Cu	<0.01
X	Molybdenate Non-Reactive Silica	PPM	1	X	Zn	<0.1
X	Bacterial Count TPC		<0.01/100ml	X	Cr (+6)	<0.0001
X	Phenolic Compounds (PPB)		<0.0001	X	Cd	<0.0001
	*As CaCO ₃ Cl ₂ (2)	PPM	<0.1	X	CN	<0.0001

X Indicate if required

- (1) 10 Minute Demand.
- (2) Utilize a 50 fold, low temperature, low pressure concentrating technique to verify <10 mg/l Oil & Grease.
- (3) A Silt Density Index determination must be made on all waters with a turbidity of less than 2 NTU.

Figure A-5. Water analysis (sample problem A-1b).

PHYSICAL AND CHEMICAL ANALYSIS OF WATER

1. Sample Number: *Sample Problem A1c* 2. Date and Hour Collected: *7-13-82*
 3. From: *El Paso, Texas* 9:00 AM
 4. To:
 5. Sample Location and Description *Well 3 (32-foot deep well)*
 6. Requested By:
 7. Collected By: *Mv. William Digger*
 8. Preservation: Reason for Request: *Water Source Evaluation*

LABORATORY REPORT						
X	ITEM	UNITS	RESULTS	X	ITEM	RESULTS, mg/l
X	CO ₂	mg/l	2	X	Ca	20
X	O ₂ (dissolved)	"	0	X	Mg	64
X	H ₂ S	"	> 300	X	Na and K	1368
X	PH	units	5.0	X	OH	0
X	Temp.	°F/°C	60/15.6	X	HCO ₃	0
X	Color	units	Brown to Red Absorbance=5 at 400 nm	X	CO ₃	0
X	Turbidity	NTU	1151	X	SO ₄	> 1000
X	*P Alkalinity	mg/l	0.0	X	Cl	1500
X	*MD Alkalinity	"	0.0	X	NO ₃	< 0.01
X	*Total Hardness	"	313	X	Fe (total)	< 0.0001
X	*Non-Carbonate Hardness	"	313	X	Mn	< 0.0001
X	*Carbonate Hardness	"	None CPH had dropped below 4.3 during handling	X	SiO ₂	< 0.1
X	Total Dissolved Solids	"	4,000	X	F	< 0.001
X	Specific Conductance	µmhos	6,000	X	As	< 0.001
	Others (specify as req'd)			X	Se	1.0
X	PO	PPM	< 1	X	Pb	< 0.0001
X	10mg/L Oil/Grease	PPM	100	X	B	< 0.2
X	Molybdenate Reactive Silica	PPM	< 0.1	X	Cu	< 0.01
X	Molybdenate Non-Reactive Silica	PPM	< 0.1	X	Zn	< 0.1
X	Phenolic Compounds (PPB)	PPM	< 0.0001	X	Cr (+6)	< 0.0001
X	Cl ₂ demand calculated from H ₂ S	PPM	> 2800	X	Cd	< 0.0001
	*As CaCO ₃			X	CN	< 0.0001

X Indicate if required

- (1) 10 Minute Demand.
- (2) Utilize a 50 fold, low temperature, low pressure concentrating technique to verify < 10 mg/l Oil & Grease.
- (3) A Silt Density Index determination must be made on all waters with a turbidity of less than 2 NTU.

Figure A-6. Water analysis (sample problem A-1c).

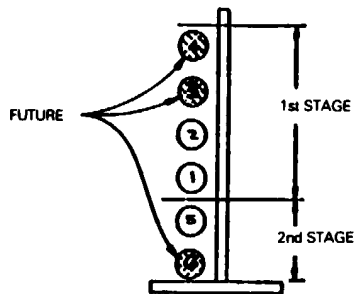

VESSEL PLACEMENT FOR STAGING ARRANGEMENT

NOTE. WHEN POSITIONING THE PERMEATORS FOLLOW NUMERICAL ORDER AS INDICATED ABOVE

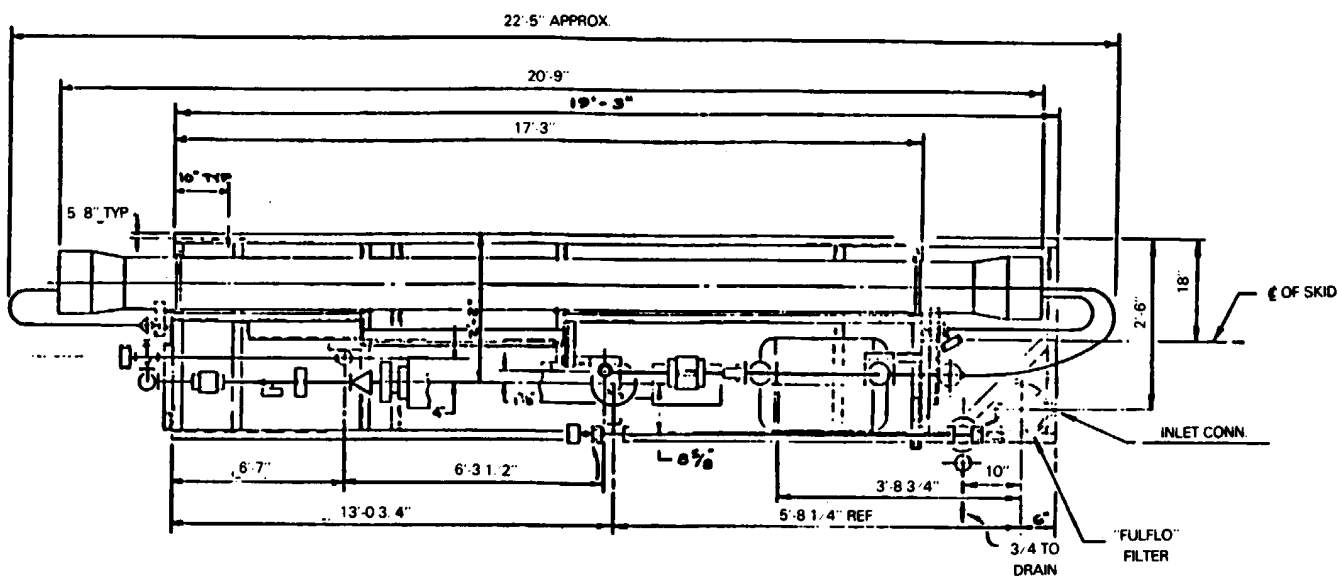

Figure A-7. Low Pressure Reverse Osmosis System.

Source: The Permutit Co., Inc.

The following data were extracted from laboratory analysis and bacterial plate counts:

- 32-foot-deep well
- total dissolved solids 4,000 milligrams per liter
- Ca⁺⁺ 50 milligrams per liter as CaCO₃
- Mg⁺⁺ 64 milligrams per liter
- SO₄⁼ 1,000 milligrams per liter

CO₃⁻ absent due to pH

pH 3.5

Bacterial count 50,000/100 milliliters (sulfide media, not a coliform test)

Silt density index 6.67 (Complete plugging in 2 minutes)

Turbidity 115 nephelometric turbidity unit (Total Suspended Solids 250 milligrams per liter)

Oil and grease 100 milligrams per liter

Use of these laboratory analyses with table 4-2 indicates that Rule 8 applies (see table A-2). Rule 8 states that electro dialysis reversal should be investigated. The elevated bacterial count indicates the possible contamination of the source with sewage effluent. This possible contamination should be investigated.

Assume that a bacteriological examination of a water sample indicated that the bacteria present are sulfur oxidizing bacteria, responsible for the low pH of the sample. The bacterial count may not reflect the true level of bacteria in the source, since aeration of the sample stimulates bacterial growth in the presence of the sulfide. Although no sewage effluent contamination is detected, potential taste and odor problems with this water source are severe.

Use of table 4-3 results in three possible final process selections. Rule 7, Rule 8, and Rule 9 are all applicable for this water source (see fig. A-4).

Rule 7 states that if water is below 1 nephelometric turbidity unit and has a silt density index above 4, specifications for spiral-wound reverse osmosis processes should be prepared.

Rule 8 states that if water is clear and has a silt density index of less than 4, specifications for hollow fine-fiber reverse osmosis processes should be prepared.

Rule 9 states that electro dialysis reversal specifications should be prepared. While no individual rule fits completely, Rule 9 appears to be the most applicable. As this last example demonstrates, these tables are not intended to supplant sound engineering judgment. They do not include all possible waters or conditions found in the continental United States.

Of the four water sources considered in this sample problem, the low salinity and turbidity of the 500-foot-deep well would indicate that it would be the most economical water source for development. The other three sources should be rejected. A drawing of a reverse osmosis system similar to that which would be used in treating such a well water is shown in Figure A-7.

A-2. Sample source and process selection. A facility is planned for the California coast in an area not currently served by an electric utility. Fresh surface water and groundwater do not exist or are unavailable in the area. The only water source is sea water. The facility will have 3,000 permanent personnel. Natural gas is available. Use TM 5-813-1 to determine daily water consumption. The calculation follows:

$$3,000 \text{ Persons} \times \frac{150 \text{ gallons}}{\text{day person}} \times 1.5 \text{ (Capacity)} \text{ (Factor)}$$

Daily water consumption = 675,000 gallons per day

The area is reasonably arid with a mean summer temperature greater than 59 degrees Fahrenheit and a mean winter temperature greater than about 48 degrees Fahrenheit (see TM 5-813-1, figs. 2-5 and 2-7). Brine disposal at sea is feasible. It is estimated that electricity would cost more than \$.50/kilowatt hour if the facility could install a power transmission line. A natural gas-powered internal combustion engine could produce power for approximately \$.60/kilowatt hour.

Summarize this data as shown below:

- 1-No fresh surface water or fresh ground water are available in the area.
- 2-The site is on the Pacific Ocean and sea water is available.
- 3-Solar energy is available.
- 4-Brine disposal at sea is feasible.
- 5-Power lines are remote. A natural gas supply is available for electricity generation by internal combustion engine.

Use of table 4-1 with the above data indicates that Rule 4 will apply to a sea water source (see fig. A-8).

Source: U.S. Army Corps of Engineers

RCM	A	B	C	D	E	F
	If the freshest source of water is:	And if the desired output water will be:	And if electricity is to be generated:	And if the projected cost ratio of $\frac{264^{\circ}\text{F Steam}}{\text{Electricity}}$	Then investigate the cost of:	And have the following tests performed:
1	More salty than sea water	Potable water			Transportation of fresher water: distillation can be used but at great expense	TDS
2	Sea water See Water	High-pressure boiler feed water	By steam turbine		Distillation followed by ion exchange	TDS, Ca^{++} , SO_4^{-} , CO_3^{-} , pH refer to water testing requirements in Appendix B
3	Sea water	Potable water	By steam turbine	$\frac{\text{Greater than } 10 \times 10^6 \text{ BTU}}{1 \text{ kwh}}$	Thermal distillation with or without vapor compression	TDS, Ca^{++} , SO_4^{-} , CO_3^{-} , pH
4	Sea water	Potable water	By internal combustion engine		Vapor compression distillation and waste heat	TDS, bacterial count, turbidity
5	Sea water	Potable water	No	$\frac{\text{Less than } 10 \times 10^6 \text{ BTU}}{1 \text{ kwh}}$	Reverse osmosis	TDS, Ca^{++} , SO_4^{-} , CO_3^{-} , pH, bacterial count, silt density index, turbidity, oil & grease refer to list for reverse osmosis, Appendix B
6	Brackish water	Potable water			Reverse osmosis	TDS, Ca^{++} , SO_4^{-} , CO_3^{-} , pH, bacterial count, silt density index, turbidity, oil & grease
7	Slightly saline brackish water	Potable water			Electrodialysis reversal	TDS, full ionic breakdown, bacterial count, turbidity refer to list for electrodialysis reversal, Appendix B

SAMPLE

Figure A-8. Sample use of table 4-1.

Rule 4 states that when sea water is used and internal combustion engines are being considered for power production, vapor-compression distillation should be considered. Laboratory analyses of the sea water should include total dissolved solids, bacterial count, and turbidity. An evaluation of possible waste heat recovery from the power generation system should also be undertaken.

Assume the results from the laboratory analyses recommended in table 4-1, shown in figure A-9, are as follows (the format for the Physical and Chemical Analysis of Water used in this manual is for illustration purposes only and users are advised to develop their own format): The following data were extracted from the laboratory analysis and bacterial plate counts:

Seawater

TDS 35,000 milligrams per liter

Ca⁺⁺ 350 milligrams per liter as Ca⁺⁺

SO₄⁻ 2,650 milligrams per liter

pH 7.2

Bacterial count 10/100 milliliters (membrane filter technique)

Turbidity 15 nephelometric turbidity units

Assume that the following was obtained from analysis of the design of the internal combustion engine to be used for power production.

Waste heat: Approximately 1.0×10^9 British thermal units per day between 264 degrees Fahrenheit and 68 degrees Fahrenheit.

Calculating the cost of electricity from the power utility \$.50/kilowatt hour versus the cost of waste heat steam which can be produced at less than $\$0.03/1.0 \times 10^6$ British thermal units gives the following:

$$\$0.50/\text{kilowatt hour}/\$0.03/1.0 \times 10^6 \text{ British thermal unit} = 16.67 \times 10^6 \text{ British thermal unit per kilowatt hour}$$

Use of this information and table 4-2 indicates that Rule 3 is applicable for this facility (see fig. A-10). Steam and electricity costs are compared as a ratio to eliminate dollar value changes, but technology could easily change the 10.0×10^6 British thermal unit per kilowatt hour guideline. Rule 3 states that a comparison between reverse osmosis and distillation/condensation systems should be made. Additional testing should include an alum jar test and 10-micron filter plugging, as well as evaluation of the effects of ultraviolet (UV) sterilizations.

Assume that the results from the recommended testing indicate that the turbidity can be reduced by alum addition to below 1 nephelometric turbidity unit, and a 10-micron filter will not plug rapidly on this treated water. Assume that a computer analysis in addition to figure 3-2, TM 5-813-1, shows scaling is not a problem until the total dissolved solids is concentrated about 1.5 times at temperatures below 212 degrees Fahrenheit.

Use of table 4-3 indicates that Rule 3 applies for this facility (see fig. A-11).

Rule 5 states that if temperature over 212 degrees Fahrenheit are economical for distillation at this site, acid feed may be necessary to prevent scaling.

A distillation/condensation system with an associated vapor-compression system should be evaluated. Specifications should be prepared. A drawing of a sea water distillation system capable of recompressing low-grade steam is shown in figure A-12.

A-3. Calcium sulfate solubility product (Ca SO₄ · XH₂O) scale. As can be seen below, the calculation of a solubility limit is moderately complex for a simple, pure solute at low concentration. Hand calculation is not practical in solutions containing a few percent of several cationic and/or several anionic species. Most manufacturers have computer programs that include the concentration polarization factors and any other surface-related factors that set the scaling limits for their products. The following is a sample calculation of calcium ion sulfate ion, acid-base solubility for 64 degrees Fahrenheit. To estimate solubilities for distillation condensation or other temperatures different from 64 degrees Fahrenheit, the solubility product for calcium sulfate at temperatures up to 392 degrees Fahrenheit can be found in reference (4).

These calculations are suitable for initial design and process selection (see tables 4-2 and 4-3). The principle purpose of these calculations is to indicate waters that are well below saturation and therefore do not present scaling problems. A full computer evaluation of scaling potential should be performed by the manufacturer as part of the final bid.

PHYSICAL AND CHEMICAL ANALYSIS OF WATER

1. Sample Number: *Sample Problem A-2* 2. Date and Hour Collected: *7-6-82*
 3. From: *Sea Coast, California* 4:00 PM
 4. To:
 5. Sample Location and Description *Sea Coast Point, Calif (Surface Sea Water)*
 6. Requested By:
 7. Collected By: *Joseph Blow*
 8. Preservation: Reason for Request: *Proposed Site for Base & Deval. Facility*

LABORATORY REPORT						
X	ITEM	UNITS	RESULTS	X	ITEM	RESULTS, mg/l
X	CO ₂ Free	mg/l	18	X	Ca	350
X	O ₂ (dissolved)	"	8	X	Mg	1300
X	H ₂ S	"	0.01	X	Na and K	11,000
X	PH	units	7.2	X	OH ^{Computed} P/mo	0
X	Temp.	*F/*C	50/10	X	HCO ₃ "	142
X	Color	units	none	X	CO ₃ "	0
X	Turbidity	NTU	15 SDI=6.66	X	SO ₄	2650
X	*P Alkalinity	mg/l	0	X	Cl	19,000
X	*MO Alkalinity	"	166	X	NO ₃	<0.1
X	*Total Hardness	"	6227	X	Fe (total)	<0.05
X	*Non-Carbonate Hardness	"	5994	X	Mn	<0.05
X	*Carbonate Hardness	"	116	X	SiO ₂	3.5
X	Total Dissolved Solids	"	34.550	X	F	1.3
X	Specific Conductance	µmhos	51,000		As	
	Others (specify as req'd)				Se	
X	Molybdenate Reactive Silicate	PPM	2.0		Pb	
X	Molybdenate non-Reactive Silicate	PPM	0.5		B	
X	Bromide (Br)	PPM	65		Cu	
X	10 mg/L Oil	PPM	<1.0		Zn	
					Cr (+6)	
					Cd	
	*As CaCO ₃				CN	

- X Indicate if required
- (1) 10 Minute Demand.
 - (2) Utilize a 50 fold, low temperature, low pressure concentrating technique to verify <10 mg/l Oil & Grease.
 - (3) A Silt Density Index determination must be made on all waters with a turbidity of less than 2 NTU.

Figure A-9. Water analysis (sample problem A-2).

CUR	A	B	C	D	E	F
	If the feed water TDS is (mg/liter):	And if the raw feed water suspended solids are:	And if the product of the $[Ca^{++}] [SO_4^-]$ moles ² /liter ² is in the reject brine (see sample problem A-3)	And if the oil and grease in the raw feed water is:	Then investigate the cost of:	And have the following pretreatment processes investigated for effectiveness:-
1	Greater than 50,000				Transportation of fresher water; distillation of this water is extremely expensive	Precipitation of less soluble salts
2	Between 20,000 - 50,000	Over 20 NTU	Considerably less than 2×10^{-4}	Greater than 10 mg/liter	Reverse osmosis or distillation and steam and electricity	Alum jar tests, pH adjustment 10-micron or smaller filter plugging
3	Between 20,000 - 50,000	Over 1 NTU		Less than 10 mg/liter	Reverse osmosis	Alum jar tests 10-micron or smaller filter plugging UV sterilization
4	Between 20,000 - 50,000	Less than 1 NTU SDI greater than 3		Less than 10 mg/liter	Spiral-wound membrane reverse osmosis	pH adjustment, UV sterilization, chlorine disinfection, chlorine residual
5	Between 20,000 - 50,000	SDI under 3		Less than 10 mg/liter	Hollow fine-fiber membrane reverse osmosis	10-micron or smaller filter test, UV sterilization
6	Between 3,000 - 20,000	Over 1,000 mg/liter	Considerably less than 2×10^{-4}	Greater than 10 mg/liter	Distillation	pH adjustment, alum jar test
7	Between 3,000 - 20,000			Less than 10 mg/liter	Reverse osmosis	pH adjustment, alum jar test, silt density index, UV sterilization
8	Between 500 - 4,000				Electrodialysis reversal	pH adjustment, alum jar test, 10-micron filter plugging, chlorine disinfection

See Water

SAMPLE

†Note: Only 500 mg/liter potable water is considered after table 4-1.

Figure A-10. Sample use of table 4-2.

Source: US Army Corps of Engineers

RCR	A	B	C	D	E	F	G
	If the treated feed water salinity (mg/l) will be (see note):	And the cost ratio of 264°F steam 1 kwh electricity will be:	Alkaline earths on the raw water are such that (see sample problem A-3):	And the treated suspended solids are:	And the designated chlorine residual is:	Then investigate the cost of:	With the following pre- and post-treatment technique costs:
1	Between 20,000 - 50,000		Within 66% of saturation	Less than 1 NTU but SDI greater than 3	0.0 mg/liter	Spiral-wound membrane reverse osmosis	Whatever treatment is necessary to produce D and E
2	Between 20,000 - 50,000		Within 66% of saturation	SDI less than 3	0.0 mg/liter	Hollow fine-fiber membrane reverse osmosis	Whatever treatment is necessary to produce D and E
3	Between 20,000 - 50,000			Less than 1 NTU	Between 1.0 and 0.0 mg/l	Chlorine-resistant membrane reverse osmosis	Whatever treatment is necessary to produce D and E
4	Between 20,000 - 50,000	Greater than 10×10^6 BTU 1 kwh	Within 50% of saturation	Greater than 1 NTU	More than 1 mg/l	Some form of distillation under 185° F	Anti-scalent
5	Between 20,000 - 50,000	Greater than 10×10^6 BTU 1 kwh		Greater than 1 NTU	More than 1 mg/l	Some form of distillation	Acid feed (hydrochloric is best)
6	Between 20,000 - 50,000	Greater than 10×10^6 BTU 1 kwh	[Ca ⁺⁺] multiplied by [SO ₄ ⁻] Well Under 2×10^{-6}	Greater than 1 NTU	More than 1 mg/l	Some form of distillation	No pretreatment for calcium sulfate scale control
7	Between 3,000 - 20,000			Less than 1 NTU but SDI greater than 3	Less than 1.0 mg/l**	Brackish water spiral-wound membrane reverse osmosis	Whatever treatment is necessary to produce D and E
8	Between 3,000 - 20,000			SDI less than 3	Less than 1.0 mg/l**	Brackish water hollow fine-fiber membrane reverse osmosis	Whatever treatment is necessary to produce D and E
9	Between 500 - 4,000 and especially when expected to vary by more than 15%			Will not plug 10-micron filter	0.0 mg/l**	Electrodialysis reversal	Turbidity removal To 1 NTU and disinfection to less than 1/100 ml.
10	Is stable at some value between 500 - 1000			SDI less than 3	Less than 1.0 mg/l**	Low pressure/high flux membrane reverse osmosis	Whatever treatment is necessary to produce D and E

*Note: Only 500 mg/l of potable water is considered after table 4-1

Desalination of water more saline than 50,000 mg/liter is not considered after table 4-2.

**For chlorine-resistant membranes only, and for polyaromatic amide membranes, 0.0 mg/l.

Figure A-11. Sample use of table 4-3.

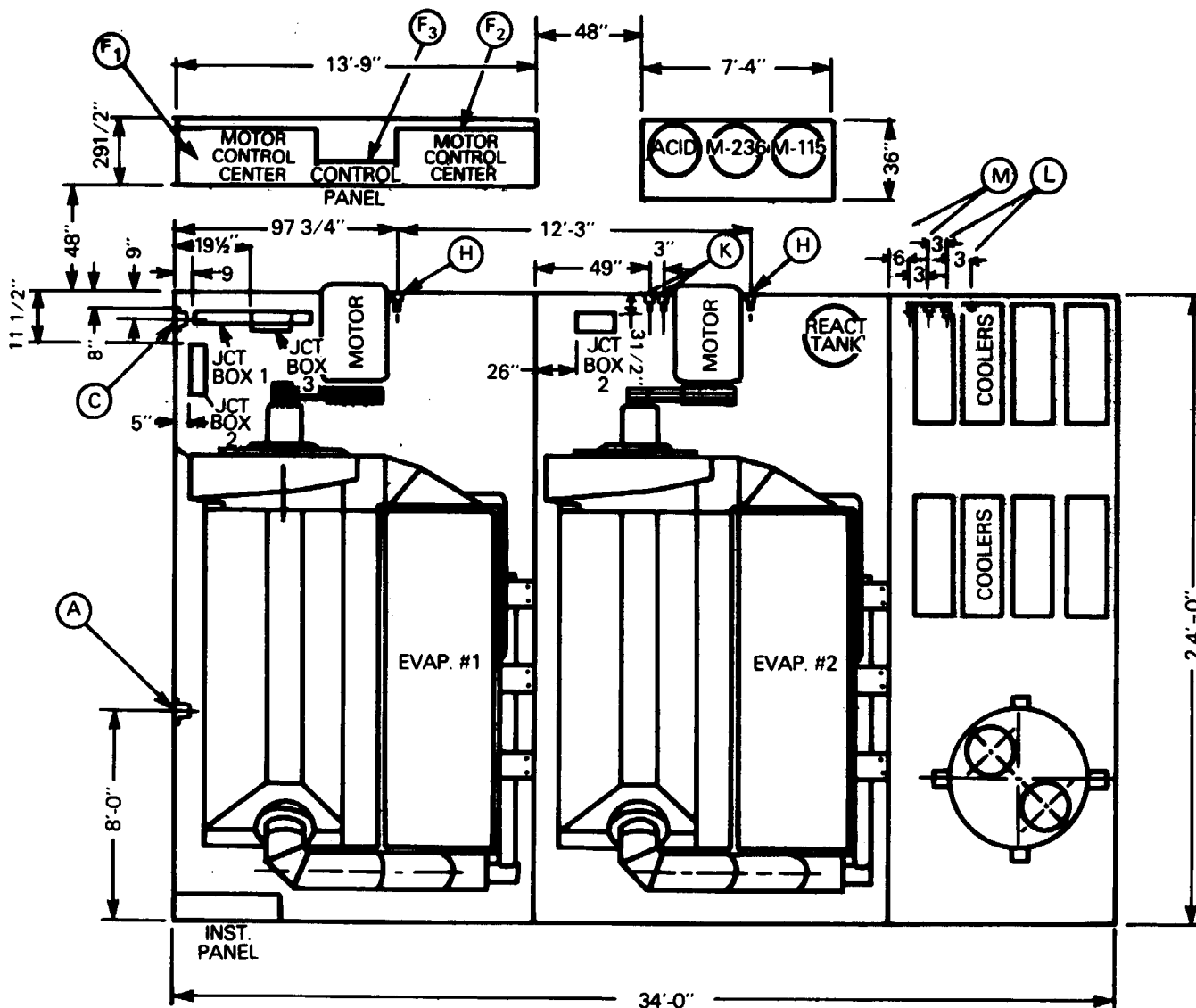

Figure A-12. Plan view of a vapor compression system.

Symbols:

- [Ca⁺⁺] = Double-ionized calcium concentration in moles/liter (molar)
- [SO₄⁼] = Double-ionized sulfate concentration in moles/liter (molar)
- [HSO₄⁻] = Undissociated bisulfate ion concentration in moles/liter (molar)
- [H⁺] = The dissociated hydrogen ion concentration in moles/liter (molar)
- pK_{sp} = The negative base 10 logarithm of the solubility product
- K_{sp} = The product of the concentration of the ions in a saturated solution that is beginning to form crystals
- pH = The negative base 10 logarithm of the hydrogen ion concentration
- pOH = The negative base 10 logarithm of the hydroxyl ion concentration
- pK_a = The negative base 10 logarithm of the acid dissociation constant
- K_a = The ratio of the concentration of dissociated acid and hydrogen ion concentration to the undissociated acid concentration at equilibrium

Assume that:

The water contains 1,000 parts per million as CaCO₃, 2,650 parts per million SO₄ as total sulfate and is at pOH = 11. Assume that the temperature is close to 64 degrees Fahrenheit and that there is no ion pairing of SO₄ other than hydrogen ion as HSO₄.

The pK_{sp} of calcium sulfate is given as 3.6.

The pK_a of sulfuric acid second dissociation is given as 1.92.

The density of the saline water sample is 1,025 grams/liter at 64 degrees Fahrenheit.

To convert calcium and sulfate concentrations in the expected brine (density = 1025 grams/liter) to molarity use the following calculations:

$$\begin{aligned} \text{Molar Concentration} &= \frac{1 \text{ gram Ca}^{++} \text{ as CaCO}_3}{1000 \text{ grams H}_2\text{O}} \times \frac{1025 \text{ grams}}{1 \text{ liter}} \times \frac{1 \text{ mole Ca}^{++}}{100 \text{ grams CaCO}_3^{**}} \\ &= 0.01025 \text{ molar} \end{aligned}$$

$$\begin{aligned} \text{Molar Concentration of SO}_4 &= \frac{2650 \text{ milligrams SO}_4^- \text{ as total SO}_4^-}{1000 \text{ grams H}_2\text{O}} = \frac{1025 \text{ grams}}{\text{liter}} \times \frac{1 \text{ mole SO}_4^-}{96,063 \text{ milligrams SO}_4^-} \\ &= 0.0283 \text{ molar [SO}_4^-] \end{aligned}$$

$$\text{Molar concentration of sulfate} = 0.0283 \text{ molar [SO}_4^-]$$

*molecular weight SO₄⁻ in milligram/mole

**molecular weight CaCO₃

$$-\log_{10} ([\text{Ca}^{++}][\text{SO}_4^-]) = \text{pK}_{\text{sp}} = 3.6$$

$$\therefore K_{\text{sp}} = ([\text{Ca}^{++}][\text{SO}_4^-]) = 2.51 \times 10^{-4}$$

$$\text{pH} + \text{pOH} = 14$$

$$\text{pOH} = 11 \quad \therefore \text{pH} = 3$$

$$\text{pH} = -\log [\text{H}^+] \quad \therefore [\text{H}^+] = 10^{-3} \text{ moles/liter}$$

$$-\log_{10} ([\text{H}^+][\text{SO}_4^-]/[\text{HSO}_4^-]) = \text{pK}_a = 1.92$$

$$\therefore K_a = 1.20 \times 10^{-2} = [\text{H}^+][\text{SO}_4^-]/[\text{HSO}_4^-]$$

∴ for this water, which is at pOH = 11

$$[\text{SO}_4^-]/[\text{HSO}_4^-] = 1.2 \times 10^{-2}/10^{-3} = 12 \quad \therefore \text{of the total sulfate}$$

$$\frac{12}{[12 + 1]} = \frac{12}{13} \text{ is } [\text{SO}_4^-] \quad \therefore [\text{SO}_4^-] = .92 [\text{Total SO}_4^-]$$

$$\text{(for pH 1 } [\text{SO}_4^-] = 0.107 [\text{Total SO}_4^-])$$

Since only 92 percent of this total SO₄⁻ is in solution as SO₄⁻ and 8 percent is as HSO₄⁻ at pH 3, the following equation is applicable:

$$\begin{aligned} [\text{Ca}^{++}] \times \frac{\text{percent as SO}_4^-}{100} \times [\text{SO}_4^-] &= (.01025)(.0283) \frac{92}{100} \\ &= 2.67 \times 10^{-4} \end{aligned}$$

$$2.67 \times 10^{-4} \text{ is greater than } K_{\text{sp}} = 2.51 \times 10^{-4}$$

∴ Unless other ions complex Ca⁺⁺ or SO₄⁻, scaling will be a problem at 64 degrees Fahrenheit. (See figure 5-2.)

A-4. Ion- exchange desalination. A permanent installation is proposed near Haftrak, Arizona. The potable water treatment system will serve a resident population of 2,000. Use TM 5-813-1 to obtain water consumption per day. The calculation is as follows:

$$\begin{aligned} &\frac{150 \text{ gallons}}{2,000 \text{ persons} \times \text{day Person} \times 1.5 \text{ capacity factor}} = 450,000 \text{ gallons per day} \end{aligned}$$

The area is hot and dry, with annual average maximum daily air temperature of 55 degrees Fahrenheit and a net pan evaporation of approximately 87 inches. Ground water is available, as well as an average chemical analysis.

PHYSICAL AND CHEMICAL ANALYSIS OF WATER

- 1. Sample Number: Sample Problem A-4
 - 2. Date and Hour Collected: 07-13-82
 - 3. From: HAFTRAK, A2
 - 4. To:
 - 5. Sample Location and Description Well A-2-4 Groundwater
 - 6. Requested By:
 - 7. Collected By: MISS BUZLEY
 - 8. Preservation:
- Reason for Request: Water Quality Survey

LABORATORY REPORT						
X	ITEM	UNITS	RESULTS	X	ITEM	RESULTS, mg/l
	CO ₂	mg/l	0		Ca	20
	O ₂ (dissolved)	"			Mg	3
	H ₂ S	"			Na and K	225
	PH	units	8.5		OH	0
	Temp.	*F/°C	58/14.4		HCO ₃	324
	Color	units			CO ₃	25
	Turbidity	NTU			SO ₄	77
	*P Alkalinity	mg/l	21		Cl	107
	*MO Alkalinity	"	300		NO ₃	9
	*Total Hardness	"	62		Fe (total)	<0.01
	*Non-Carbonate Hardness	"	0		Mn	<0.01
	*Carbonate Hardness	"	62		SiO ₂	5
	Total Dissolved Solids	"	800		F	2.0
	Specific Conductance	µmhos			As	
	Others (specify as req'd)				Se	
					Pb	
					B	
					Cu	
					Zn	
					Cr (+6)	
					Cd	
	*As CaCO ₃				CN	

X Indicate if required

Figure A-13. Water analysis (sample problem A-4).

The assumed site data are summarized below:

- 1-Available ground water is a consideration.
- 2-Ion exchange will be considered for the potable water treatment.
- 3-Pond evaporation of regenerate wastes would be approximately 0.7, multiplied by net pan evaporation (87 inches per year), which equals 508 inches per year.

Ground Water

Laboratory analyses are available, and the following water quality data are shown in figure A-13.

Ion-Exchange Resin Selection

On the physical and chemical analysis of water report (fig. A-13), the following data were extracted:

Total dissolved solids	800 milligrams per liter
Sulfate	77 milligrams per liter
Chloride	107 milligrams per liter
Nitrate	9 milligrams per liter
Iron	0.01 milligrams per liter
Manganese	0.01 milligrams per liter
Fluoride	2.0 milligrams per liter

In comparing the extracted data with the potable water maximum contaminant levels found in Army Medical Corps documents, total dissolved solids is the only limit exceeded.

The choice of the proper ion-exchange method depends on the composition of the raw water and its intended use. A strongly acidic cation exchange resin replaces the cations in the raw water with hydrogen, and the effluent from the exchanger unit is both softened and acidic. Since sodium is the most predominant cationic ion in the well water, a reduction of sodium and associated alkalinity will reduce the total dissolved solids to within the potable water limits. Therefore, a strongly acidic cation exchange resin system is indicated. No specific pretreatment process is necessary.

Neutralization

A strongly acidic cation exchange system converts carbonate and bicarbonate alkalinity to carbonic acid, which breaks down to carbon dioxide and water. Then, the carbon dioxide may be removed by air stripping in a degasification tower. After degasification, a percentage of the raw well water containing alkalinity may be blended to obtain the desired 500 milligrams per liter of total dissolved solids.

Ion-Exchange Engineering Data

Since total dissolved solids only need to be reduced approximately 40 percent, consider low acid regeneration levels. Regeneration levels of 5 and 3 pounds per cubic foot will be considered. Leakage can be estimated from vendor data such as figure A-14.

With a 5-pound H_2SO_4 (66 degrees Be)/cubic foot regeneration level, the average sodium leakage equals 60.5 parts per million as $CaCO_3$. The capacity of the ion-exchange resin can be found in figure A-15.

With a 5-pound H_2SO_4 (66 degrees Be)/cubic foot regeneration level, the book capacity = 15.1 kilograins/cubic foot. The alkalinity correction factor can be found in figure A-16.

At 56 percent, the alkalinity correction factor is 1.125

The corrected capacity = 17.0 kilograins/cubic foot.

Then

Use equipment factor = 0.8

∴ Design Capacity = 13.6 kilograins/cubic foot.

With a 3-pound H_2SO_4 (66 degrees Be)/cubic foot regeneration level, the average sodium leakage = 104.5 parts per million as $CaCO_3$. Leakage can be estimated from vendor data such as figure A-17.

With a 3-pound H_2SO_4 (66 degrees Be)/cubic foot regeneration level, the book capacity = 11.0 kilograins/cubic foot. The capacity of the ion-exchange resin can be found in figure A-18.

AVERAGE ANALYSIS

% Na = 89
 T.C. = 550
 % ALK = 56
 % Ca = 9
 % Mg = 2

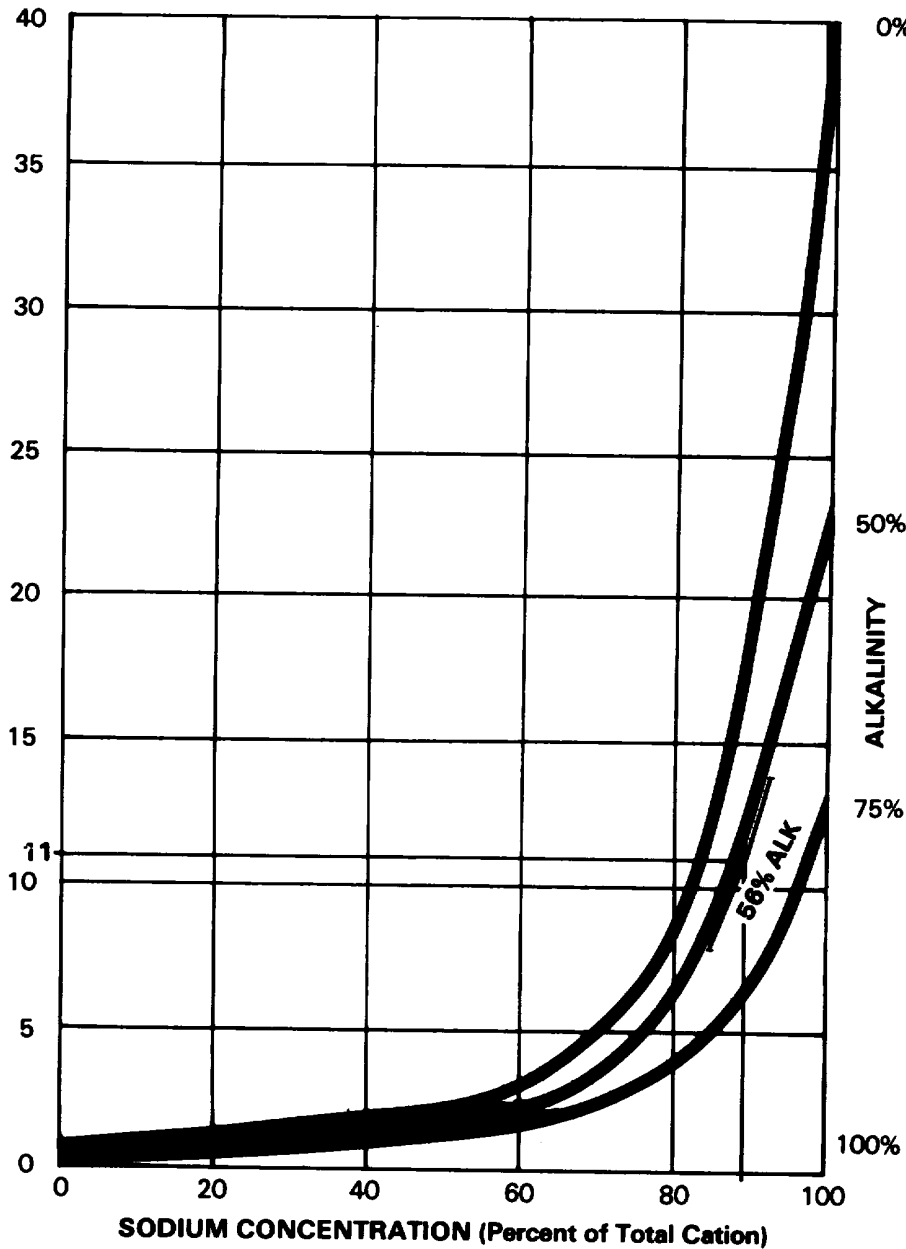

AVG. Na LEAKAGE = 0.11 × 550 = 60.5 ppm as CaCO₃

Source: Rohm and Haas Co.

Figure A-14. Amberlite IR-120 plus leakage data regeneration-5 lbs. H₂SO₄ (66° Be)/cu. ft.

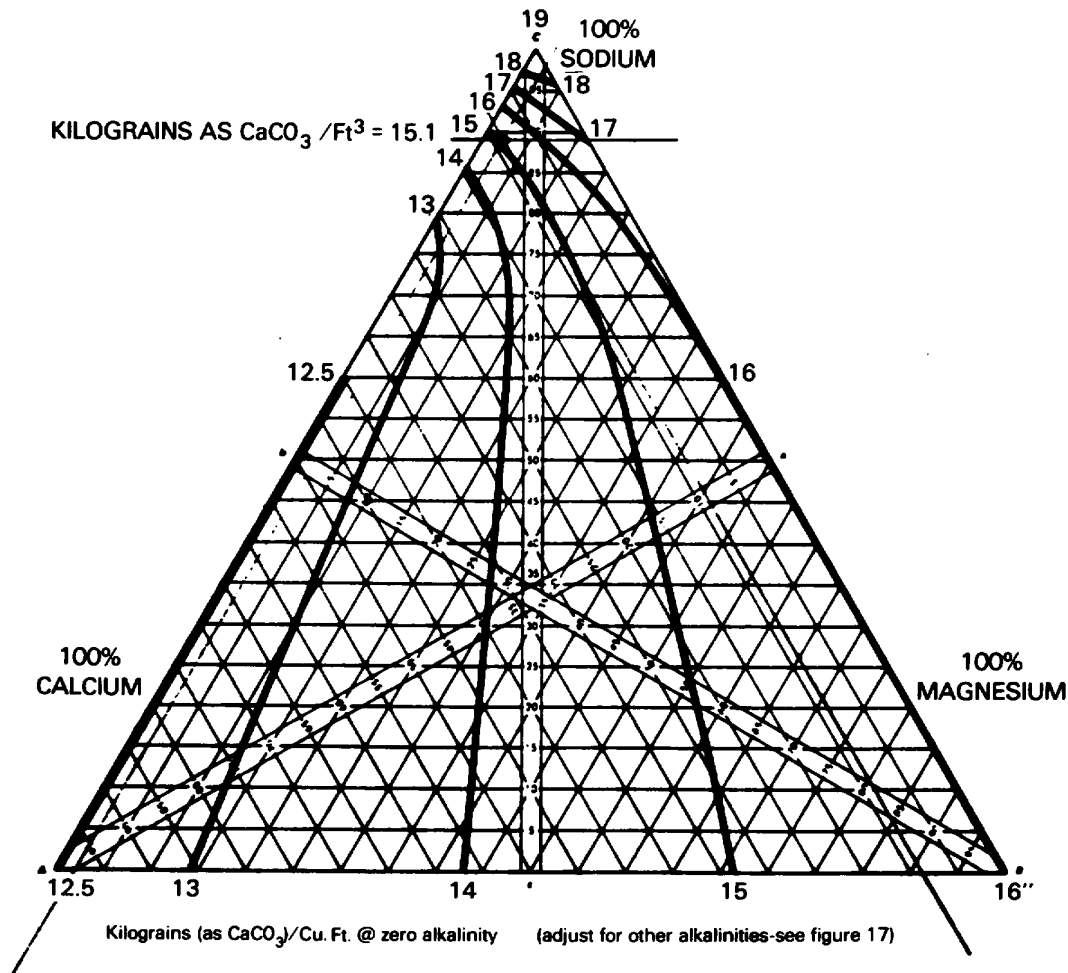

Source Rohm and Haas Co

Figure A-15. Amberlite IR-120 plus iso-capacity data regeneration-5 lbs. H₂SO₄ (66° Be)/cu. ft.

With a 5-pound H₂SO₄ (66 degrees Be)/cubic foot regeneration level, the book capacity = 15.1 kilograins/cubic foot. The alkalinity correction factor can be found in figure A-19.

Then

The corrected capacity = 12.4 kilograins/cubic foot.

Then

Use equipment factor = 0.8.

∴ Design Capacity = 9.9 kilograins/cubic foot.

Water Analyses Summary

Table A-1 is a summary of the average water constituents at different stages in the ion-exchange treatment process.

@ 56% ALK = $15.1 \times 1.125 = 17.0 \text{ KGR/Ft}^3$

USE 0.8 EQUIPMENT FACTOR
 $17.0 \times 0.8 = 13.6 \text{ KGR/Ft}^3$
 DESIGN CAPACITY

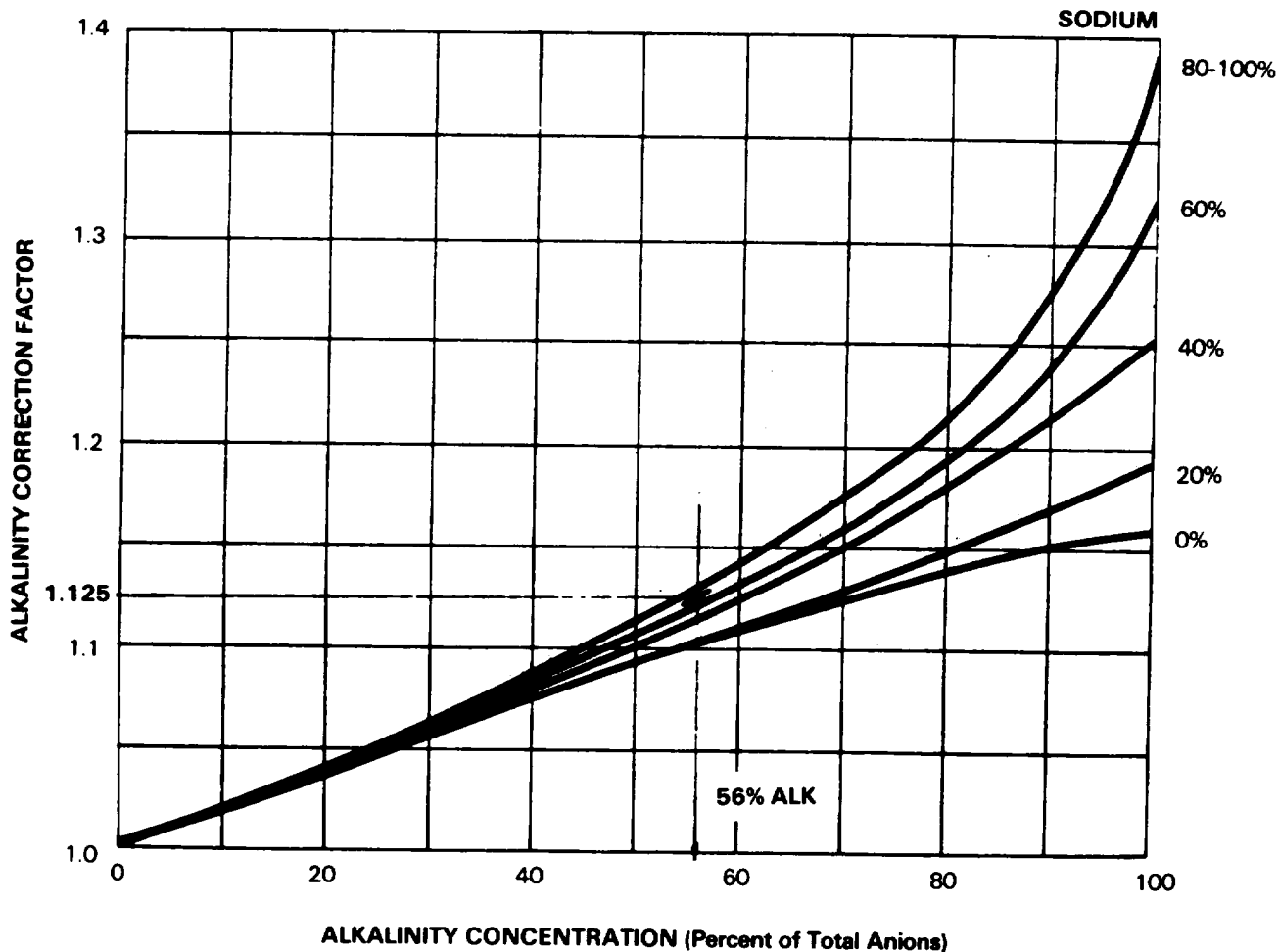

Source: Rohm and Haas Co.

Figure A-16. Amberlite IR-120 plus capacity correction for alkalinity.

When using 5-pound H₂SO₄ (66 degrees Be) per cubic foot regeneration, the cation exchanger effluent will have approximately zero calcium and magnesium, with a sodium leakage of 61 parts per million as indicated on Figure A-14. The remaining cations are hydrogen as indicated.

The anions are not affected, with the exception of alkalinity, which is converted to carbon dioxide and water.

The next step in the treatment is blending sufficient raw water to neutralize the hydrogen ions in the cation effluent.

AVERAGE ANALYSIS

% Na = 89
 T.C. = 550
 % ALK = 56
 % Ca = 9
 % Mg = 2

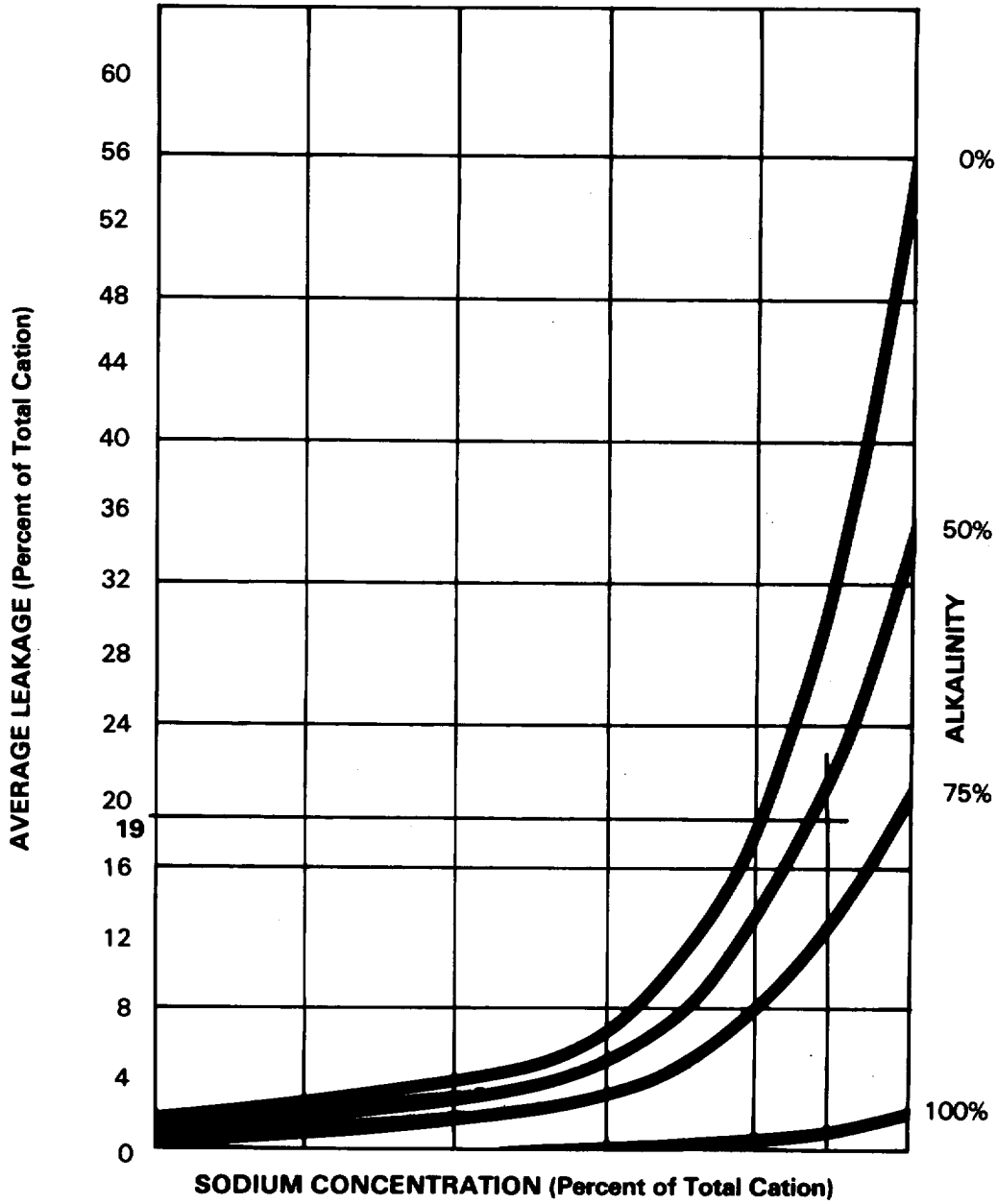

AVG. Na LEAKAGE = 0.19 × 550 = 104.5 PPM as CaCO₃

Source: Rohm and Haas Co.

Figure A-17. Amberlite IR-120 plus leakage data regeneration-3 lbs. H₂S₄ (66° Be)/cu. ft.

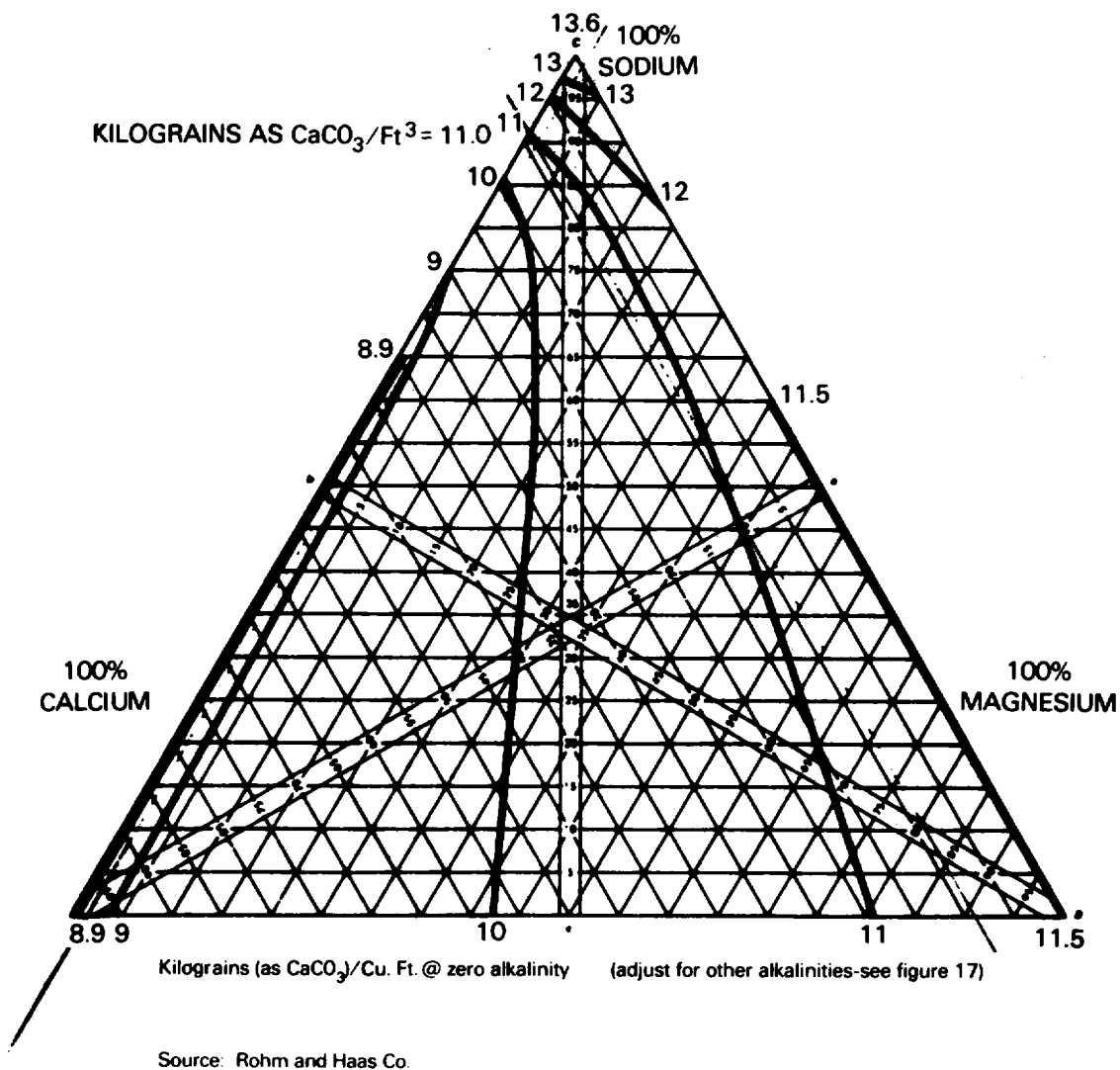

Figure A-18. Amberlite IR-120 plus iso-capacity data regeneration-3 lbs. H₂SO₄ (66° Be)/cu. ft.

Neutralized Blend (N.B.)

$$\frac{181 \text{ parts per million hydrogen as CaCO}_3}{308 \text{ parts per million alkalinity as CaCO}_3} = 0.59 \text{ Volume Ratio}$$

Or
Per unit volume of cation effluent, 0.59 volume of raw water is required to neutralize the hydrogen ions.

$$\frac{0.59}{1.59} = .37 \times 100 = 37 \text{ percent of neutralized blend is raw water}$$

- Raw Water = R.W.
- Neutral Blend = N.B.
- Potable = P

@ 56% ALK = 11.0 x 1.125 = 12.4 KGR/Ft³

USE 0.8 EQUIPMENT FACTOR

12.4 x 0.8 = 9.9 KGR/Ft³

DESIGN CAPACITY

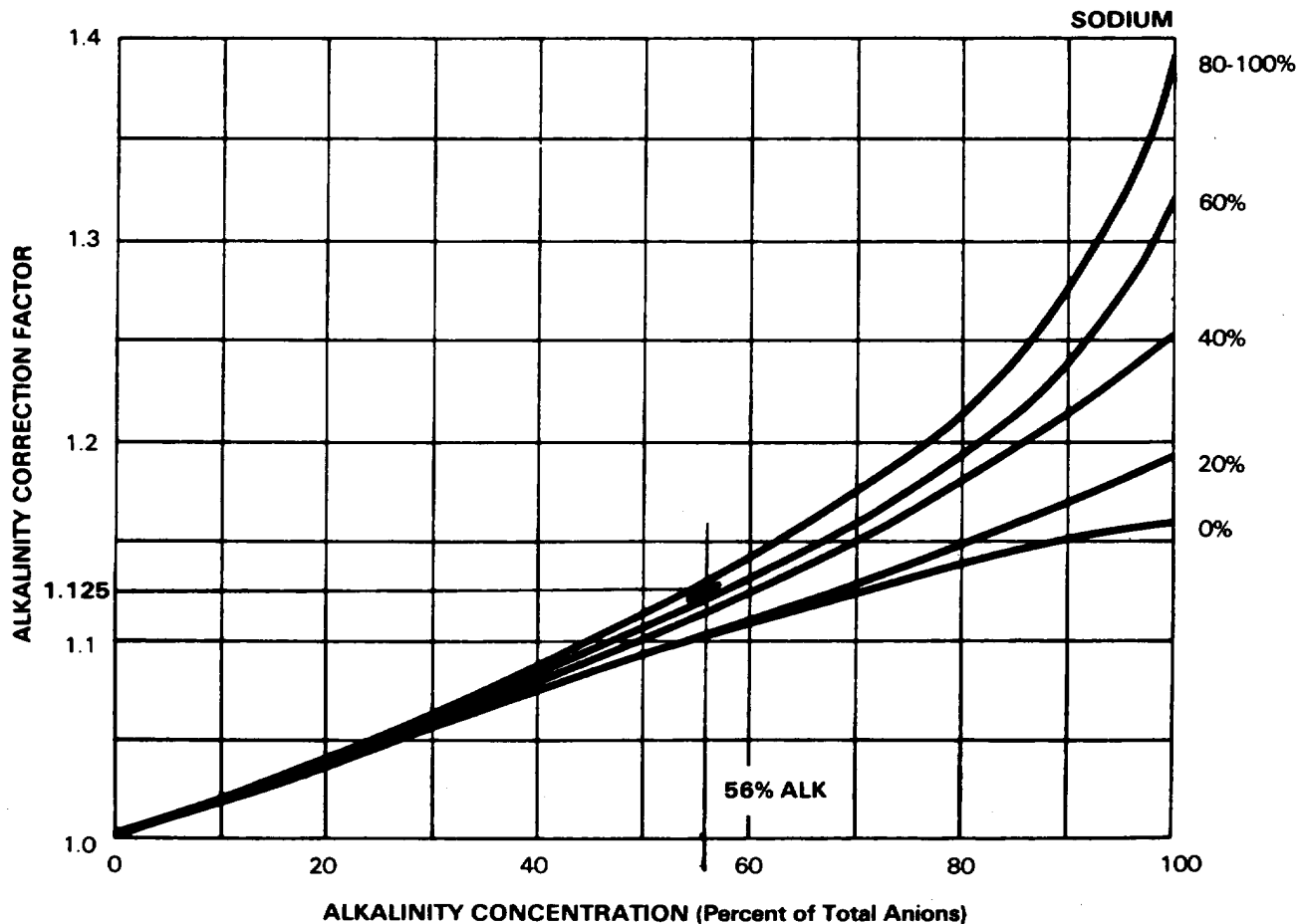

Source: Rohm and Haas Co.

Figure A-19. Amberlite IR-120 plus capacity correction for alkalinity.

100x = percent of R.W. in P
P - N.B.

$$x = \frac{P - N.B.}{R.W. - N.B.}$$

$$= \frac{500 - 303}{800 - 303} = \frac{197}{497} = 0.396$$

100x = 0.396

x = 39.6 percent R.W. in P.

100x(1 - .396) = 60.4 percent N.B. in P.

The blended potable water has a Langelier Index of + 0.65, which produces a slight scaling tendency for distribution system corrosion protection.

	Raw		Cation Effluent		(Degased) Neutralized Blend		500 Total Dissolved Solids	
	Ion	CaCO ₃	Ion	CaCO ₃	Ion	CaCO ₃	Ion	CaCO ₃
Ca	20	50	0	0	7.5	18.5	12	31
Mg	3	12	0	0	1	4.5	2	7.5
Na	225	488	28	61	101	219	150	325.5
H				181				
Total Cations		550		242		242		364
HCO ₃	324	266	0	0	0	0	141	116
CO ₃	25	42	0	0	0	0	4	6
SO ₄	77	80	77	80	77	80	77	80
Cl	107	151	107	151	107	151	107	151
NO ₃	9	11	9	11	9	11	9	11
Total Anions		550		242		242		364
pH	8.5						9.0	
Total Dissolved Solids	800				303		502	
*CO ₂ by Design					* 10	* 11	0	0
CO ₂ EQ. WT. = 44								

500 TOTAL DISSOLVED SOLIDS WATER

$Ca = (50 \times .396) + (18.5 \times .604) = 30.9$
 $Mg = (12 \times .396) + (4.5 \times .604) = 7.47$ Langelier Index = +0.65
 $Na = (488 \times .396) + (219 \times .604) = 325.52$
 $HCO_3 = (266 \times .396) +$ = 105 + 11 parts per million CO₂ as CaCO₃ = 116
 $CO_3 = (42 \times .396)$ = 16.6 - 11 parts per million CO₂ as CaCO₃ = 5.6

Table A-1. Water Constituents at Treatment Stages with 5 Pounds/Cubic Foot Acid Regeneration.

	Raw		Cation Effluent		(Degased) Neutralized Blend		500 Total Dissolved Solids	
	Ion	CaCO ₃	Ion	CaCO ₃	Ion	CaCO ₃	Ion	CaCO ₃
Ca	20	50	0	0	6	16	12	30
Mg	3	12	0	0	1	4	2	7
Na	225	488	48	104.5	102	222	151	328
H				137.5				
Totals Cations		550		242				
HCO ₃	324	266	0	0	0	0	143	117
CO ₃	25	42	0	0	0	0	4	6
SO ₄	77	80	77	80	77	80	77	80
Cl	107	151	107	151	107	151	107	151
NO ₃	9	11	9	11	9	11	9	11
Total Anions		550		242				
pH	8.5						8.9	
Total Dissolved Solids	800				302		505	
*CO ₂ by Design					* 10	* 11		
CO ₂ EQ. WT. = 44								

500 TOTAL DISSOLVED SOLIDS WATER

$$\begin{aligned} \text{Ca} &= (50 \times .398) + (16 \times .602) = 29.53 \\ \text{Mg} &= (12 \times .398) + (4 \times .602) = 7.18 \\ \text{Na} &= (488 \times .398) + (222 \times .602) = 327.87 \\ \text{HCO}_3 &= (266 \times .398) + 11 \text{ parts per million CO}_2 \text{ as CaCO}_3 = 116.87 \\ \text{CO}_3 &= (42 \times .398) - 11 \text{ parts per million CO}_2 \text{ as CaCO}_3 = 5.72 \end{aligned}$$

Langelier Index = +0.54

Table A-2. Water Constitutes at Treatment Stages with 3 Pounds/Cubic Foot Sulfuric Acid Regeneration

Source U S Army Corps of Engineers

Table A-2 is a summary of the average constituents at different stages in the ion-exchange treatment process. When using 3-pounds H₂SO₄ (66 degrees Be) per cubic foot regeneration, the cation exchange effluent will have approximately zero calcium and magnesium, with a sodium leakage of 104.5 parts

per million as indicated on figure A-17. The remaining cations are hydrogen as indicated.

After degasification of the neutral blend, the carbon dioxide is 10 parts per million based on the degasifier design. Raw water is again blended after degasification to achieve a 500 milligram per liter of total dissolved solids product.
Neutralized Blend (N.B.)

137.5 parts per million hydrogen as CaCO₃ 0.45 volume ratio
308 parts per million alkalinity as CaCO₃

Or

0.45 Volume

1.45 Volume = 0.32 x 100 = 32 percent of neutralized blend is raw water

Two-step blending is considered to take advantage of the carbonate in the raw water, which will neutralize the remaining carbon dioxide and reduce potential corrosion in the distribution system.

Blend of Well Water and Neutral Degased Water

R.W. = 800 milligrams per liter of Total Dissolved Solids

N.B. = 302 milligrams per liter of Total Dissolved Solids

P = 500 milligrams per liter of Total Dissolved Solids

100x = Percent of R.W. in P

$$= \frac{P - N.B.}{R.W. - N.B.}$$

$$x = \frac{500 - 302}{800 - 302} = 0.398$$

$$100x = 0.398$$

$$x = 39.8 \text{ R.W. in P}$$

$$100x (1 - .398) = 60.2 \text{ percent of N.B. in P}$$

The blended potable water has a Langelier Index of +0.54, which indicates a slight scaling tendency for the distribution system corrosion protection.

Chemical Requirements

3 pounds/cubic foot regeneration level

∴ In 1,000 gallons of potable water

398 gallons of raw water to 500 total milligrams per liter of dissolved solids

+ (1,000 - 398) x .32 = 193 gallons to neutralize

Or

398 + 193 = 591 gallons of raw water and 409 gallons of cation effluent

So

40.9 percent of potable water is treated with the cation exchanger.

Acid Usage

Cation Regeneration Efficiency

$$\frac{50 \text{ grains CaCO}_3 \times (3 \text{ pounds/cubic feet}) (.93 \text{ pounds acid/pounds}) (7 \text{ kilograins/pounds})}{49 \text{ grains H}_2\text{SO}_4 \quad 9.9 \text{ kilograins/cubic feet}} = 2.01$$

or 200-percent stoichiometric

Cations Removed Per Gallons of Potable Water

$$\frac{(409 \text{ gallons})}{\text{kilogallon}} \times \frac{488 \text{ parts per million} - 104.5 \text{ parts per million}}{17.1 \text{ parts per million/grains/gallon}} \times \frac{1 \text{ pound}}{7000 \text{ grains}}$$

$$= \frac{1.31 \text{ pounds as CaCO}_3}{1000 \text{ gallons potable water}}$$

At 200-percent regeneration efficiency:

$$\text{Acid Required} = 2.0 \times \frac{1.31 \text{ pounds as CaCO}_3}{\text{kilogallons potable water}} \times \frac{49 \text{ equivalent weight acid}}{50 \text{ equivalent weight CaCO}_3}$$

$$\times \frac{1 \text{ pound H}_2\text{SO}_4}{.995 \text{ percent H}_2\text{SO}_4}$$

$$= 2.58 \text{ pounds } 99.5 \text{ percent H}_2\text{SO}_4 \text{ per } 1000 \text{ gallons potable water}$$

Waste Acid

$$(2.0 - 1.0) \frac{1.29 \text{ pounds acid}}{\text{kilogallons potable water}} \times 1.29 \frac{\text{pounds } 99.5 \text{ percent H}_2\text{SO}_4}{1000 \text{ gallons potable water}}$$

Chemical Costs

Acid Cost = 3 cents/pound 99.5 percent H₂S₀4
 NaOH Cost = 10 cents/pound 100 percent NaOH
 Regeneration Acid = 1.29 pounds 99.5 percent H₂S₀4
 If neutralization of the waste acid is required prior to disposal:
 Waste Acid = $\frac{1.29 \text{ pounds } 99.5 \text{ percent H}_2\text{SO}_4}{1000 \text{ gallons potable water}}$
 If we use 100 percent NaOH
 NaOH = 1.32 pounds of 100% acid as CaCO₃ x $\frac{40 \text{ equivalent weight NaOH}}{50 \text{ equivalent weight CaCO}_3}$
 = $\frac{1.05 \text{ pounds of } 100 \text{ percent NaOH}}{1000 \text{ gallons potable water}}$

Summary of Cost Per 1000 Gallons of Potable Water

Cation exchange acid usage = 1.29 pounds x 3.0 cents = 3.87 cents
 Waste acid = 1.29 pounds x 3.0 cents = 3.87 cents
 Neutralization NaOH = 1.05 pounds x 10 cents = 10.5 cents

5 Pounds/Cubic Foot Regeneration Level

∴ In 1000 gallons potable water
 396 gallons raw water to 500 milligrams per liter of total dissolved solids + (1000 - 396) x .37 = 223.5 gallons to neutralization
 Or
 396 + 223.5 = 619.5 gallons of raw water
 And
 380.5 gallons of cation effluent
 So:
 38 percent of potable water is treated with the cation exchanger

Acid Usage

Cation Regeneration Efficiency

$$\frac{50 \text{ Equivalent Weight CaCO}_3}{49 \text{ Equivalent Weight H}_2\text{SO}_4} \times \frac{(5 \text{ pounds/cubic feet}) (.93 \text{ pounds acid/pound}) (7 \text{ kilograins/pound})}{13.6 \text{ kilograins/cubic feet}} = 2.44$$

or 250 percent stoichiometric

Cations Removed

$$\frac{380.5 \text{ gallons}}{\text{kilogallon potable water}} \times \frac{488 \text{ parts per million} - 61 \text{ parts per million}}{17.1 \text{ parts per million/grains/gallon}} \times \frac{1 \text{ pound}}{7000 \text{ grains}} = \frac{1.36 \text{ pounds as CaCO}_3}{1000 \text{ gallons potable water}}$$

At 250 Percent Regeneration Efficiency:

Acid Required

$$= 2.5 \frac{1.36 \text{ pounds as CaCO}_3}{1 \text{ kilogallon potable water}} \times \frac{49 \text{ equivalent weight acid}}{50 \text{ equivalent weight CaCO}_3} \times \frac{1 \text{ pound H}_2\text{SO}_4}{.995 \text{ percent H}_2\text{SO}_4}$$

$$= 3.35 \frac{\text{pounds 99.5 percent H}_2\text{SO}_4}{1000 \text{ gallons potable water}}$$

Waste Acid

$$(2.5-1.0) \times 1.34 = 2.01 \text{ pounds acid/1000 gallons potable water}$$

Chemical Costs

Acid Cost = 3 cents/pound 99.5 percent H₂SO₄

NaOH Cost = 10 cents/pound 100 percent NaOH

$$\text{Regeneration Acid} = \frac{1.34 \text{ pounds 99.5 percent H}_2\text{SO}_4}{1000 \text{ gallons potable water}}$$

If neutralization of the waste acid is required prior to disposal:

$$\text{Waste acid} = \frac{2.01 \text{ pounds 99.5 percent H}_2\text{SO}_4}{1000 \text{ gallons potable water}}$$

If we use 100 percent NaOH

$$\text{NaOH} = 2.04 \text{ pounds of 100\% acid as CaCO}_3 \times \frac{40 \text{ equivalent weight NaOH}}{50 \text{ equivalent weight CaCO}_3}$$

$$= 1.63 \frac{\text{pounds of 100 percent NaOH}}{1000 \text{ gallons potable water}}$$

Summary of Cost per 1000 Gallons of Potable Water

Cation exchange acid usage = 1.34 pounds x 3.0 cents = 4.02 cents

Waste acid = 2.01 pounds x 3.0 cents = 6.0 cents

Neutralization NaOH = 1.63 pounds x 10 cents = 16.3 cents

These chemical costs and water quantities can now be used for life cycle costing of the system.

The ion-exchange equipment size and cost will vary with the cation-exchange flow rate and loading.

The traded water quantities are:

Potable water requirement 450,000 gallons per day

With 5 pounds/cubic foot regeneration, 38 percent of the potable water is treated by ion exchange = 171,000 gallons per day.

With 3 pounds/cubic foot regeneration, 40.9 percent of the potable water is treated by ion exchange = 184,050 gallons per day.

Figures A-20 and A-21 show the plan view of two cation exchangers and a degasifier, respectively, similar to the equipment that will be necessary for such an ion-exchange system.

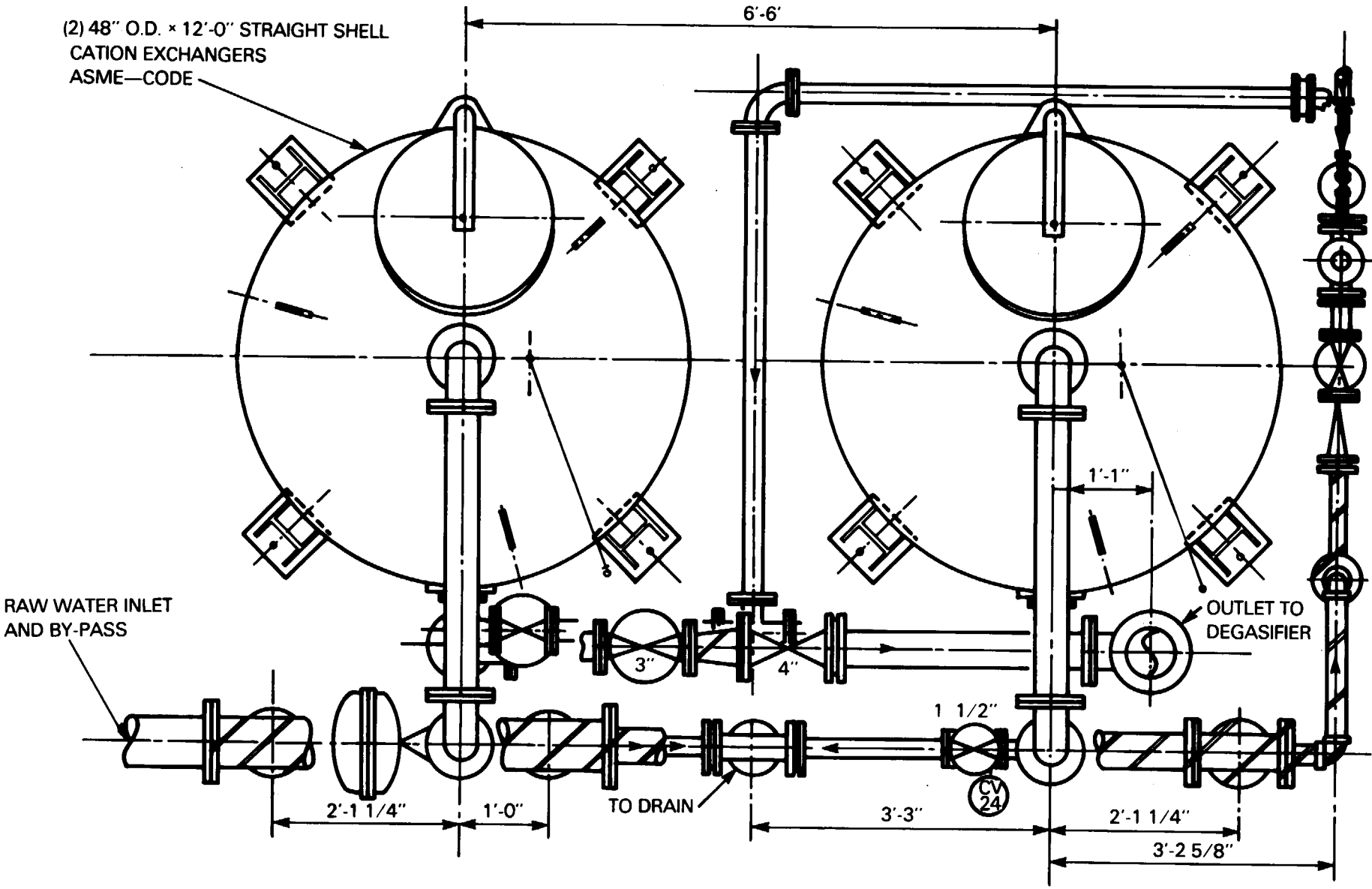
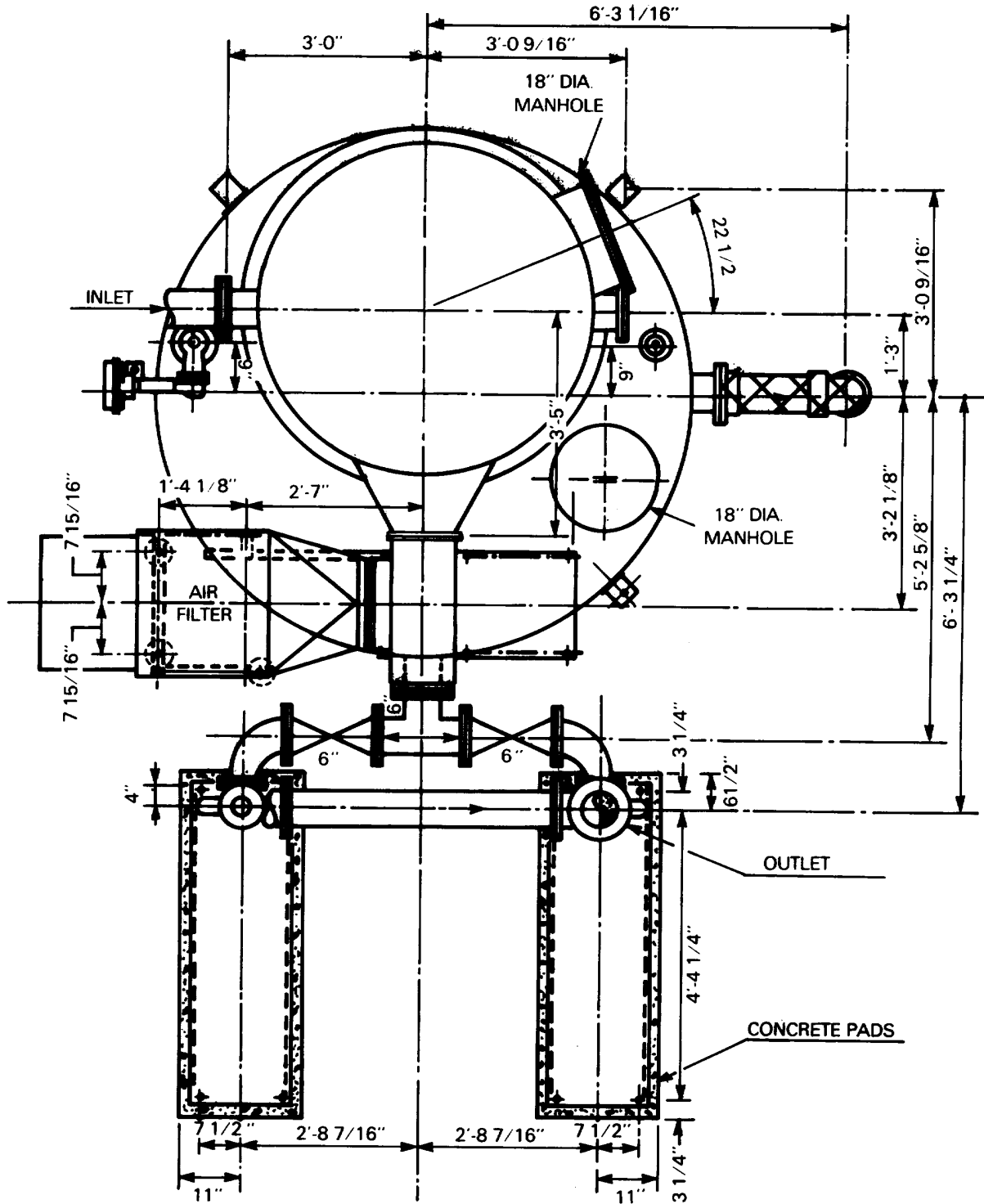

Figure A-20. Cation exchangers plan



Source: Hungerford & Terry, Inc.

Figure A-21. Degasifier and clearwell plan.

A-5. Sample of multiple component water blend optimization. A base on a volcanic island in the Pacific is to be expanded. While inadequate disinfection has often been blamed for the maladies of newcomers, the analysis requested before pumping and drilling tests are continued indicate a hard, high total dissolved solids, sulfate-rich fresh water lens on the island. For these reasons you have been assigned to direct a study to evaluate the various desalination options. You have good reason to believe that both water quantity and brine disposal will prevent the simple desalination of island well water to supply the projected 500 gallons per minute of potable water. A product-staged or double-pass reverse osmosis sea water desalination facility will apparently be required.

- Symbols: x = The flow rate of fully treated relatively pure second-stage reverse osmosis product water used in the blend.
 y = The flow rate of the first-stage reverse osmosis product water used to blend.
 z = The flow rate of island well water used to blend.
 C_x = The unit cost of second-stage reverse osmosis water (water x).
 C_y = The unit cost of first-stage reverse osmosis product water (water y).
 C_z = The unit cost of island well water (water z).
 C = The unit cost of final blended water.

SAMPLE PROBLEM ON BLENDING

Given: The high quality two-pass water (water x) contains:

- 50.0 mg Cl⁻/liter
- 1.2 mg SO₄⁼/liter
- and 95.5 mg TDS/liter

The single-pass water (water y) contains:

- 500 mg Cl⁻/liter
- 30 mg SO₄⁼/liter
- 85 mg TDS/liter

The well water presently being used (water z) contains:

- 30 mg Cl⁻/liter
- 400 mg SO₄⁼/liter
- 729 mg TDS/liter

The final blend must meet TB MED 576 standards or

- Cl⁻ ≤ 250 mg Cl⁻/liter
- SO₄⁼ ≤ 250 mg SO₄⁼/liter
- TDS ≤ 500 mg TDS/liter

$i=n$

$$\sum_{i=1} \text{Flow}_i \text{ Concentration}_i \div \text{Flow Total} = \text{Final Concentration}$$

$$\sum_{i=1} \text{Flow}_i \text{ Cost}_i/\text{Gallon} \div \text{Flow Total} = \text{Final Unit Water Cost} = C$$

Step 1: List Equations

- a. Water Balance
 $x + y + z = 500$
- b. Blend Concentration Constraints
 Chloride $50x + 500y + 30z \leq 500(250)$
 Sulfate $1.2x + 30y + 400z \leq 500(250)$
 Total Dissolved Solids
 $95.5 + 851y + 729z \leq 500(500)$

c. Two-Way Blends

for Chloride

$$500y + 50x \leq 250(500)$$

$$x = 500 - y$$

$$\therefore 500y + 50(500) - 50y \leq 250(500)$$

$$\text{or } y \leq 500(250 - 50)/(500 - 50)$$

for Total Dissolved Solids

$$851y + 95.5x \leq 500(500)$$

$$x = 500 - y$$

$$\therefore 851y + 95.5(500) - 95.5y \leq 500(500)$$

$$\text{or } y \leq 500(500 - 95.5)/(851 - 95.5)$$

For sulfate, neither water y nor x are limited.

for Sulfate

$$400z + 1.2x \leq 250(500)$$

$$x = 500 - z$$

$$\therefore 400z + 1.2(500) - 1.2z \leq 250(500)$$

$$\text{or } z \leq 500(250 - 1.2)/400 - 1.2$$

for Total Dissolved Solids

$$792z + 95.5x \leq 500(500)$$

$$x = 500 - z$$

$$\therefore 792z + 95.5(500) - 95.5z \leq 500(500)$$

$$\text{or } z \leq 500(500 - 95.5)/(729 - 95.5)$$

For Chlorides, neither water x nor z are limited.

d. Cost

$$C_x x + C_y y + C_z z = C$$

Step 2: Project constraints onto water balance equation to eliminate one variable (preferably the most expensive water).

a. Chloride $50x + 500y + 30z \leq 125,000$

$$\underline{-50x - 50y - 50z = -25,000}$$

$$450y - 20z \leq 100,000$$

b. Sulfate $1.2x + 30y + 400z \leq 125,000$

$$\underline{-1.2x - 1.2y - 1.2z = -600}$$

$$28.8y + 398.8z \leq 124,400$$

c. Total Dissolved Solids $95.5x + 851y + 729z \leq 250,000$

$$\underline{-95.5x - 95.5y - 95.5z = -47,750}$$

$$755.5y + 633.5z \leq 202,250$$

Step 3: Graph resulting constraint questions, two dimensions at a time in the M dimensional space required (i.e., for blending 10 waters, all combinations of 9 things taken two at a time; for this example of 3 waters all combinations of 2 things taken two at a time). See figure A-22.

Step 4: Solve all constraints simultaneously to identify corners and edges. The most economical blend will almost always occur at a corner, but it is possible that an entire range of blend values along a constraint edge will be equally economical.

a. Chloride - Sulfate Pair

$$SO_4^{=} = 28.8y + 398.8z \leq 124,400$$

$$\underline{(398.8/20)Cl^- = 8973.0y - 398.8z \leq 1,994,000}$$

$$9001.8y \leq 118,400$$

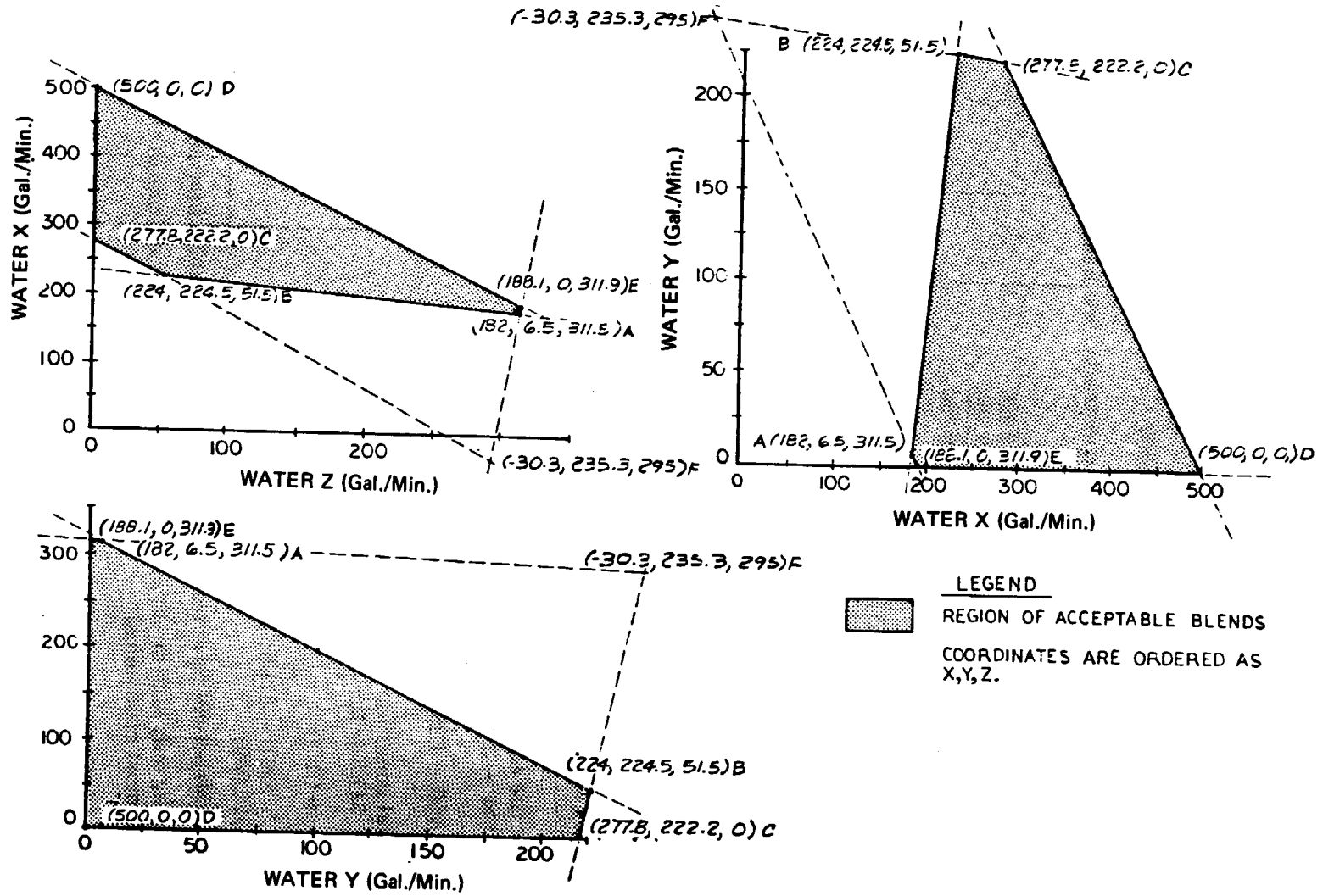

Figure A-22. Three projections of the water blends that satisfy TB MED 576 Requirements.

$$y \leq 235.3$$

$$z \leq [124,400 - 28.8(235.3)]/398.8$$

$$z \leq 295$$

$$x \leq 500 - 235.3 - 295 = -30.3$$

but the Total Dissolved Solids in this corner is:

$$-30.3(95.5) + 235.3(851) + 295(729) \leq 250,000$$

$$412,401.65 \leq 250,000$$

Therefore, this corner is outside of the TDS constraint. See figure A-22 point F.

b. Total Dissolved Solids - Chloride Pair

$$\text{Total Dissolved Solids } 755.5y + 633.5z \leq 202,250$$

$$\frac{(633.5/20)\text{Cl}^-}{15,009.25y} = \frac{14,253.75y - 633.5z}{15,009.25y} \leq \frac{3,167,500}{15,009.25y}$$

$$15,009.25y \leq 3,369,750$$

$$y \leq 224.5$$

$$z \leq [202,250 - 755.5(224.5)]/633.5$$

$$z \leq 51.5$$

$$x \leq 500 - 224.5 - 51.5 = 224$$

and for Sulfate SO_4^{2-} ;

$$224(1.2) + 224.5(30) + 51.5(400) \leq 125,000$$

$$27,603.8 \leq 125,000$$

Therefore, this blend will have less than the maximum allowable sulfate concentration.

c. Total Dissolved Solids - Sulfate Pair

$$\text{Total Dissolved Solids } 755.5y \leq 202,250 - 633.5z$$

$$\frac{(755.5/28.8)\text{SO}_4^{2-}}{-755.5y} = \frac{-755.5y \leq 3,263,340.3 - 10,461.6z}{-755.5y}$$

∴ solving for the equal condition only

$$202,250 - 633.5z = 3,263,340.3 - 10,461.6z$$

$$z = 311.5$$

$$y \leq [202,250 - 633.5(311.5)]/755.5$$

$$y \leq 6.5$$

using the equal condition makes $z \leq 311.5$

$$x \geq 500 - 311.5 - 6.5 = 182$$

and for chloride Cl^-

$$182(50.0) + 6.5(500) + 311.5(30) \leq 125,000$$

$$21,695 \leq 125,000$$

Therefore, this blend will have less than the maximum allowable chloride Cl^- concentration.

Blends containing only high quality second-stage product water and one of the remaining waters x or y could be most economical.

d. Well Water z and Water x

1. Sulfate limited
 - $z \leq 500 (250 - 1.2)/(400 - 1.2)$
 - $z \leq 311.9$ so $x \geq 188.1$
2. TDS limited
 - $z \leq 500(500 - 95.5)/729 - 95.5)$
 - $z \leq 319.25$ so $x \geq 180.75$
3. Chloride cannot limit since both have chlorides below 250.

e. Single-Pass Reverse Osmosis Water y and Water x.

1. Chloride limited
 $y \leq 500 (250 - 50.0)/(500 - 50.0)$
 $y \leq 222.2$ so $x \geq 277.8$
2. TDS limited
 $y \leq 500(500 - 95.5)/(851 - 95.5)$
 $y \leq 267.7$ so $x \geq 232.3$
3. Sulfate cannot limit since both waters have sulfates below 250. (The intercept at 4319.4 would require a removal flow of -3819.4 of second-stage product water x to concentrate the split stream to 250 mg SO₄/liter.)

f. Locate Inside Intercepts

1. Since $311.9 \leq 319.25$,
 Sulfate limits use of water
 z to $z \leq 311.9$ with
 $x \geq 188.1$
2. Since $222.2 \leq 267.7$,
 Chloride limits use of water
 y to $y \leq 222.2$ with
 $x \geq 277.8$

Step 5: Identify the coordinates of the corners of the convex polyhedron of acceptable blends. In this case, the polyhedron is a pentagon with 5 corners. The coordinates of the corners of acceptability are:

	x	y	z
1-	500	0	0
2-	577.8	222.2	0
3-	188.1	0	311.9
4-	182	6.5	311.5
5-	224	224.5	51.5

Step 6: Use Cost Equation to make each corner and edge a minimum cost solution (use the graph to identify adjacent corners).

a. All Second-Stage Product (No Blending)

$C_x 500 \leq 188.1 C_x + 311.9 C_z$
 and $C_x 500 \leq 277.8 C_x + 222.2 C_y$
 Therefore, don't blend at all if $C_x \leq C_z$ and $C_x \leq C_y$

b. Blend of x and y Waters Only

$500C_x \geq 222.2 C_x + 277.8 C_y$ and $222.2 C_x + 277.8 C_y \leq 224 C_x + 224.5 C_y + 51.5 C_z$

or $C_x \geq C_y$
 and $53.8 C_x \leq 2.3 C_y + 51.5 C_z$
 or $C_x \leq 0.0427 C_y + 0.95725 C_z$

Therefore, if the cost of water x was greater than the cost of water y, and less than $0.0427 C_y + 0.957 C_z$ then the blend of single- and double-pass sea water reverse osmosis products would be more economical than any blend containing well water.

c. Blend of x and z Water Only

$500 C_x \geq 188.1 C_x + 311.9 C_z$ and $188.1 C_x + 311.9 C_z \leq 182 C_x + 6.5 C_y + 311.5 C_z$

or $C_x \geq C_z$
 and $6.1 C_x + .4 C_z \leq 6.5 C_y$
 or $C_x \leq 1.066 C_y - 0.066 C_z$

Therefore, if the cost of water x was greater than the cost of water z, but less than $1.066 C_y - 0.066 C_z$, then the blend of well water and double-pass sea water reverse osmosis product would be more economical than any blend containing any single-pass waters.

d. Blend at Point A Figure A-22 containing a small amount of single-pass reverse osmosis water y.

$$182 Cx + 6.5 Cy + 311.5 Cz \leq 224 Cx + 224.5 Cy + 51.5 Cz \text{ and } 182 Cx + 6.5 Cy + 311.5 Cz \leq 188.1 Cx + 311.9 Cz$$

or

$$260 Cz \leq 42 Cx + 218 Cy$$

$$\text{and } 0.4 Cz \geq 6.5 Cy - 6.1 Cx$$

or

$$16.25 Cy - 15.25 Cx \leq Cz \leq 0.1615 Cx + 0.838 Cy$$

Therefore, if the cost of well water is less than $0.1615 Cx + 0.838 Cy$ and greater than $16.25 Cy - 15.25 Cx$, then the use of 6.5 gallons/minute of first-stage reverse osmosis product water in a blend to reduce the amount of second-stage product needed, to dilute well water, from 188.1 gallons/minute to 182 gallons/minute will be economical.

e. Blending at Point B Figure A-22

using 224 gallons/minute of water x

224.5 gallons/minute of water y

and 51.5 gallons/minute of water z

$$224 Cx + 224.5 Cy + 51.5 Cz \leq 182 Cx + 6.5 Cy + 311.5 Cz, \text{ and } 224 Cx + 224.5 Cy + 51.5 Cz \leq 277.8 Cx + 222.2 Cy$$

or

$$42 Cx + 218 Cy \leq 260 Cz$$

$$\text{and } 51.5 Cz \leq 53.8 Cx - 23 Cy$$

or

$$0.1615 Cx + 0.838 Cy \leq Cz$$

$$\text{and } Cz \leq 1.0447 Cx - 0.0447 Cy$$

Therefore, if the cost of well water is greater than $0.1615 Cx + 0.838 Cy$ and less than $1.0447 Cx - 0.0447 Cy$, then the use of a blend of 51.5 gallons/minute of product-staged double-pass reverse osmosis water, with 224.5 gallons/minute of first-pass reverse osmosis product water and 224 gallons/minute of well water, would be the most economical blend.

Step 7: Make Reasonable Assumptions and Worst Case Scenarios

- a. The cost of second-stage reverse osmosis product water must be greater than the cost of first-stage reverse osmosis product water, because second-stage water is made from first-stage water.
- b. The maximum recovery available with most triple-reject-staged reverse osmosis membrane module assemblies is 85%.
- c. The second-stage low-pressure desalination of first-stage product water is almost always less expensive than the initial first-stage desalination of sea water.
- d. The expansion of a drain field collection or a well field system is almost always cheaper than the desalination of even brackish water.

Step 8: Put Assumptions and Scenarios into Mathematical Form

- a. Using 2 from step 7
 $Cx > Cy$
- b. Using a and b from step 7
 $Cx \geq 1/.85 Cy = 1.176 Cy$
- c. Using c and a from step 7
 $Cx \leq 2 Cy$ usually
- d. Using d from step 7
 $C2 \leq Cy$ usually
- e. Using a and d above
 $Cx > Cy \geq Cz$ usually
- f. Using c and d above
 $1/2 Cx \leq Cy \geq Cz$ usually
- g. Using b and d above
 $.85 Cx > Cy \geq Cz$ usually

- Step 9: Analyze the Minimum Corner and Edge Constraints Solutions from Step 6 with respect to the assumptions and scenarios in Step 8.
- Since $C_x > C_y$ and for the minimum cost solution to be all double-pass water such as Case a, Step 6, $C_x > C_y$, blending should be done for economy.
 - When water x and y are the only components of a blend Case B, Step 6 shows $C_x \leq 0.0427 C_y + .957 C_z$ and Step 8, Case g shows $.85 C_x > C_y \geq C_z$
Therefore, $1.176 C_y \leq 0.0427 C_y + .957 C_z$
or $1.134 C_y < C_z$,
which violates the second half of Step 8, Case g, unless the cost of well water really is greater than 1.13 times the cost of first-stage reverse osmosis sea water desalination.
 - When water x and z are the only components of a blend Case C, Step 6 shows $C_x \leq 1.066 C_y - 0.066 C_z$ and Step 8, Case b shows $C_x > 1.176 C_y$
Therefore, $1.176 C_y < 1.066 C_y - 0.066 C_z$
or $0.11 C_y \leq -0.066 C_z$,
so this cannot be an optimum solution unless someone is paying you to dispose of well water z.
 - When 6.5 gallons/minute of first-stage reverse osmosis product water is used in a triple blend Step 6, Case d shows $16.25 C_y - 15.25 C_x \leq C_z \leq 0.1615 C_x + 0.838 C_y$ and Step 8, Case f shows $.5 C_x \leq C_y \geq C_z$ usually
Therefore,
 $16.25 C_y - 15.25(2 C_y) \leq C_z \leq 0.1615(2 C_y) + 0.838 C_y$
or $-14.25 C_y \leq C_z \leq 1.161 C_y$,
so for any cost from being paid 14.25 times the cost of water y to dispose of well water z to having water z cost 1.161 times water y the optimum cost solution will be this triple blend.
 - When the acceptable triple blend of
224 gallons/minute of water x
224.5 gallons/minute of water y
and 51.5 gallons/minute of water z
is most economical, Step 6, Case e shows $0.1615 C_x + 0.838 C_y \leq C_z \leq 1.0447 C_x - 0.0447 C_y$
and Step 8, Case f, shows $.5 C_x \leq C_y \geq C_z$ usually
and Step 8, Case g shows $.85 C_x \geq C_y \geq C_z$ usually
Therefore,
 $(0.1615)(1.176 C_y) + 0.838 C_y \leq C_z \leq 1.0447 (2 C_y) - 0.0447 C_y$
 $1.0279 C_y \leq C_z \leq 2.0447 C_y$
so this blend will be economical only if the cost of well water is greater than the cost of single-pass desalinated sea water by more than 1.03 times and less than 2.04 times as expensive as single-pass desalinated sea water. These conditions violate the second part of Step 8, Cases f and g.

Step 10: Draw Conclusions

- The most economical blending strategy on the island will almost certainly be: 182 gallons/minute of high quality second-stage, product-staged reverse osmosis desalinated sea water

6.5 gallons/minute of high chloride high total dissolved solids single-or first-stage reverse osmosis desalinated sea water. 311.5 gallons/minute of high sulfate island well water

This blend will be most economical when:

1. The cost of island well water is between 14.25 times single-or first-stage product water and 1.161 times the cost of this first-stage product water.
 2. The removal of 311.5 gallons/minute of well water does not degrade the water quality in the wells.
- b. The availability of up to 312 gallons/minute of island well water and the quality of island well water should be investigated extensively.
 - c. If over roughly $(500) + 85 = 600$ gallons/minute of island well water can easily be withdrawn without degrading the quality or quantity of island well water in the future, then the facility should be reviewed again for the installation of electro dialysis-reversal treatment at 85% recovery and disposal of the resulting high sulfate brine.
 - d. The use of a mere 6.5 gallons/minute of first-stage desalinated sea water will save at least $(188.1 - 182)$ gallons/minute = 6.1 gallons/minute of second-stage reverse osmosis water plus $(6.1) + 0.85(6.5)$ gallons/minute = 0.68 gallons/minute first-stage reverse osmosis water. This savings is definitely worth the engineering, construction, and operation costs.
 - e. A table showing the final cost of blended waters consisting of the five possible minimum cost blends of \$.10 well water, \$4.00 single-pass reverse osmosis water, and \$5.75 double-pass reverse osmosis water has been prepared and is shown in table A-3. Figure A-23 shows a plan view of the desalination system of a two pass reverse osmosis system.

A-6. Sample problem for simple blend. A base in the desert has a water with a total dissolved solids content of 907 mg TDS/liter. If reverse osmosis is to be used as a desalination technique in this application, then the final product water will have far less than the required 500 mg TDS/liter. If 250,000 gallons/day of finished water will be required, how much of the raw water can be reblended in meeting TB-MED 576 requirements?

Symbols:

x = Amount of water that must be treated

Given:

Daily flow is 250,000 gallons/day

Finished blend concentration is 500 mg TDS/liter.

Initial feed concentration is 907 mg TDS/liter.

$$\text{Flow Concentrated} = \frac{(\text{Desired Concentration} - \text{Dilute Concentration}) \text{Flow Dilute}}{(\text{High Concentration} - \text{Desired Concentration})}$$

SAMPLE PROBLEM FOR SIMPLE BLEND

Assumptions: a. The total dissolved solids rejection of a low-pressure membrane is about 90%, leaving .1 x TDS in the dilute water stream.

b. Total dissolved solids are the limiting factors in the reblending.

Therefore: The flow of raw undesalinated water used = 250,000 gallons/day - x

And:

$$(250,000 \text{ gallons/day} - x) = \frac{[500 - .1(907)]x}{(907 - 500)}$$

$$250,000 \text{ gallons/day} = x + (409.3/407)x$$

$$250,000 \text{ gallons/day} = 2.00565x$$

$$\therefore x = 124,000 \text{ gallons/day}$$

A-7. Silt density index (SDI). This fouling index mentioned in Chapter 3, tables 4-2 and 4-3, and Chapter 5 is measured on a 47-millimeter-diameter 0.45-micron pore size membrane filter. The data used by the manufacturers to calculate the index are the time (T1) necessary initially to force 500 milliliters of solution through a clean 0.45-micron filter with a 30-pound-per-square-inch pressure differential across the filter, followed by the time (T2) required to force an additional 500

Well Water Z Unit Cost = \$0.10/Gallon		Single-Pass R.O. Water Y Must Be Produced for X-0 Unit Cost = \$4.00/Gallon		Double-Pass R.O. Water X Used to Blend to Quality Unit Cost = \$5.75/Gallon		TOTAL Blended Water		
Flow of Water Z	Cost Incurred for Water Z	Flow of Water Y	Cost Incurred for Water Y	Flow of Water X	Cost Incurred for Water X	Total Cost Per/Hr	Total Flow Per/Hr	Unit Cost of Water
In Gallons/Min	In \$/Min	In Gallons/Min	In \$/Min	In Gallons/Min	In \$/Min	In \$/Min	In Gallons/Min	
0	\$ 0.00	0	\$ 0.00	500	\$2875.00	\$2875.00	500	\$5.75
0	\$ 0.00	222.2	\$888.80	277.8	\$1597.35	\$2486.15	500	\$4.97
311.9	\$31.19	0	\$ 0.00	188.1	\$1081.58	\$1112.77	500	\$2.23
311.5	\$31.15	6.5	\$ 26.00	182	\$1046.50	\$1103.65	500	\$2.21
51.5	\$51.50	224.5	\$898.00	224	\$1288.00	\$2237.50	500	\$4.48

Put
 $C_x = \$5.75/\text{Gallon}$
 $C_y = \$4.00/\text{Gallon}$
 $C_z = \$0.10/\text{Gallon}$

In Given:

Table A-3. Cost projections for possible optimum blends.

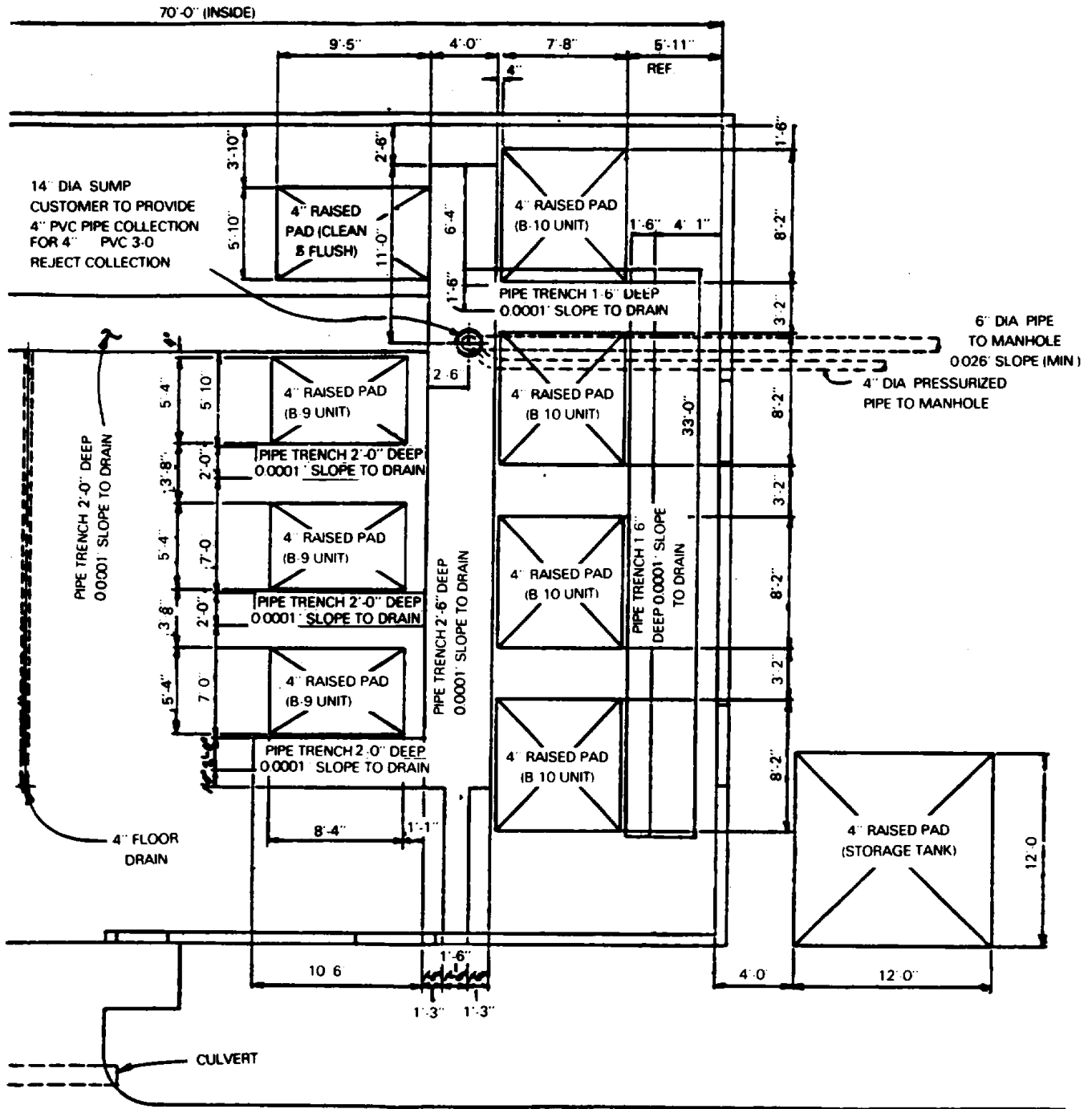

Figure A-23. Plan review of a two-pass reverse osmosis system.

Source Neptune MiroFloc Inc

milliliters of solution through the same filter (operating at the constant pressure 30 pounds per square inch gauge) 15 minutes later. Between these two time periods ($T_B = 15$ minutes) the solution must be continuously fed to the membrane filter under a constant 30-pound-per-square-inch gauge pressure differential. The silt density index is then calculated in the following manner:

Symbols:

T_1 = Time for first 0.132 gallons to pass filter

T_B = Time between two measured 500-milliliter samples, usually 15 minutes

T_2 = Time for second 500-milliliter sample to pass filter

SDI = Silt Density Index

Given:

- T = 1 minute
- T_B = 15 minutes
- T₂ = 4.083 minutes

$$\frac{(1 - T_1/T_2) \times 100}{T_B} = \text{SDI}$$

The formula for the SDI is as follows:

$$\text{SDI} = (1 - 1 \text{ minute}/4.083 \text{ minutes}) 100/15 \text{ minutes} = 5.03 \text{ silt density index}$$

A-8. Concentration factor. If the percentage of the feed stream that is removed as product water (i.e., percent recovery) is known, the concentration of the brine can be calculated for the purpose of estimating scaling concentrations as follows:

Symbols:

Percent Rec. = 100 x the fraction of the feed water that becomes product water

Given:

30 percent of the feed water becomes product

At 30 percent recovery, 70 percent of water contains all the original salt, ∴

1/0.7 x original concentration = final concentration

$$\frac{1}{1 - \text{Percent Rec.}} = \text{Concentration factor}$$

$$\frac{1}{1 - 30} = 1.429$$

A-9. Reverse osmosis membrane requirement (manufacturers will supply the necessary number of permeators).

The following equations can be used with membrane manufacturer's water flux constants to calculate a water flux or, by rearrangement of the equation, a membrane area requirement can be calculated.

Symbols:

Q_w = Water flow

K_w = Water flux constant for the membrane

A = Area of membrane

ΔP = The pressure drop across the membrane (not including head losses to or from the membrane)

Aπ = The osmotic pressure difference across the membrane

Usually about: $\frac{10 \text{ pounds per square inch}}{1,000 \text{ milligrams per liter of total dissolved solids}}$

Given:

K_w = 2.53 x 10⁻⁷ gallons/pound-hour

The membrane area, A = 1,000 square feet

The applied pressure, P = 900 pounds/square inch

The osmotic-pressure difference, Δπ = 350 pounds/square inch.

$$Q_w = K_w A (\Delta P - \Delta \pi)$$

$$Q_w = 2.53 \times 10^{-7} \text{ gallons/pound-hour} \times 1,000 \text{ square feet} \times 144 \text{ square feet} \times (900 \text{ pounds/square inch} - 350 \text{ pounds/square inch})$$

$$Q_w = 20 \text{ gallons/hour}$$

A-10. Reverse osmosis membrane salt flux (manufacturers will meet desired water quality). The following calculations can be used with membrane manufacturer's specific ion flux constants to estimate the concentrations of particular ions in the product water.

Symbols:

Q_s	= The salt flow
K_s	= The salt flux constant for the ion under consideration across the membrane used
A	= The area of membrane
$C_{ion} \text{ feed/brine average}$	= One half the sum of the feed concentration and the reject brine concentration of the ion under consideration (Mg++ in this example)
$C_{ion} \text{ product}$	= The concentration in the product of the ion under consideration (Mg++ in this example)

Given:

The salt flux constant for this membrane $K_s = 2.8 \times 10^{-4}$ gallons per square foot-hour

The membrane area $A = 1,000$ square feet

The feed water contains 204.4 grains per gallon of magnesium Mg++.

The product water contains 0.3 grains per gallon of magnesium Mg++.

$Q_s = K_s A (C_{ion} \text{ feed/brine average} - C_{ion} \text{ product})$

$Q_s = (2.8 \times 10^{-4} \text{ gallons per square foot-hour})$
 $(1,000 \text{ square feet})$
 $(204.4 \text{ grains per gallon Mg++} - 0.3 \text{ grains per gallon Mg++})$
 $= 57 \text{ grains Mg++ per hour}$

A-11. Second-law limiting thermal efficiency. A perfect conversion of heat into work is not possible. There is, however, a limiting efficiency of conversion of heat energy to mechanical or electrical energy. No heat machine can operate at this best efficiency, but it does allow a rough estimate of the value of lower grades of steam.

Symbols:

$T_H =$ Temperature in degrees Rankine of steam source. Higher temperature in degrees Rankine (degrees Rankine equal degrees Fahrenheit plus 460 degrees)

$T_L =$ Temperature in degrees Rankine of the cooling sink. Lower or discharge temperature in degrees Fahrenheit

$e_{max} =$ Maximum possible second law efficiency (maximum percent of the heat available that can be converted theoretically into work)

$$e_{max} = (T_H - T_L) / T_H \times 100$$

Given:

The steam temperature drop available is 264 degrees Fahrenheit to 68 degrees Fahrenheit. (See problem A-2.)

$$e_{max} = (724 \text{ degrees Rankine} - 528 \text{ degrees Rankine}) / 724 \text{ degrees Rankine} \times 100$$

$$e_{max} = 27 \text{ percent}$$

APPENDIX B

WATER TESTING REQUIRED FOR DESALINATION TREATMENT

TEST	PROCESS		
	<i>Electrodialysis Reversal</i>	<i>Reverse Osmosis</i>	<i>Distillation</i>
TDS	D-P	D-P	D-P
Temperature	D	D	D
Turbidity	D-P	D-P	D-P
Suspended Solids	P	P	P
Color	D-P	D-P	D-P
Corrosivity	D	D	D
Odor	P	P	P
pH	D-P	D-P	D-P
Alkalinity	D-P	D-P	D-P
Total Hardness	D-P	D-P	D-P
Noncarbonate Hardness	D-P	D-P	D-P
Carbonate Hardness	D-P	D-P	D-P
H ₂ S	D	D	D
Chlorine Demand	D	D	D
Bacterial Contamination	D-P	D-P	D-P
Plankton	D	D	D
Oil and Grease	D	D	D
Endrin	D-P	D-P	D-P
Lindane	D-P	D-P	D-P
Methoxychlor	D-P	D-P	D-P
Toxaphene	D-P	D-P	D-P
2, 4-D	D-P	D-P	D-P
2, 4, 5-TP Silvex	D-P	D-P	D-P
Trihalomethanes	P	P	P
Ammonia	D-P	D-P	D-P
Arsenic	D-P	D-P	D-P
Barium	D-P	D-P	D-P
Cadmium	D-P	D-P	D-P
Chromium	D-P	D-P	D-P
Lead	D-P	D-P	D-P
Mercury	D-P	D-P	D-P
Nitrate	D-P	D-P	D-P
Selenium	D-P	D-P	D-P
Silver	D-P	D-P	D-P
Fluoride	D-P	D-P	D-P
Zinc	D-P	D-P	D-P
Copper	D-P	D-P	D-P
Boron	D-P	D-P	D-P
Calcium	D-P	D-P	D-P
Magnesium	D	D	D
Strontium	D	D	D
Sodium	D	D	D
Potassium	D	D	D
Bicarbonate	D	D	D
Carbonate	D	D	D
Sulfate	D-P	D-P	D-P

Legend:

D = Required for desalination process design

P = Required for potable water design

TEST	PROCESS		
	<i>Electrodialysis Reversal</i>	<i>Reverse Osmosis</i>	<i>Distillation</i>
Chloride	D-P	D-P	D-P
Iron	D-P	D-P	D-P
Manganese	DP	D-P	D-P
Molybdenum Reactive			
Silica		D	
Molybdenum Nonreactive			
Silica		D	
Silt Density Index		D	

Legend:

D = Required for desalination process design

P = Required for potable water design

APPENDIX C

REFERENCES

Government Publications.*Department of Defense.*

DOD 4270.1-M

Construction Criteria Manual

Department of the Army.

AR 420-46

Water and Sewage

TB MED 229

Sanitary Control and Surveillance of Water
Supplies at Fixed and Field Installations

TB MED 576

Sanitary Control and Surveillance of Water
Supplies at Fixed Installations

TM 5-813-1

Water Supply Sources and General
Considerations

TM 5-813-3

Water Treatment

TM 5-813-4

Water Supply and Water Storage

TM 5-813-7

Water Supply Special Projects

BIBLIOGRAPHY**A. Books:**

American Chemical Society, Journal of Chemical and Engineering Data, XIII, Aqueous Systems at High Temperature, American Chemical Society, 1155 16th St. N.W., Washington, DC (January 1968).

American Public Health Association, American Water Works Association, and Water Pollution Control Federation, Standard Methods for the Examination of Water and Wastewater (15th Edition). American Public Health Association, Washington, DC (1981).

Spiegler, K. S., and A. D. K. Laird, Principles of Desalination (2nd Edition). Parts A and B. Academic Press, New York (1980).

B. Manuals:

Desalting Handbook for Planner OWRT-8701 (1) NTIS PB80-202518. Office of Water Research and Technology and Catalytic, Inc. (1979).

Electrical Design Corrosion Control TM 5-811-4. Department of the Army (1962).

Installation Master Planning Principles and Procedures TM5-803-1. Department of the Army (1970).

The Decision Logic Table Technique PAM 310-11. Department of the Army (1967).

U.S. A.I.D. Desalination Manual. United States International Development Cooperation Agency, Office of Engineering, and CH2M Hill International Corp (1980).

Biblio-1

The proponent agency of this publication is the Office of the Chief of Engineers, United States Army. Users are invited to send comments and suggested improvements on DA Form 2028 (recommended Changes to Publications and Blank Forms) direct to HQDA (DAEN-ECE-G), WASH DC 20314-1000.

By Order of the Secretary of the Army:

Official:

R. L. DILWORTH
Brigadier General, United States Army
The Adjutant General

JOHN A. WICKHAM, JR.
General, United States Army
Chief of Staff

DISTRIBUTION:

To be distributed in accordance with DA Form 12-34B requirements for Water Supply-Special Projects.

***U.S. GOVERNMENT PRINTING OFFICE 1995-388-421/40468**

RECOMMENDED CHANGES TO EQUIPMENT TECHNICAL PUBLICATIONS



THEN... JOT DOWN THE DOPE ABOUT IT ON THIS FORM, CAREFULLY TEAR IT OUT, FOLD IT AND DROP IT IN THE MAIL!

SOMETHING WRONG WITH THIS PUBLICATION?

FROM: (PRINT YOUR UNIT'S COMPLETE ADDRESS)

DATE SENT

PUBLICATION NUMBER

PUBLICATION DATE

PUBLICATION TITLE

BE EXACT... PIN-POINT WHERE IT IS

IN THIS SPACE TELL WHAT IS WRONG AND WHAT SHOULD BE DONE ABOUT IT:

PAGE NO.	PARA-GRAPH	FIGURE NO.	TABLE NO.
----------	------------	------------	-----------

TEAR ALONG PERFORATED LINE

PRINTED NAME, GRADE OR TITLE, AND TELEPHONE NUMBER

SIGN HERE:

DA FORM 2028-2 JUL 79

PREVIOUS EDITIONS ARE OBSOLETE.

P.S.—IF YOUR OUTFIT WANTS TO KNOW ABOUT YOUR RECOMMENDATION MAKE A CARBON COPY OF THIS AND GIVE IT TO YOUR HEADQUARTERS.

PIN: 060240-000